

**CORPORATION OF THE CITY OF COURTENAY  
COUNCIL MEETING AGENDA**

**DATE:** February 19, 2018  
**PLACE:** City Hall Council Chambers  
**TIME:** 4:00 p.m.

---

**1.00 ADOPTION OF MINUTES**

- 1 1. Adopt February 5<sup>th</sup>, 2018 Regular Council meeting minutes

**2.00 INTRODUCTION OF LATE ITEMS**

**3.00 DELEGATIONS**

1. Maggie Hodge Kwan and Dr. Norman Carruthers, Comox Valley Community Foundation, 2018 Vital Signs Report
- 9 2. Jan Hesselting, Vice President, Affordable Housing Vancouver Island Society

**4.00 STAFF REPORTS/PRESENTATIONS**

**(a) CAO and Legislative Services**

1. Inspector Tim Walton – RCMP – General Duty Staffing Analysis – Resource Request

**(b) Engineering Services**

- 19 2. Subdivision and Development Servicing Bylaw; Presentation by Dan Huang, Urban Systems

**(c) Development Services**

- 25 3. Development Application Approval and Process Review
- 35 4. Development Permit with Variances No. 1731 – 191 Willemar Avenue (secondary residence and Environmental Development Permit)

**5.00 EXTERNAL REPORTS AND CORRESPONDENCE FOR INFORMATION**

**6.00 INTERNAL REPORTS AND CORRESPONDENCE FOR INFORMATION**

- 71 1. Briefing Note - Lewis Park – Tree Removal

**7.00 REPORTS/UPDATES FROM COUNCIL MEMBERS INCLUDING REPORTS FROM COMMITTEES**

**8.00 RESOLUTIONS OF COUNCIL**

**1. Mayor Jangula Finance Motion**

"WHEREAS,

1. The City of Courtenay's annual population increase has averaged 1.25% per year or just over 6% since 2013.
2. Canada's inflation rate for the same period averaged just under 1.5% annually and totalled 7.2% during the same period.
3. City of Courtenay single family property assessments have risen 22% in 2017 alone.
4. City of Courtenay 2017 operating expenses are budgeted to be \$48.6 Million. That represents a \$10.4 Million or 27.3% increase over 2013 actual operating expenses, leaving our taxpayers with similar increases.
5. Residential utility rates for water, sewer and garbage have increased by 25.5% and the water and sewer frontage tax has risen 350% since 2013.
6. Valley residents, including Courtenay taxpayers are facing major infrastructure projects for water, sewer and solid waste that are currently significantly underfunded and could well total over \$250M to complete.
7. Many residents of the city of Courtenay are pensioners who are on fixed incomes and will suffer undue hardships if taxes continue to increase at the rates of previous years.
8. Courtenay taxpayers are telling us that these tax increases are simply not sustainable.

Given the significant property assessment increases and higher interest rates, there is widespread uncertainty and concern throughout our community whether many will be able to manage or survive yet another sizable tax increase this year; and

THEREFORE BE IT RESOLVED THAT Council direct staff to implement the following measures:

1. An immediate tax freeze at current 2017 rates for 2018; and
2. Commission a City of Courtenay Core Services Review to provide guidance in reducing costs, identifying tax saving measures and improving efficiencies going forward.

**2. Councillor Hillian Supportive Housing Resolution**

WHEREAS supportive housing is a critical need in the Courtenay area and the Provincial Government has indicated willingness to provide funding contingent on the provision of City land; and

WHEREAS Council has been approached by the Homelessness Coalition stressing the urgency of both the housing need and of initiating an application for the limited available funding; and

WHEREAS the City has land that may be suitable for this purpose;

THEREFORE be it resolved that Council approve in principle the provision of City land for a supportive housing project and direct staff to initiate immediate discussion with BC Housing to facilitate the implementation of a supportive housing project at the earliest practicable date.

### **3. In Camera Meeting**

That notice is hereby given that a Special In-Camera meeting closed to the public will be held February 19<sup>th</sup>, 2018 at the conclusion of the Regular Council Meeting pursuant to the following sub-sections of the *Community Charter*:

- 90 1 (d) the security of the property of the municipality.

## **9.00 UNFINISHED BUSINESS**

## **10.00 NOTICE OF MOTION**

## **11.00 NEW BUSINESS**

## **12.00 BYLAWS**

### **For First, Second and Third Reading**

- 73 1. "Subdivision and Development Servicing Bylaw No. 2919, 2018"  
(A bylaw to regulate and require the provision of works and services in connection with the subdivision and development of land)

### **For Final Adoption**

- 231 1. "Zoning Amendment Bylaw No. 2870, 2017"  
(To rezone properties located on Cliffe Avenue near 29<sup>th</sup> Street)  
*Staff Note: This bylaw received third reading August 21, 2017 and was held in abeyance; final adoption contingent upon covenant (which was received).*
- 233 2. "Road Closure Bylaw No. 2876, 2017"  
(To close a portion of road near 29<sup>th</sup> Street and Cliffe Avenue)  
*Staff Note: This bylaw received third reading August 21, 2017 and was held in abeyance; final adoption contingent upon final adoption of zoning amendment Bylaw 2870, 2017.*

## **13.00 ADJOURNMENT**





**R3/2018 – February 05, 2018**

**Minutes of a Regular Council Meeting held in the City Hall Council Chambers, Courtenay B.C., on Monday, February 05, 2018 at 4:00 p.m.**

**Attending:**

**Mayor: L. V. Jangula**  
**Councillors: E. Eriksson**  
**D. Frisch**  
**R. Lennox**  
**M. Theos**  
**B. Wells**

**Staff:**

**D. Allen, CAO**  
**J. Ward, Director of Legislative and Corporate Services/Deputy CAO**  
**W. Sorichta, Manager of Corporate Administrative Services**  
**I. Buck, Director of Development Services**  
**T. Kushner, Director of Public Works Services**  
**D. Love, Senior Advisor Strategic Initiatives**  
**R. O’Grady, Director of Engineering Services**  
**B. Parschauer, Director of Financial Services**  
**A. Guillo, Manager of Communications**  
**Neil Borecky, Manager of IT**

**1.00 ADOPTION OF MINUTES**

**.01**  
**MINUTES**

Moved by Wells and seconded by Theos that the January 15<sup>th</sup>, 2018 Regular Council meeting minutes be adopted.  
**Carried**

Moved by Theos and seconded by Wells that the January 29<sup>th</sup>, 2018 Special Council meeting minutes be adopted.  
**Carried**

Moved by Frisch and seconded by Theos that the January 29<sup>th</sup>, 2018 Committee of the Whole meeting minutes be adopted.  
**Carried**

**2.00 ADOPTION OF LATE ITEMS**

**3.00 DELEGATIONS**

Kathleen Johnson, Comox Valley & District Branch ACA3, BC SPCA, made a presentation to Council regarding the PetSmart Charities Spay/Neuter Grant Programme.



**4.00 STAFF REPORTS/PRESENTATIONS**

**.01**  
SUGGESTED  
RESOLUTION UBCM  
2018 VIA AVICC:  
DRAFT COMMON  
ASSET MANAGEMENT  
POLICY  
1670-01

Moved by Wells and seconded by Lennox that based on the February 6<sup>th</sup>, 2018 staff report “Suggested Resolution UBCM 2018 via AVICC: Draft Common Asset Management Policy”, Council approve the following resolution.

Whereas, the purposes of a British Columbia municipality and regional district include providing for stewardship of the public assets of its community;

And Whereas, the powers, duties and functions of British Columbia municipal and regional district Chief Administrative Officers include:

- a) overall management of the operations of the local government;
- b) ensuring that the policies, programs and other directions of the council or board are implemented; and
- c) advising and informing the council or board on the operation and affairs of the local government.

Now Therefore be it Resolved THAT, the Association of Vancouver Island Coastal Communities supports sound Asset Management practices as the means to achieve local Sustainable Service Delivery;

THAT BC municipalities and regional districts, their respective CAOs and staffs would benefit from guidance to a common communications approach to enhance Asset Management Practices;

And THAT the AVICC recommends the Union of BC Municipalities Resolve to develop and implement such a common communications approach in partnership with the LGMA and Asset Management BC.

**Carried**

**.02**  
DEVELOPMENT  
VARIANCE PERMIT  
NO. 1710 – NEW SIGN  
(1350 ENGLAND  
AVENUE)  
3090-20-1710

Moved by Wells and seconded by Frisch that based on the February 5<sup>th</sup>, 2018 staff report “Development Variance Permit No. 1710 – New sign at 1350 England Avenue”, Council approve OPTION 1 and issue Development Variance Permit No. 1710.

**Carried**

**.03**  
TEMPORARY  
BUILDING FOR  
HABITAT FOR  
HUMANITY SITE -  
1330 LAKE TRAIL  
ROAD  
DPV00006

Moved by Frisch and seconded by Wells that based on the February 5<sup>th</sup>, 2018 staff report “Temporary building for Habitat for Humanity site – 1330 Lake Trail Road”, Council authorize a temporary building on the Habitat for Humanity building site for a period of approximately 2 years.

**Carried**

**R3/2018 – February 05, 2018**

**Councillor Lennox left Council Chambers at 4:36 p.m.**

**Councillor Lennox returned to Council Chambers and took her seat at 4:37 p.m.**

**.04** David Allen, CAO and Brian Parschauer, Director of Financial Services made a presentation to Council highlighting the 2018 – 2022 Water and Sewer Budget key considerations.  
2018 – 2022 WATER AND SEWER BUDGET HIGHLIGHTS PRESENTATION

**Mayor Jangula left Council Chambers at 4:59 p.m.; Acting Mayor Lennox took the chair  
Mayor Jangula returned to Council Chambers and took his seat at 5:06 p.m.**

**.05** Moved by Frisch and seconded by Wells that based on the February 5<sup>th</sup>, 2018 staff report “2018 – 2022 Water Fund Financial Plan”, Council approve the 2018 – 2022 Water Fund Financial Plan; and,  
2018 – 2022 WATER FUND FINANCIAL PLAN  
1705-20 / 1830-05 That any budget surplus funds be allocated to the Water Fund Asset Management Reserve.  
**Carried**

**.06** Moved by Frisch and seconded by Wells that based on the February 5<sup>th</sup>, 2018 staff report “2018–2022 Sewer Fund Financial Plan”, Council approve the 2018-2022 Sewer Fund Financial Plan; and,  
2018 – 2022 SEWER FUND FINANCIAL PLAN  
1705-20 / 1715-20 That any budget surplus funds be allocated to the Sewer Fund Asset Management Reserve.  
**Carried**

**The council meeting recessed at 5:31 p.m.**

**The meeting reconvened at 5:37 p.m.**

## **5.00 EXTERNAL REPORTS AND CORRESPONDENCE FOR INFORMATION**

**.01** Moved by Frisch and seconded by Wells that the correspondence dated January 07, 2018 from the Comox Valley Accessibility Committee regarding Ryan Road Hill Walkway and Crossing to North Island Hospital Comox Valley and North Island College, be received for information.  
CORRESPONDENCE COMOX VALLEY ACCESSIBILITY COMMITTEE (RYAN ROAD WALKWAY AND CROSSING)  
0360-01  
**Carried**

**.02** Moved by Wells and seconded by Frisch that the letter of appreciation dated January 09, 2018, from the Indigenous Women’s Sharing Society, be received for information.  
APPRECIATION LETTER INDIGENOUS WOMEN’S SHARING SOCIETY  
0220-05  
**Carried**

**6.00 INTERNAL REPORTS AND CORRESPONDENCE FOR INFORMATION**

**.01** Moved by Wells and seconded by Theos that the February 5<sup>th</sup>,  
2018 CITIZEN 2018 Briefing Note, “2018 Citizen Budget Consultation”, be received for  
BUDGET information.  
CONSULTATION **Carried**  
1705-20

**.02** Moved by Wells and seconded by Theos that the In Camera  
ROUTINE RELEASE OF Resolutions per for the period of July to December 2017 be received for  
IN CAMERA information.  
RESOLUTIONS **Carried**  
JULY – DEC. 2017  
0570-05

**.03** Moved by Wells and seconded by Lennox that the Heritage  
HERITAGE ADVISORY Advisory Commission meeting minutes for November 22, 2017 be  
COMMISSION received for information.  
MEETING MINUTES **Carried**  
0360-20

**7.00 REPORTS/UPDATES FROM COUNCIL MEMBERS INCLUDING REPORTS FROM COMMITTEES**

COUNCILLOR Councillor Eriksson reviewed his attendance at the following events:  
ERIKSSON

- Chamber of Commerce Awards
- Comox Valley Community Foundation, Community Enrichment Awards
- World Community Film Festival

COUNCILLOR Councillor Frisch reviewed his attendance at the following events:  
FRISCH

- Comox Valley Accessibility Committee meeting
- DCBIA meeting
- Complete Streets open house
- Indigenous Women Sharing Society & Comox Valley Multicultural Society grand opening

COUNCILLOR Councillor Lennox reviewed her attendance at the following events:  
LENNOX

- Comox Valley Art Gallery RETURN exhibition

COUNCILLOR Councillor Theos reviewed his attendance at the following events:  
THEOS

- CVRD Sewage Commission meeting
- CVRD Sport Commission meeting
- Vancouver Island Regional Library Board; appointed Director at Large

### **R3/2018 – February 05, 2018**

COUNCILLOR  
WELLS

Councillor Wells reviewed his attendance at the following events:

- 5<sup>th</sup> Street Complete Streets project open house
- CVRD water plant project open house
- Comox Valley Community Foundation, Community Enrichment Awards
- Chamber of Commerce Awards
- Rotary Whiskey Fest Fundraising event

MAYOR  
JANGULA

Mayor Jangula reviewed his attendance at the following events:

- Indigenous and Multi-Cultural Centre opening
- Evergreen Club Robbie Burns luncheon event
- Comox Valley Community Foundation, Community Enrichment Awards

### **8.00 RESOLUTIONS OF COUNCIL**

**.01** Moved by Frisch and seconded by Lennox that

COUNCILLOR HILLIAN  
RYAN ROAD  
SIDEWALK  
RESOLUTION

WHEREAS on 5<sup>th</sup> September 2017, Council passed the following resolution:

“THAT the City engage with the Ministry of Transportation & Infrastructure to engineer a safe crossing of Ryan Road between North Island College and Cowichan Avenue, and to enhance pedestrian, scooter and cycling safe access along Ryan Road between the North Island Highway and Lerwick Road”; and

WHEREAS Council representatives met with the Minister of Transportation and Ministry officials at UBCM on September 28<sup>th</sup>, 2017 and have not received further response from the Ministry;

THEREFORE BE IT RESOLVED that the City write to the Minister requesting that funding to engineer a safe crossing of Ryan Road between North Island College and Cowichan Avenue, and to enhance pedestrian, scooter and cycling safe access along Ryan Road between the North Island Highway (Highway 19-A) and Lerwick Road, be included in next month’s provincial budget.

BE IT FURTHER RESOLVED that Council seek a meeting with the MLA and the Ministry of Transportation & Infrastructure officials in support of this request.

**Carried**

## **R3/2018 – February 05, 2018**

**.02**  
IN CAMERA  
MEETING

Moved by Eriksson and seconded by Wells that a Special In-Camera meeting closed to the public will be held February 5<sup>th</sup>, 2018 at the conclusion of the Regular Council Meeting pursuant to the following subsections of the *Community Charter*:

- 90 (1) (e) the acquisition, disposition or expropriation of land or improvements, if the council considers that disclosure could reasonably be expected to harm the interests of the municipality;
- -90 (2) (b) the consideration of information received and held in confidence relating to negotiations between the municipality and a provincial government or the federal government or both, or between a provincial government or the federal government or both and a third party.

**Carried**

### **9.00 UNFINISHED BUSINESS**

**.01**  
JANUARY 15<sup>TH</sup>  
DELEGATION -  
KUMUGWE  
CULTURAL SOCIETY  
FUNDING REQUEST &  
POTLATCH 67-67  
BUDGET

Moved by Frisch and seconded by Lennox that Council postpone the funding request from Kumugwe Cultural Society and direct staff to provide a report investigating the costs and implications of providing a donation to Potlatch 67-67 including costs and options related to providing in kind support and report back to Council at the February 19<sup>th</sup>, 2018 meeting.

**Carried**

### **10.00 NOTICE OF MOTION**

### **11.00 NEW BUSINESS**

**.01**  
CVRD WATER  
VOTING STRUCTURE  
470-20

Moved by Wells and seconded by Theos that the letter from the Comox Valley Regional District be received and that the following distribution of weighted votes for City of Courtenay Directors on the Comox Valley Water Committee for 2018 be as follows:

|                            |                |
|----------------------------|----------------|
| <i>Mayor Jangula</i>       | <i>1 vote</i>  |
| <i>Councillor Theos</i>    | <i>2 votes</i> |
| <i>Councillor Wells</i>    | <i>2 votes</i> |
| <i>Councillor Eriksson</i> | <i>2 votes</i> |

**Carried**

### **12.00 BYLAWS**

**.01**  
“BYLAW NO. 2910,  
2017” (TO CHANGE  
COMMERCIAL TO  
URBAN RESIDENTIAL  
468 3RD STREET)

Moved by Frisch and seconded by Lennox that “Official Community Plan Amendment Bylaw No. 2910, 2017” pass third reading.

**Carried**

Moved by Wells and seconded by Frisch that “Official Community Plan Amendment Bylaw No. 2910, 2017” be finally adopted.

**Carried**

**R3/2018 – February 05, 2018**

**.02** Moved by Frisch and seconded by Lennox that “Zoning Bylaw No. 2911, 2017” pass third reading.  
**Carried**

(SECONDARY SUITE  
AT 468 3RD STREET) Moved by Frisch and seconded by Wells that “Zoning Amendment Bylaw No. 2911, 2017” be finally adopted.  
**Carried**

**13.00 ADJOURNMENT**

**.01** Moved by Lennox and seconded by Wells that the meeting now adjourn at 6:21 p.m.  
**Carried**

**CERTIFIED CORRECT**

---

**Director of Legislative and Corporate Services**

**Adopted this 19<sup>th</sup> day of February, 2018**

---

**Mayor**





# THE EDEN CONCEPT

**Good Housing for All Canadians  
A Successful European Business Model**

## **ROADMAP**

From overheated Housing and Rental Markets to reasonably priced Quality Rental Apartments for Canadian Families and Citizens

**Jan Hesseling**

# Housing Market in B.C. anno 2016

## Problem - Solution

### Some Facts

British Columbia has 4.6 million inhabitants.

The Greater Vancouver Area has more than 3.2 million residents.

The Greater Victoria Area has approx. 360,000 residents (estimated in 2016)

Approximately 52 % of the citizens of BC are living in privately owned houses and/or apartments.

The rest of the citizens depend on the rental market.

This large group of 2.2 million Canadians who are depending on the Rental Market is growing. **This group consists of young families, young citizens, students, a growing group of single parents, seniors, and all Canadians with a minimum or moderate income who cannot afford to buy a house of their own.**

The price of houses has steadily gone up over the last 15 years, so have the rents. For more details please visit the links of [Canada Mortgage and Housing Organization](#) at the end of this chapter. The price of housing and real estate, *and the Level of Rent, are dictated by the Market Mechanism of Supply and Demand.* The supply of both rental housing and real estate is low so the prices are high.

### Market Dynamics

Right now July 2016, the private housing market prices in Vancouver, Victoria and the rest of BC are going through the roof, thus making it *impossible for first-time house owners to enter the housing market. This group too is forced to continue to rent.*

The same trends follow the rental market keeping the demand side up and thus allowing for very high rents, and therefore severely financially limiting large numbers of Canadians especially those in the lower income brackets.

The *average* price for a 2 bedroom apartment in 2015 in BC (Source: Rental Market Report 2015) was \$ 1.200 per month and \$ 1.400 for a 3 bedroom apartment.

In Vancouver, we even see rents in the \$3000- \$5000 range for new 2 bedroom apartments.

**High rents force Canadians into scarcity and even poverty.**

A minimum income in BC based on a \$ 10.65 hourly rate, based on a full-time job, generates a monthly gross income of \$ 1,842.45 for a single person.

With a high rent, a hydro bill, internet, cell phone, and food it leaves no room for medical, clothing, paying off loans, education or recreation.

High rents make it impossible to pay back a student loan or to save for a down payment of a mortgage and severely limit this large group to spend money for their own well-being.

A substantial raise in minimum wage is not going to be expected anytime soon and is not going to make a difference in the housing situation, because it does not affect the supply side of the market.

This precarious financial and housing situation for a large group of Canadians is not going to change in a short term. The private sector is not planning to build a high enough number of apartments that will make a substantial difference. Band-Aid solutions, by building small numbers to patch up the most pressing housing situations are costly and only cosmetically adding to a solution.

To make a difference we need a **structural solution** on the supply side of the rental market.

**The Eden Concept can provide that Solution.**

Links Rental market reports and mortgages;

Canada Mortgage and Housing Organization (CMHC)  
<https://www.cmhc-schl.gc.ca/en/hoficlincl/homain/index.cfm> Rental market reports (available on this page)  
<https://www.cmhc-schl.gc.ca/en/hoficlincl/homain/foan/index.cfm>





## Solution

### The Eden Concept

The only effective way to change the rental market situation towards more reasonable rents is by **adding large numbers** of low-rent, quality apartments on the supply side of the market.

**The Eden Concept provides such an effective change**, which in turn provides *a structural change in the rental market* versus Band-Aid solutions.

This approach will affect the overheated rent levels of the existing apartments and houses in the market towards a lower and more reasonable level of rent. **It will also enable low-income residents to live in a comfortable home and spend more on the wellbeing of themselves and/or their families.**

*Executing an Eden Project will add a large number of rental apartments to the market.*

The numbers will be in the thousands, depending on the size of the rental need of that area.

Executing The Eden Concept will also have an effect on the private housing market

As larger numbers of reasonable priced, quality apartments appear on the rental market, **the housing market will cool.**

## The Eden Concept is based on two principles

The lean and effective Organization that is going to execute the Solution is a **Non-Profit Organization for Rental Apartments**.

The Organization has a number of goals.

The first goal of the Organization is to add a large enough number of **reasonably priced quality rental apartments** to the rental market in order to make a difference. The rents will be around 60 % of the actual market rents in 2016.

The concept would allow low-income families and citizens, to rent a quality apartment and still be able to spend money on the wellbeing of their families and themselves.

*The net gains of the Rental Organization will be used to pay off the initial investment.*

*Once paid off within 10 – 15 years, it now can expand its operations and double its capacity building more apartments and **expanding to other cities in BC, thus improving our Canadian Society.***

**The Organization is designed to be a Self-Propelling not for Profit Rental Apartment Building Machine.**

*The Organization is **designed to be Financially Independent and Self-supporting.***

*It is not depending on charity or donations, but will **generate Wealth by itself** using a lean professional management structure to facilitate operations and an effective business model.*



## Eden Concept and the Local Economy

Applying The Eden Concept will boost local economies, as they will be involved in the building projects and later in the project providing long-term quality jobs in maintenance and property management of the rental apartments

## How can it afford to ask lower rents and still double its operations?

### A Number's Game

Economical principle; Larger numbers reduce costs per unit.

The construction costs drop when the numbers go up.

Building a single rental house is relatively expensive. There is a list of costs involved, like costs for designing, permits, building lot, construction, and maintenance and rental management, etc.

When building **30** two bedroom apartments, estimated average building cost per unit are around \$ 200.000.

Upscaling it to a number of **300** of the same apartments will drop the average price to \$ 150.000 per unit. Building a number of **3000** of the same apartments will again drop the building costs to less than \$ 100.000 per unit. Reducing costs is a *Number's Game*.

Building in larger numbers will not only drop the *constructing costs* per unit, acquiring larger *Building Lots* will drop the costs per lot with a similar percentage per unit too.

Also, the *Property Management Costs* per unit will dramatically drop too. Property management becomes profitable with a minimum of 200 units, using best practices for good property management to adequately handle any rental challenge.

*The large number Eden approach will roughly split the total costs per unit in half.*

**This allows the NonProfit rental Organization to drop their rents to an affordable level and still make money to pay back the initial investment within 10- 15 years.**

Building a **larger quantity** will also **boost the Return On Investment (ROI)** which will allow for paying back the initial investment in a **shorter** period of time (**Amortization**).

## Why Quality Apartments

The principle of building quality apartments to a standard of allowing at least 50 years of residence without enormous replacement costs brings down the overall- and long-term costs of property management. It allows for a longer period of collecting rents and a higher return on investment.

It reduces the operation costs.

High standards of building

- Using quality building materials improves the longevity of the structure
- Improves the appreciation of the residents
- Reduces the environmental impact in the long run
- Improves sound Insulation, to improve quality of residing
- Using temperature Insulation to reduce heating costs and environmental impact.

## A Successful Business Model

The NPO for Rental Apartments not only builds affordable housing but also incorporates another real estate into their plans. They would include a percentage of the rental apartments to rent out at a regular market rate. Since they are involved in building a large area with residential buildings, it makes sense to incorporate building a shopping mall, workshops, garages and any other service buildings a neighbourhood needs to make it attractive to future residents.

The NPO would rent these units out at a regular market rate, thus ensuring their financial independence and generating more income for their main objective; Building more quality affordable homes.

**This proven successful business model provides financial independence.**

**No charity or gifts needed to keep these NPO's going**

Executing this proven business model frees NPO's from the need for charity and gifts or fundraising to keep their housing projects going.

**Our Canadian citizens deserve better** than being dependent on those initiatives that will never provide enough support in a sufficient quantity.

## The Eden Concept

### A Proven Concept in many European countries

Facing similar challenges for housing their populations, different European countries came up with **effective solutions**. Especially in Western Europe, we see The Eden principles applied successfully. This concept has been used successfully in The Netherlands for the last 100 years. The first one started in Amsterdam in 1914.

In every city above 10,000 inhabitants, you will find one or more Non-Profit rental apartment Organizations providing affordable quality rental homes for the citizens. This concept allows people in the lower income brackets to spend less on rent and leaves them a bigger *budget to support* themselves and their families.

## Some Facts about this successful business model in The Netherlands

- More than 30% of all the 7.5 million houses/apartments in The Netherlands (population 17 million inhabitants) is owned and managed by NPO's providing quality homes at an affordable rent.
- The average basic rent per unit is 472 euros.
- These NPO's are providing quality jobs. Number of FTE's in 2013 26,264
- Almost 400 of these thriving NPO's in the Netherlands together own more than 2.5 million units.
- Their total equity is exceeding 142 billion euros.





**Executing this working business model on a large scale in Canada can change the Canadian housing landscape significantly for the better.** It can provide quality homes for all the Canadian families and other residents who are struggling to make ends meet, due to sky-high rents. Executing this successful business model allows for adding significant numbers to the rental market and help Canada become a **great place to live for *all* their citizens, it will make a difference.**

*For more information contact:*

*Jan Hesseling*

*September 17<sup>th</sup>, 2016. Courtenay, BC, Canada*

*Business Consultant - Management Coach*

● *Hesseling & Partners*

*Head Office*

*6481 Tsolum River Road*

*Courtenay BC V9J 1P1*

*Website [www.HesselingHR.com](http://www.HesselingHR.com) [janhesseling@telus.net](mailto:janhesseling@telus.net) Cell 1.250.650.5004*

*Examples Dutch NonProfit Organizations for Rental Apartments, websites:*

[www.stadgenoot.nl](http://www.stadgenoot.nl) *Amsterdam, click the English version on the right side drop down menu.*

[www.patrimonium-groningen.nl](http://www.patrimonium-groningen.nl)

[www.eigenhaard.nl](http://www.eigenhaard.nl)





THE CORPORATION OF THE CITY OF COURTENAY

## STAFF REPORT

---

**To:** Council

**File No.:** 5220-02

**From:** Chief Administrative Officer

**Date:** February 19, 2018

**Subject:** Subdivision and Development Servicing Bylaw

---

### **PURPOSE:**

The purpose of this report is for Council to consider adoption of the Subdivision and Development Servicing Bylaw No. 2919, 2018.

### **POLICY ANALYSIS:**

Section 506 of the *Local Government Act* allows Council to adopt a bylaw that provides the minimum requirements for works and services in respect of the subdivision on land.

### **EXECUTIVE SUMMARY:**

Since 2016, the City has undertaken a major review and update of the existing Subdivision Control Bylaw and associated engineering specifications that are almost 30 years old. This has involved consultation with members of the development community, industry experts, and City staff at multiple points throughout the update. The comprehensive update modernizes the bylaw to meet current community needs, through updated engineering design guidelines, construction specifications and detailed drawings.

### **CAO RECOMMENDATIONS:**

THAT based on the February 19, 2018 staff report "Subdivision and Development Servicing Bylaw" Council approve OPTION 1 and proceed to first, second and third readings of "Subdivision and Development Servicing Bylaw No. 2919, 2018".

Respectfully submitted,

David Allen, BES, CLGEM, SCLGM  
Chief Administrative Officer

### **BACKGROUND:**

In 2016, the City of Courtenay commissioned Urban Systems Limited to undertake a major review and update to the current Subdivision Development Servicing (SDS) Bylaw that is almost 30 years old. This bylaw regulates the subdivision and development of land within the City of Courtenay and requires the provision of infrastructure works and services to a prescribed standard. The update of the bylaw aligns with

Council's interest in reviewing the current development process and increasing the efficiency and effectiveness of the process.

In general, the works and services that are required as part of the development of land may include, but are not limited to, the following:

- Utilities (water, storm, and sanitary sewer systems, and stormwater management facilities);
- Roadways, curb and gutter and sidewalks;
- Street lighting; and,
- Landscaping.

This comprehensive update modernizes the bylaw to meet current community needs, through updated engineering design guidelines, construction specifications and detailed drawings. The updated engineering design guidelines, construction specifications and detailed drawings are based on the Master Municipal Construction Document (MMCD) Platinum Edition, 2009, and include appropriate supplementary clauses to suit the City's requirements.

This Staff Report outlines the process to review and update the SDS Bylaw, including the coordination with stakeholders, development community and the public throughout the entirety of the process.

#### **DISCUSSION:**

The objectives of the Subdivision and Development Servicing (SDS) Bylaw update are to:

- Provide common expectations and requirements for all new developments in the City
- Identify base requirements for infrastructure to be provided with new development
- Formalize the current infrastructure practices of the City

The SDS Bylaw update increases fairness and transparency in the development process by clearly articulating the design and construction specifications for new infrastructure.

Council was first introduced to the SDS Bylaw update in April of 2016. Following that, the City of Courtenay hosted an Open House and stakeholder engagement session to solicit feedback from the development community and other specific stakeholders. A series of staff workshops were conducted through the remainder of 2016 and early 2017 to review, in detail, the design criteria, drawings standards, and the front-end components of the SDS Bylaw. A legal review of the bylaw was conducted in early 2017.

The Final Draft of the SDS Bylaw, Design Criteria and Supplemental Specifications was completed in November 2017. The Final Draft was circulated again to the development community, specific stakeholders, and posted on the City's website with final comments received by the City up until January 5, 2018.

Based on the most recent feedback, there were a few minor updates to the Final Draft which have been incorporated. Therefore, the City of Courtenay Subdivision and Development Services Bylaw, along with

associated design criteria and supplemental design standards, is being presented to Council for bylaw consideration and is attached to this Staff Report.

**FINANCIAL IMPLICATIONS:**

There are no direct financial implications related to adopting the Subdivision and Development Servicing Bylaw.

**ADMINISTRATIVE IMPLICATIONS:**

The updating of the Subdivision and Development Servicing bylaw is within the 2018 corporate work plan.

**ASSET MANAGEMENT IMPLICATIONS:**

The updating of the Subdivision and Development Servicing bylaw will provide the development community with an updated standard for the installation of infrastructure that the City will take over upon completion of the subdivision construction. The updated bylaw updates the previous standards and advances the design and construction practices to incorporate best practices for today, providing infrastructure that will have the lowest total lifecycle cost.

**STRATEGIC PRIORITIES REFERENCE:**

**We proactively plan and invest in our natural and built environment**

- Continued focus on asset management for sustainable service delivery

**We focus on organizational and governance excellence**

- We support meeting the fundamental corporate and statutory obligations
- We recognize staff capacity is a finite resource



- **Area of Control**  
The policy, works and programming matters that fall within Council’s jurisdictional authority to act.
- ▲ **Area of Influence**  
Matters that fall within shared or agreed jurisdiction between Council and another government or party.
- **Area of Concern**  
Matters of interest outside Council’s jurisdictional authority to act.

**OFFICIAL COMMUNITY PLAN REFERENCE:**

The Subdivision and Development Servicing standards reflect the policies contained within the Official Community Plan.

**REGIONAL GROWTH STRATEGY REFERENCE:**

Not referenced

**CITIZEN/PUBLIC ENGAGEMENT:**

Staff consulted with members of the development community and other specific stakeholders based on the IAP2 Spectrum of Public Participation:

[http://c.ymcdn.com/sites/www.iap2.org/resource/resmgr/imported/IAP2%20Spectrum\\_vertical.pdf](http://c.ymcdn.com/sites/www.iap2.org/resource/resmgr/imported/IAP2%20Spectrum_vertical.pdf)

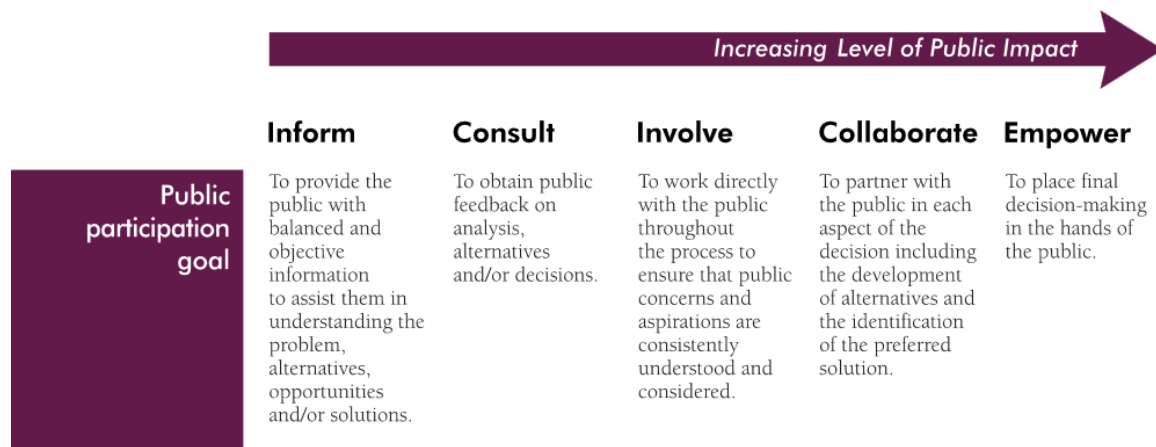

**OPTIONS:**

- Option 1: THAT based on the February 19, 2018 staff report 'Subdivision and Development Servicing Bylaw' Council approve OPTION 1 and proceed to first, second and third readings of "Subdivision and Development Servicing Bylaw No. 2919".
- Option 2: THAT Council refer the Staff Report back to staff for additional modification.

Prepared by:



Craig Perry, P.Eng.  
Manager of Engineering Projects



Ryan O'Grady, P.Ag., P.Eng.  
Director of Engineering Services







THE CORPORATION OF THE CITY OF COURTENAY

## STAFF REPORT

---

**To:** Council  
**From:** Chief Administrative Officer  
**Subject:** Development Application Approval and Process Review

**File No.:** 3030-00-1801  
**Date:** February 19, 2018

---

### ISSUE:

The development sector has a number of concerns about the development process at the City of Courtenay, and the impact that this is having on the time and effort required to process various development applications. The perception is that the City takes significantly more time than other municipalities in processing and approving development applications and that the City is not “Open for Business”.

The goal of the development sector is to reduce risk, cost (i.e. time is money), maximize profit, and move on to the next development.

City Council provides direction to Staff by approving the City’s bylaws and policies (i.e. OCP, Zoning, Subdivision and Development, etc.).

City staff are responsible for ensuring that all new development conforms with Provincial laws and regulations, the City’s bylaws, policies, and procedures. Once a new development is approved and constructed, the City is responsible for operating, maintaining, renewing, and eventually replacing all the infrastructure necessary to support the new development in perpetuity. Roads, sidewalks and trails, water, sewer, street lights are but a few examples.

One of the goals of the City is “Sustainable Service Delivery”, which relies on sound City-owned infrastructure and assets to provide services to City residents in a cost effective manner. Ensuring that new development is of a quality that supports this goal is reflected in the development approval process.

Having greater clarity about how to better align these two goals is the focus of this staff report.

### PURPOSE:

The purpose of this report is to provide Council with information on recent development application approval times at the City of Courtenay, outline options for a development process review group, and to seek direction to prepare terms of reference for this group.

### CAO RECOMMENDATIONS:

That based on the February 19<sup>th</sup> 2018 staff report “Development Application Approval and Process Review”, Council approve OPTION 1 and direct staff to prepare a terms of reference for a development review working group consisting of 3 development representatives, 3 City staff and 2 elected officials.

Respectfully submitted,

David Allen, BES, CLGEM, SCLGM  
Chief Administrative Officer

**BACKGROUND:**

At the December 4, 2017 Council meeting and again at the February 5, 2018 Committee of the Whole meeting Council discussed resolutions pertaining to processing times for development applications. The preamble to the December 4<sup>th</sup> resolution also included commentary on affordable housing. The general theme of the subsequent discussions at the two Council meetings was to find ways to enhance dialogue between the City and the development industry to resolve stumbling blocks in the application review process and further expedite development approvals.

**DISCUSSION:**

While City staff understands the important role the City plays in the development industry, it is also recognised the primary role of staff is to uphold the public interest and work in the best interest of the City tax payer. This role is a fine balance that takes into consideration many factors including the desires of the greater community, the impacts of development on immediate neighbourhoods and the environment, the capacity of existing infrastructure, the maintenance burden of new infrastructure, the safety of future occupants and the interests of developers. Achieving this balance can be challenging to navigate. For example, at times applications consistent with broad community goals conflict with the concerns of local neighbourhoods. The goals of a developer may not meet the desire of the community. Or proposals consistent with community goals will be challenged by the capacity of City infrastructure.

The role of staff is to assist applicants and the public understand and navigate these issues and ultimately make recommendations to Council. City staff take great pride in their work, do a professional job, and have shown significant resilience in the face of workload pressures caused by increased development activity and greater public responsibility and accountability.

To do their jobs effectively staff rely on numerous sources including policy documents, bylaws, legislation, and best practice. While the data below shows the City is generally doing a good job at efficiently processing applications, further policy/bylaw development and partnerships could lead to shorter approval times.

**Current Approval Times**

The following charts illustrate the processing times for zoning amendments, development permit approvals, subdivision approval and single family building permit issuance over the last 2 years. In general these times are consistent with BC municipal averages. To date staff has spoken to 3 communities about their current timelines which are outlined in the table below. None of those communities have the development application tracking data readily available that Courtenay has so “best guesses” of average applications were provided. Further comparisons can be obtained if requested.

**Approximate Development Approval Times**

| Community      | Rezoning  | DP         | Subdivision – PLR | Single Family Building Permit |
|----------------|---|------------|-------------------|-------------------------------|
| Courtenay      | 4-5 months  | 2.8 months | 8 weeks           | 2 weeks                       |
| Campbell River | 3-4 months  | 3.5 months | 8 weeks           | 2-3 weeks                     |
| Colwood        | 6-8 months  | 3-5 months | 6 weeks           | 2 weeks                       |
| Lake Country   | 4 months to 1 <sup>st</sup> and 2 <sup>nd</sup> reading | 3 months   | 12 weeks          | 2 weeks                       |

### Zoning Amendment Applications

The chart below illustrates the processing times for rezoning applications over the last two years. The blue bars show the time from application submission to third reading of a bylaw and the red bars indicate the time from application to adoption. The difference between third reading and adoption for more complex applications is related to the required legal documentation that must be prepared, executed and registered on title prior to final bylaw adoption. In many instances this timeline is not within the City's control. For example, application 1701 was given third reading on August 21, 2017 and the covenant was prepared and agreed to by the applicant on September 27, 2017. However, the signed copy of the covenant was only returned to the City in late January 2018 adding 4 months to the processing time. During this 4 month time period staff had contacted the applicant a number of times to ensure there were no concerns.

The City's rezoning application form advises that complex applications can take 12 months or longer to process. With the exception of the 4 month delay by the applicant noted above, none of the applications in the last 2 years took over 12 months. **The average processing time to 3<sup>rd</sup> reading was 127 days (4.2 months) and 145 days to adoption (4.8 months).**

With regard to affordable housing projects, guidelines that were available at a recent Affordable Housing Workshop in Courtenay advise that if Local Government is a full partner rezoning will typically take 1-6 months and development permits will take 7-12 months. Guidelines provided by the BC Non-Profit Housing Association advise prospective housing providers to anticipate between 4 and 12 months for municipal approvals depending on if rezoning or OCP amendments are required.

Although the City was not a full partner, the Habitat for Humanity rezoning (1705) on Lake Trail Road took under 6 months to complete and the development permit (1724) was issued with a variance in just over 2 months.

The only other affordable housing project in recent years is the Braidwood Housing project which is on a property already zoned for the use so rezoning was not required. The development permit (1702) with variances for this project was issued in 4.5 months including revised plans submitted midway through the review process.

Both of these applications fit within the typical affordable housing approval timelines referenced above.

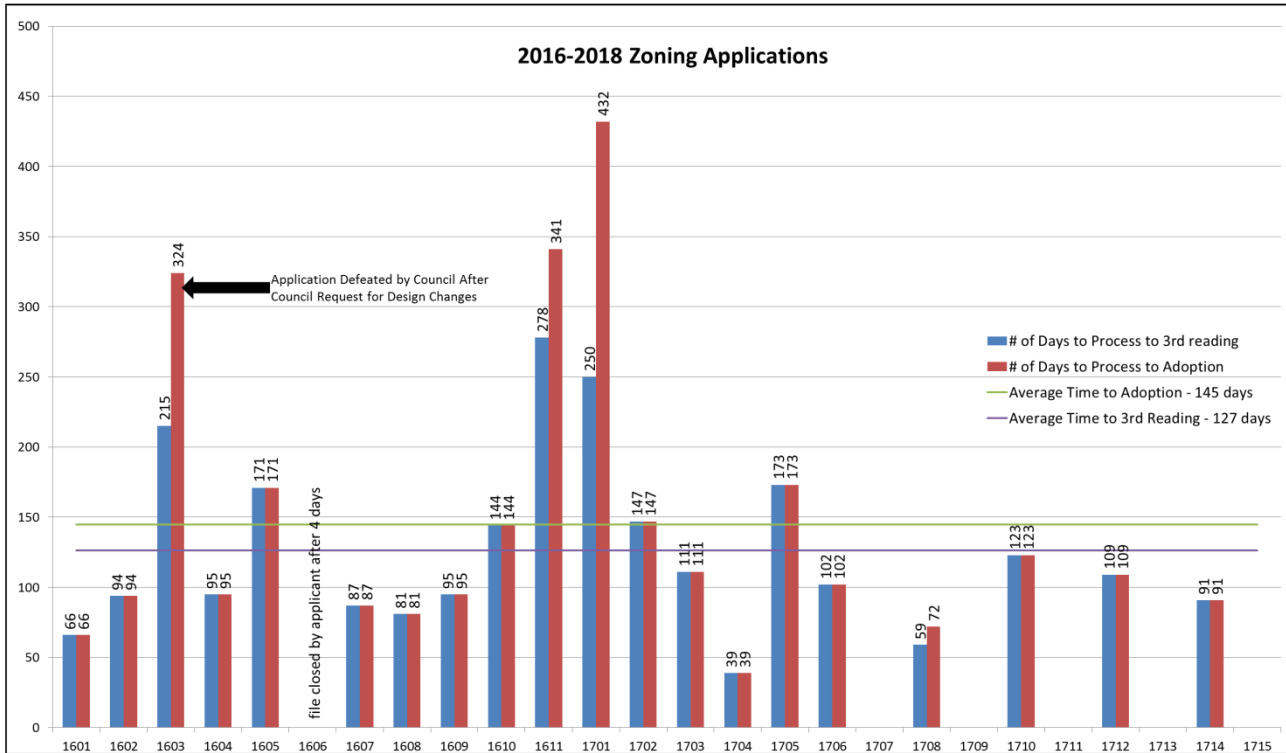

Development Permit Applications

Development Permits are required to assess the form and character for many projects prior to building permit application. **The average processing time for a development permit between 2016 and 2018 was 84 days.** Applications that take longer to review and process are typically more complex proposals and often involve some iteration in design through the process. Over the last 2 years almost all applications were processed in less than 5 months (150 days). The most significant anomaly is application 1612. This file was associated to a project that included a zoning amendment (1603 in the zoning chart) that was defeated by Council. In this instance the Development Permit application fee was refunded and the file was closed. If this application is removed from the calculation, average processing time is reduced by a week.

All Development Permit approvals have been delegated to the Director of Development Services which helps expedite the process. However, applications that include variances are required to be considered by Council which can add 3 to 4 weeks to the process. This extra time is associated with neighbourhood consultation, statutory advertising and Council meeting schedules.

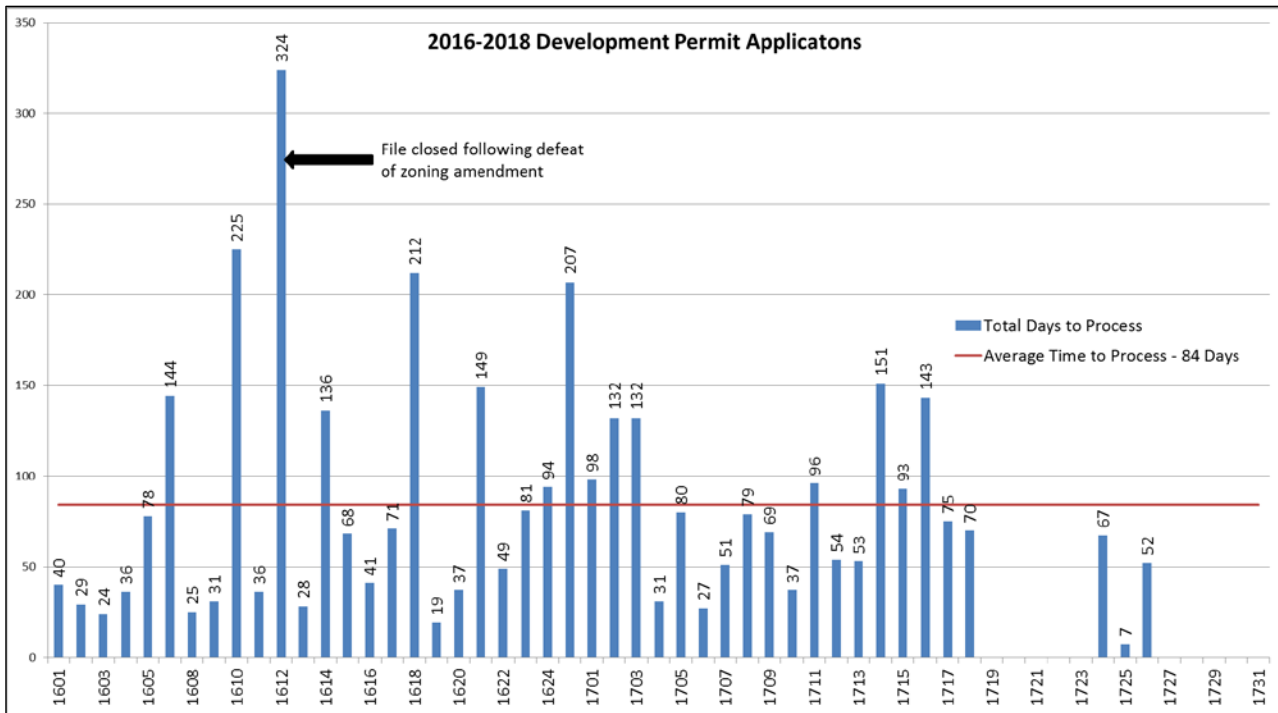

Subdivisions

While all application types are impacted by applicant response times to requests for further information (e.g. revised drawings, studies, covenant review and signature) the subdivision review and approval process is especially influenced by the applicant because the process includes time to prepare construction drawings and then build the subdivision infrastructure. Accordingly, the table below outlines the time applications are in the City’s hands and the time that it is in the applicant’s hands. This is not to say the City can’t find ways to reduce the work of the applicant or add further clarity to the process, but it does provide context for the processing timelines. It is anticipated the timelines for review of construction drawings associated with all development applications will be significant topic of discussion with the development sector going forward.

**In this regard, it is recognised that much of the delay that exists in application processing can be attributed to dated, non-existent or unclear policies and bylaws.** Most notably, the City’s Subdivision and Development Servicing Bylaw is 33 years old. This bylaw and the associated specifications and standards is critical in providing guidance and clarity, to both city staff and developers, on the standards required for the design of civil infrastructure. In the absence of this bylaw, current development approval staff have been cautious to ensure that infrastructure accepted will meet the operations and maintenance requirements of the City and not unduly burden the taxpayer. It is acknowledged that this extra care has increased review times in some instances. **Of significance, the Subdivision and Development Servicing bylaw has just been updated and is before Council for consideration at the February 19, 2018 Council meeting.** Following adoption it is anticipated this bylaw will lead to better clarity and quicker review times.

Another positive change is the re-instatement of one of the Engineering Technologist positions that was previously part of the Engineering Services development review team. Prior to the transfer of the Subdivision and Development Servicing function from the Engineering Department to the Development Services Department in late 2015, the team included an Engineer/Approving Officer and two Technologists. One Technologist was dedicated to the subdivision process and the other reviewed and responded to Planning and Building applications. When the function was transferred it was staffed by an Engineer/Approving Officer and one Technologist position. Re-hiring for this position was included in the positions approved by Council last year and the incumbent starts work with the City on February 19, 2018. Following a period of orientation and training it is anticipated the workload burden and stress on current staff be reduced leading to quicker processing times.

**Affordable Housing**

The vast majority of subdivision applications in the City are for suburban style single family lots, that will not resolve the affordable housing issues outlined at the December 4<sup>th</sup> Council meeting. Staff believes there are opportunities to improve the processing times associated with single family subdivisions, however, to ensure a greater impact on increasing the number of affordable housing units in Courtenay, Council may wish to direct staff to prioritize infill and multi-family development applications over the development of single family lots.

That said, it is recognised that single family housing is still in high demand and the construction industry associated with single family homes is a significant local economic sector.

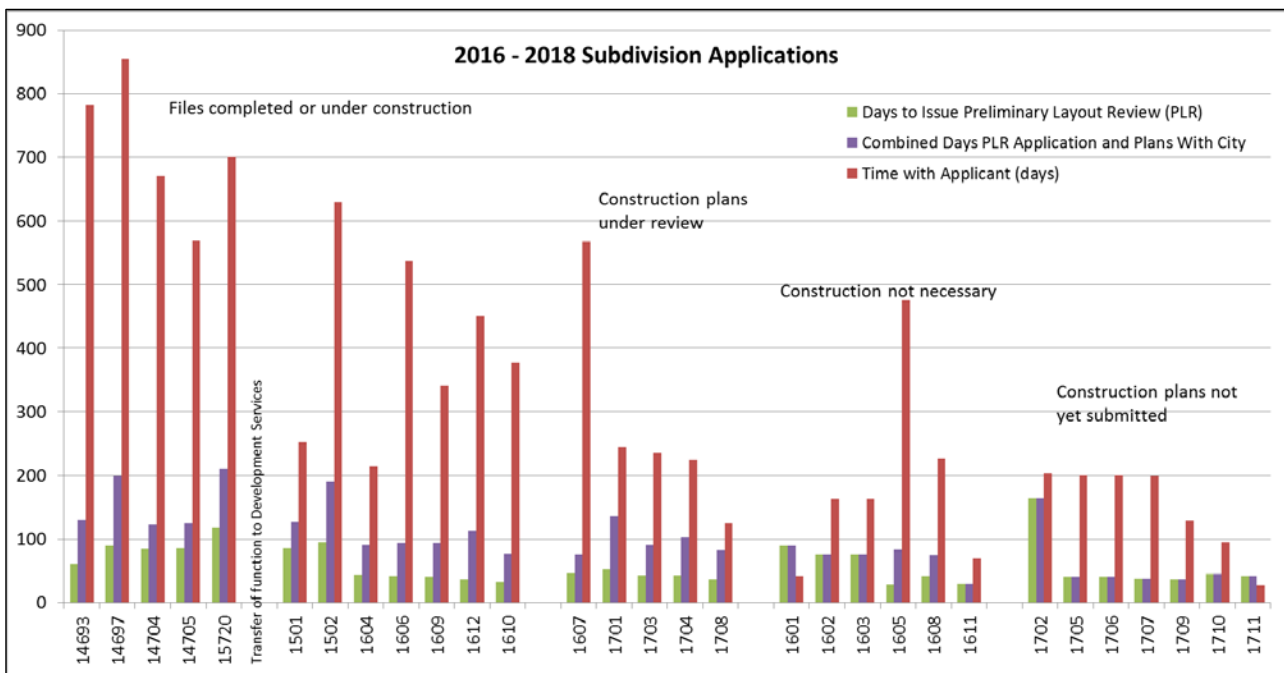

The charts above show the City is performing within commonly accepted municipal approval timelines.

Staff anticipate significant improvements will result from the adoption of the new Subdivision and Development Servicing Bylaw, the addition of an Engineering Technologist, and working with the development industry to understand their concerns, add clarity to the development process and improve the quality of submissions to the City.

**Working Group Options**

There are many examples of development process review committees from other communities. These vary from staff meetings with the Urban Development Institute in Lake Country to lunch meetings with the development association in Langford that are attended by city staff and councillors, or the more formal Council committees that include a broad membership of developers, public, staff and Council representation in Penticton and Campbell River.

Following discussion with representatives of the Development and Construction Association staff recommend that an initial working group be set up that would include three Comox Valley Development and Construction Association (CVDCA) representatives, three City staff from Development Services, and two Councillors.

The intent of this group would be to discuss process issues raised by both the development industry and City staff and find ways to improve them. To this end, the Development and Construction Association has sought feedback from its membership to identify a list of topics and the Director of Development Services has asked City staff to identify topics of concern to the City. A mutual list of topics would be put forward to the group to discuss and identify reasonable approaches to modify processes. At this time City staff have distilled the comments received to the following themes.

From the CVDCA:

- Add clarity to bylaws and policies based on reasonable standards
- Proactively engage with the development sector on where they see the need for process improvements
- Add clarity and consistency to requests for studies
- Empower City staff in decision making
- Council leadership in the face of neighbourhood opposition

From City Staff:

- Proactively engage with City staff on concerns with development review requirements
- Ensure complete applications are submitted
- Design submissions based on City policies and studies
- Applicants follow recommendations of their consultants
- Empower CVDCA representatives to make decisions on behalf of their membership

While there may be discussion of individual development applications to illustrate problems or why there are delays, the group would not be a venue to formally review applications.

The general mandate of this group would be to make recommendations regarding all aspects of land development including: Development application processes; City policies, procedures and bylaws that affect development such as application fees, servicing standards, and other land use and building regulations; and other matters of mutual interest. Critical to the success of this group will be a cross section of industry representation in the membership and positive, solution oriented discussion and compromise.

#### **FINANCIAL IMPLICATIONS:**

There are no direct financial implications with the preparation of this report. If a committee or working group is formed there will be minimal administrative costs that can be absorbed within the Development Services budget.

#### **ADMINISTRATIVE IMPLICATIONS:**

Research and preparation of this report took approximately 21 hours of staff time. If a committee or working group is formed there is likely to be direct short term impacts on application processing times as senior Development Services staff time is redirected attend meetings and to prepare and roll out any policy changes that result.

**ASSET MANAGEMENT IMPLICATIONS:**

Within the Asset Management Framework the Development Services Department is responsible for the approval of new City assets through the development approval process. It is critical that this is done with care and attention to ensure infrastructure is safe, reliable and does not unduly burden the City tax payer.

**STRATEGIC PRIORITIES REFERENCE:**

This report and any subsequent involvement in development process reviews align with the strategic priority “We focus on organizational and governance excellence”.

**We focus on organizational and governance excellence**

- We support and encourage initiatives to improve efficiencies
- We support meeting the fundamental corporate and statutory obligations
- We recognize staff capacity is a finite resource
- Communication with our community is a priority, and is considered in all decisions we make
- We responsibly provide services at a level which the people we serve are willing to pay

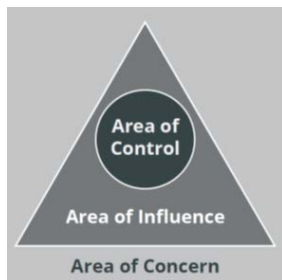

- **Area of Control**  
The policy, works and programming matters that fall within Council’s jurisdictional authority to act.
- ▲ **Area of Influence**  
Matters that fall within shared or agreed jurisdiction between Council and another government or party.
- **Area of Concern**  
Matters of interest outside Council’s jurisdictional authority to act.

**OFFICIAL COMMUNITY PLAN REFERENCE:**

There is no direct reference to the OCP.

**REGIONAL GROWTH STRATEGY REFERENCE:**

There is no direct reference to the RGS.

**CITIZEN/PUBLIC ENGAGEMENT:**

Staff would **inform** the public based on the IAP2 Spectrum of Public Participation:

[http://c.ymcdn.com/sites/www.iap2.org/resource/resmgr/imported/IAP2%20Spectrum\\_vertical.pdf](http://c.ymcdn.com/sites/www.iap2.org/resource/resmgr/imported/IAP2%20Spectrum_vertical.pdf)



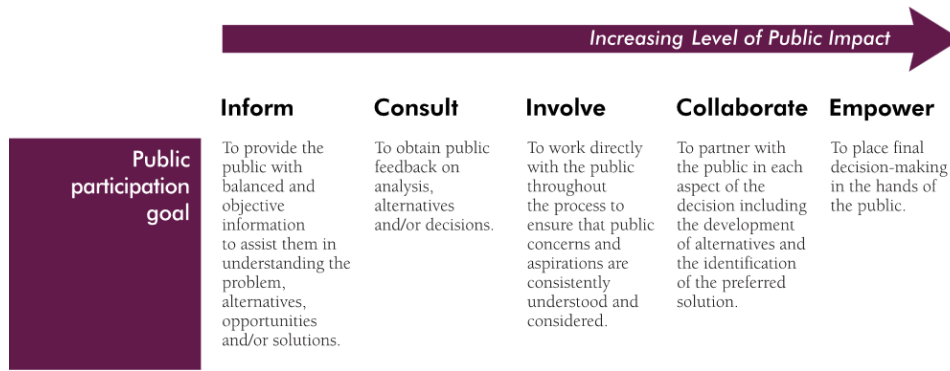

**OPTIONS:**

- OPTION 1: Council approve OPTION 1 and direct staff to prepare terms of reference for a development review working group consisting of 3 development representatives, 3 City staff and 2 elected officials.
- OPTION 2: Direct staff to prepare terms of reference for a Council committee to review development processes that includes public participation.
- OPTION 3: Accept the report for information and do nothing.

Prepared by:

---

Ian Buck, MCIP, RPP  
 Director of Development Services





## STAFF REPORT

**To:** Council

**File No.:** 3060-20-1731

**From:** Chief Administrative Officer

**Date:** February 19, 2018

**Subject: Development Permit with Variances No. 1731 – 191 Willemar Avenue (secondary residence and Environmental Development Permit)**

### PURPOSE:

The purpose of this report is for Council to consider a Development Permit with Variances to allow the construction of a detached secondary dwelling unit at 191 Willemar Avenue with a variance to the required minimum side yard setback adjacent a road.

### CAO RECOMMENDATIONS:

That based on the February 19, 2018 staff report “Development Permit with Variances No. 1731 – 191 Willemar Avenue (Secondary residence with Environmental Development Permit)”, Council approve OPTION 1 and proceed with issuing Development Permit with Variances No. 1731.

Respectfully submitted,

David Allen, BES, CLGEM, SCLGM  
Chief Administrative Officer

### BACKGROUND:

The subject property is an approximately 1122m<sup>2</sup> residential lot located at the intersection of Willemar Avenue and 2<sup>nd</sup> Street in West Courtenay, legally described as Lot D, Section 79, Comox District, Plan 18822 (Figure 1). The property is currently developed with a one-storey single residential dwelling and is located adjacent to Morrison Creek.

The applicant applied for rezoning to permit the detached secondary residence (granny flat) on the property last year. Council approved the rezoning application at the December 4<sup>th</sup> Council meeting. Construction of a secondary dwelling unit is subject to the development guidelines in the Official Community Plan (OCP) to ensure the form and character of the building is consistent with the existing neighbourhood and to protect the natural environment.



Figure 1: Location Map. Property shown in yellow. Morrison Creek shown in blue-green.

The applicant is requesting a reduced side yard setback in order to make the project feasible. An Environmental Development Permit is also required as all properties within 30m of a watercourse within the City are subject to the Development Permit Guidelines in the *Official Community Plan (OCP)*.

The applicant wishes to create a detached secondary residence for a family member, and recognizes the value the unit could provide to the general rental housing stock.

**DISCUSSION:**

**OCP Secondary Residential Development Permit Guidelines**

The form and character guidelines are in place in order to ensure that detached secondary residences integrate well with the existing property and contribute positively to the immediate neighbourhood.

The proposed secondary dwelling unit is a one storey, bachelor flat (open air) style residence of 47.5m<sup>2</sup> floor area located within the rear yard and side yard adjoining 2<sup>nd</sup> Street. Floorplans, elevation drawings, landscaping plan and full colour renderings of the proposed dwelling are available in the draft permit attached to this report (**Attachment No. 2.**)

The secondary dwelling layout and orientation as well as existing and proposed fencing have been designed to maximize privacy to the existing residence, the street and neighbouring properties. The secondary dwelling doors, window locations, and private open space have also been designed as privacy considerations. The front door faces 2<sup>nd</sup> Street, is covered and recessed from the building face. An additional door is provided facing the creek, and provides access to personal open space.

Architectural design features include partially vaulted rooflines with varying roof heights that step down towards the street, as well as high quality façade cladding: hardiplank, cedar gutter flashing, corner boards, window and door trim. These architectural treatments and colour scheme are similar to the existing dwelling which is shown in

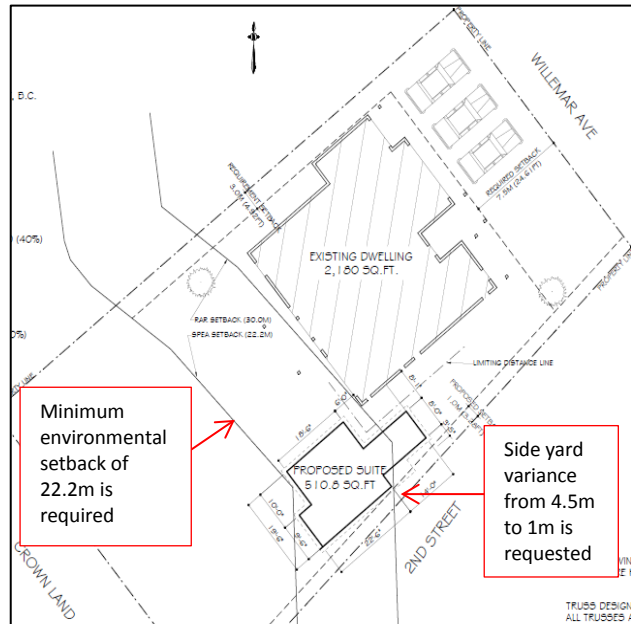

Figure 2. Site plan showing secondary dwelling proposal in relation to principal dwelling and property lines, the variance request and environmental setback requirement.



Figure 3. Side yard view of principal dwelling from 2<sup>nd</sup> Street. Secondary residence would be located behind fence.



Figure 4. 2<sup>nd</sup> Street side yard view of proposed secondary residence location. Fencing will be replaced and length will be increased as part of the landscaping plan.

Figures 5 and 6.

The property is already landscaped and partially fenced. The submitted landscape plan indicates that additional fencing will be added to the side yard in which the secondary dwelling unit is located to enhance privacy and screening from 2<sup>nd</sup> Street. Native vegetation is also required as part of the landscaping plan within the riparian enhancement area at the rear of the property, much of which is visible from the 2<sup>nd</sup> Street side yard. Parking for the secondary dwelling is provided in the existing front yard driveway.



Figure 5. Rendering of secondary residence showing the rear yard façade.



Figure 6. Front yard view of principal dwelling from Willemar Ave.

OCP Environmental Development Permit Guidelines

The development proposal is subject to the Riparian Area Regulation (RAR) provincial requirements which have determined the minimum setback that a building may be located from Morrison Creek. The setback is 22.2m as is shown in Figure 2. The applicant has included restoration in replacement of a large big leaf maple tree that was assessed as hazardous and removed last summer. The EDP guidelines require additional restoration and fencing of the riparian area located on the applicant’s property which also forms part of the drafted Permit.

Zoning Bylaw Review

The primary residence conforms to the zoning setbacks and other zoning requirements. The addition of the proposed detached secondary dwelling unit would continue to conform with all of the zoning requirements described in the Table 1 below, with the exception of the side yard setback adjacent 2<sup>nd</sup> street.

| Table 1: Proposal’s achievement of relevant zone requirements |   |   |
|---|---|---|
|   | <u>Required</u>   | <u>Secondary Residence Proposal</u>   |
| Total Floor Area of secondary residence (maximum)             | 90 m <sup>2</sup>   | 47.5m <sup>2</sup>  |
| Yard setbacks (minimum)                                       | Front: 7.5m<br>Side interior: 1.5m<br><b>Side adjacent a street: 4.5m</b><br>Rear: 9.0m | Front: 8.76m (of principal residence)<br>Side interior: 1.5m (of principal residence)<br><b>Side adjacent a street: 1.0m</b><br>Rear: 13.6m |
| Height of secondary residence (maximum)                       | 5.5m  | 4.47m   |

| Table 1: Proposal’s achievement of relevant zone requirements |   |  |
|---|---|--|
|   | <u>Required</u>   | <u>Secondary Residence Proposal</u>  |
| Total lot coverage (maximum)                                  | 40%   | 22%  |
| Parking Spaces (minimum)                                      | Three (Two for the principal dwelling unit and one for the secondary residence) | Six (A three car garage and adequate space for three spots in front yard driveway) |
| Parking coverage of frontage (maximum)                        | 50%   | 46%  |

The purpose of a 4.5m minimum side yard setback adjacent to a street is to minimize the presence of building massing from adjacent public roads. In this instance, the road is also a low traffic dead end street with only two other properties across 2<sup>nd</sup> Street accessing this short segment of road. The proposed secondary dwelling will be screened from 2<sup>nd</sup> Street, and is only one storey with a maximum roof height of 4.5m at the vaulted roofline peak, thus limiting the massing presence to the street.

Further, the grassed portion of the adjacent road boulevard is approximately 6.4m, lending the impression that the subject property’s side yard is wider than it is (Figure 7). This portion of 2<sup>nd</sup> Street is not expected to be upgraded to include sidewalks given the limited number of properties it services and its lack of connectivity, therefore this additional setback on public land is expected to continue to exist.

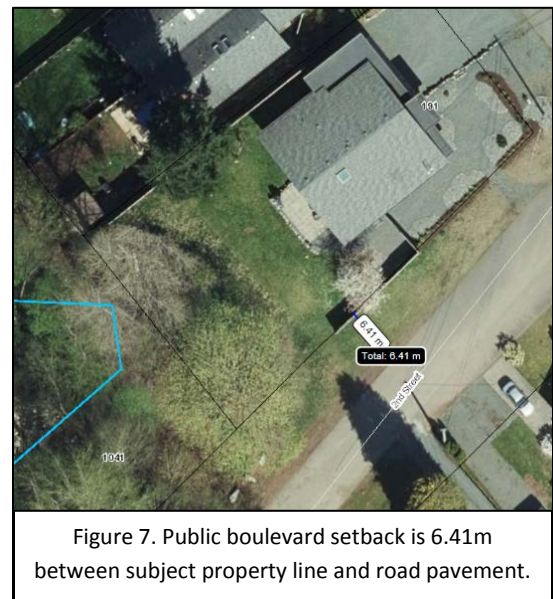

Figure 7. Public boulevard setback is 6.41m between subject property line and road pavement.

Staff consider the variance minor. The environmental setbacks limit the amount of developable area on the property thus restricting the opportunity for a detached secondary residence (Figure 2).

**FINANCIAL IMPLICATIONS:**

Application fees have been collected in order to process the Development Permit with Variances application. Should the proposed Development Permit with Variances be approved, a Building Permit and associated application fees will apply.

Properties with a secondary residence are charged a second utility fee (sewer, water, garbage) for the additional dwelling unit. Should the Development Permit with Variances be approved, the additional utility fees will be charged to the property at the time of occupancy permit. Secondary dwellings as well as secondary suites are exempt from paying Development Cost Charges to the City and Regional District.



**ADMINISTRATIVE IMPLICATIONS:**

The processing of development applications is included in the current work plan as a statutory component. To date, staff have spent ten hours reviewing the application, conducting review of the plans and coordinating with the applicant to request additional information.

If approved, there will be approximately four additional hours of staff time required to prepare the notice of permit, have it registered on title, administer the Environmental Development Permit restoration and monitoring conditions, and close the file. Additional staff time will be required for processing and issuing a building permit and related inspections.

**ASSET MANAGEMENT IMPLICATIONS:**

There are no direct asset management implications related to this application. This is an in-fill development that will utilize existing City infrastructure.

**STRATEGIC PRIORITIES REFERENCE:**

Development applications fall within Council’s area of control and specifically align with the strategic priority to support meeting the fundamental corporate and statutory obligations of the City. This application also meets the goal to support densification aligned with the Regional Growth Strategy.

**We support diversity in housing and reasoned land use planning**

- Support densification aligned with community input and regional growth strategy

**We focus on organizational and governance excellence**

- We support meeting the fundamental corporate and statutory obligations

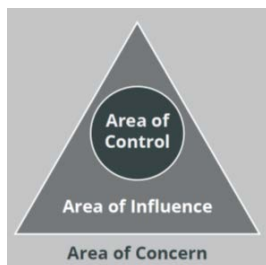

- **Area of Control**  
The policy, works and programming matters that fall within Council’s jurisdictional authority to act.

**OFFICIAL COMMUNITY PLAN REFERENCE:**

The proposed secondary residence represents infill residential development near existing amenities and services and fulfils the intent and the purpose of section 4.4.3 4 a) of the OCP - limited infill will be considered only in keeping with the character and scale of an existing neighbourhood.

**REGIONAL GROWTH STRATEGY REFERENCE:**

The development proposal is consistent with the RGS Housing Goal to “ensure a diversity of affordable housing options to meet evolving regional demographics and needs” including:

- Objective 1-A: Locate housing close to existing services; and
- Objective 1-C: Develop and maintain a diverse, flexible housing stock.

**CITIZEN/PUBLIC ENGAGEMENT:**

As per Council’s direction, under the IAP2 Spectrum of Public Participation the level of public input that has been undertaken is “**Consult**”.

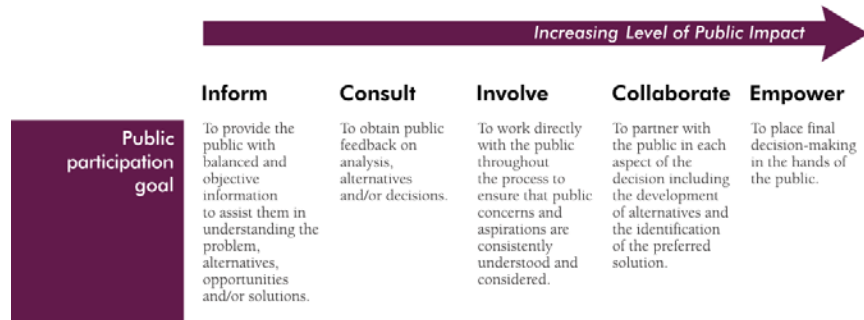

Property owners and occupants within 100 meters of the property were advised of the variance request through the rezoning application Public Information Meeting, which was held on September 8, 2017. A review of the comments from that meeting indicates no public concerns regarding the variance request.

Public notice was also sent to property owners and occupants who reside within 30 meters of the property lines as part of statutory public notice requirements for variance applications. To date, Development Services has not received any responses or inquiries from this notice.

**OPTIONS:**

**OPTION 1:** (Recommended): Approve Development Permit with Variances No. 1731

**OPTION 2:** Defer issuance of Development Permit with Variances No. 1731 pending receipt of further information.

**OPTION 3:** Not approve Development Permit with Variances No. 1731.

Prepared by:

Nancy Gothard, MCIP, RPP  
Policy Planner

Approved by:

Ian Buck, MCIP, RPP  
Director of Development Services

**Attachments:**

1. Attachment No. 1: Applicant’s rationale for variance request
2. Attachment No. 2: Draft Development Permit No. 1731



**From:** [Magnusson, Joy](#)  
**To:** [Gothard, Nancy](#)  
**Subject:** Rationale for variance of side yard setback  
**Date:** December-06-17 10:28:56 AM  
**Attachments:** [image001.jpg](#)

---

The building envelope that exists will not be able to maintain the side yard setback at 2<sup>nd</sup> street for the following reasons:

- 1) Privacy between the main dwelling and the proposed secondary suite
- 2) Riparian area limits the ability to build within the current envelope
- 3) The proposed secondary suite needs to have a livable amount of space (sqft)

Joy Magnusson, BSc(OT)  
Occupational Therapist  
Home and Community Care  
941A England Avenue  
Courtenay BC V9N 2N7  
Phone: 250-331-8522 Ext. 68382  
Fax: 250-331-8523

**THE CORPORATION OF THE CITY OF COURTENAY**

**Permit No.** DPwV 1731

**DEVELOPMENT PERMIT**

February 20, 2018

**To issue a Development Permit with Variances**

**To:**

Name: Joy Magnusson  
Address: 191 Willemar Ave.  
Courtenay, B.C. V9N 3L3

**Property to which permit refers:**

Legal: Lot D, Section 79, Comox District, Plan 18822  
Civic: 191 Willemar Ave.

**Conditions of Permit:**

Permit issued to allow the construction of a detached secondary dwelling subject to the following variance to the *City of Courtenay Zoning Bylaw No. 2500, 2007*:

- Section 8.2.7(3) - Notwithstanding the setback requirement in this Section, the minimum setback of the permitted detached secondary dwelling from 2<sup>nd</sup> Street may be reduced from 4.5m to 1.0m.

Development Permit with Variance No. 1731 is subject to the following conditions:

- a) Development must be in accordance with the plans and elevations contained in *Schedule No.1*;
- b) Development must be in accordance with the Riparian Area Assessment contained in *Schedule No.2*;
- c) Installation of riparian landscaping must be in conformance with the plans and specifications contained in *Schedule No. 3*, under the supervision of a Registered Professional Biologist;
- d) The riparian restoration area setback as shown in *Schedule No. 3* must be fenced prior to occupancy permit;
- e) The Registered Professional Biologist must conduct the monitoring activities as described in *Schedule No.2* and must provide a letter to the City upon construction completion that all monitoring conditions were followed;
- f) Submission of riparian restoration landscaping and environmental monitoring security in the amount of \$389.00;

- g) No surfaces may be paved or asphalted within the 30m Riparian Area Assessment area;
- h) Fencing along 2<sup>nd</sup> Street is to be installed and existing landscaping is to be maintained in general conformance with *Schedule No. 4*;
- i) No alterations or amendments shall be made without the City's permission. If any amendments are required the applicant shall apply for either an amendment to the development permit or a new development permit.

**Time Schedule of Development and Lapse of Permit**

That if the permit holder has not substantially commenced the construction authorized by this permit within (12) months after the date it was issued, the permit lapses.

\_\_\_\_\_  
Date

\_\_\_\_\_  
Director of Legislative Services



DPwV1731

Schedule No. 1: Plans and Elevations  
 Page 2 of 27

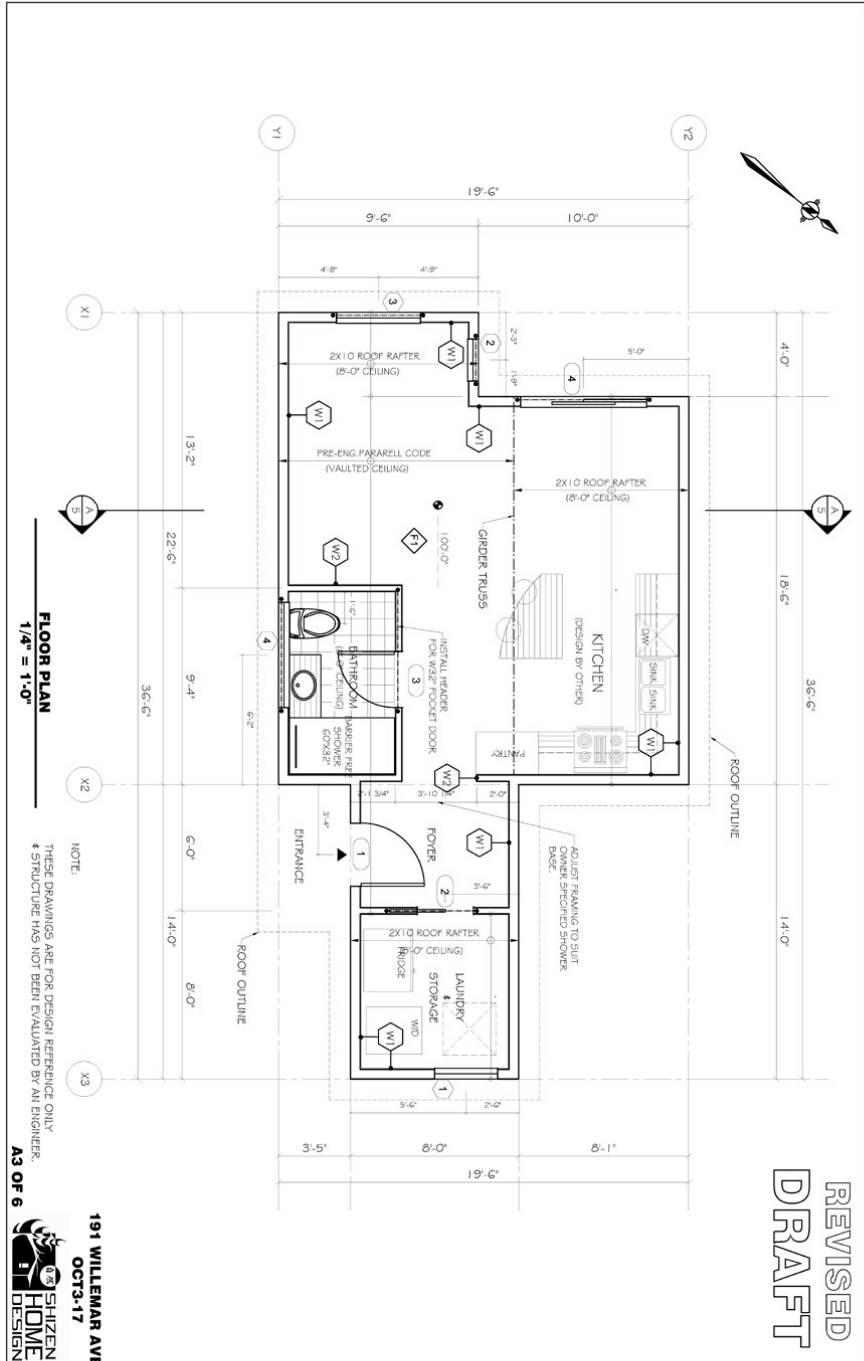

DPwV1731

Schedule No. 1: Plans and Elevations  
 Page 3 of 27

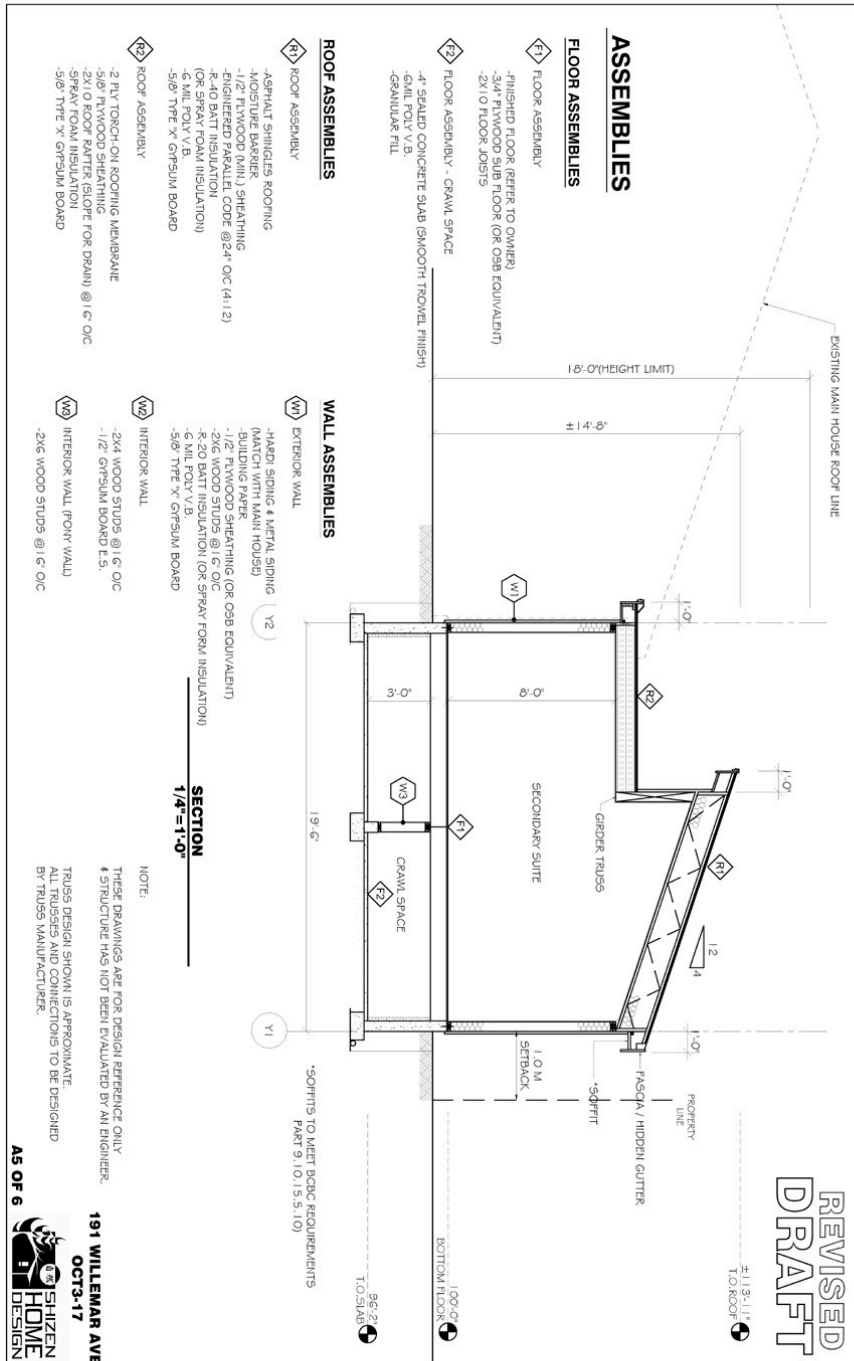

DPwV1731

Schedule No. 1: Plans and Elevations  
 Page 4 of 27

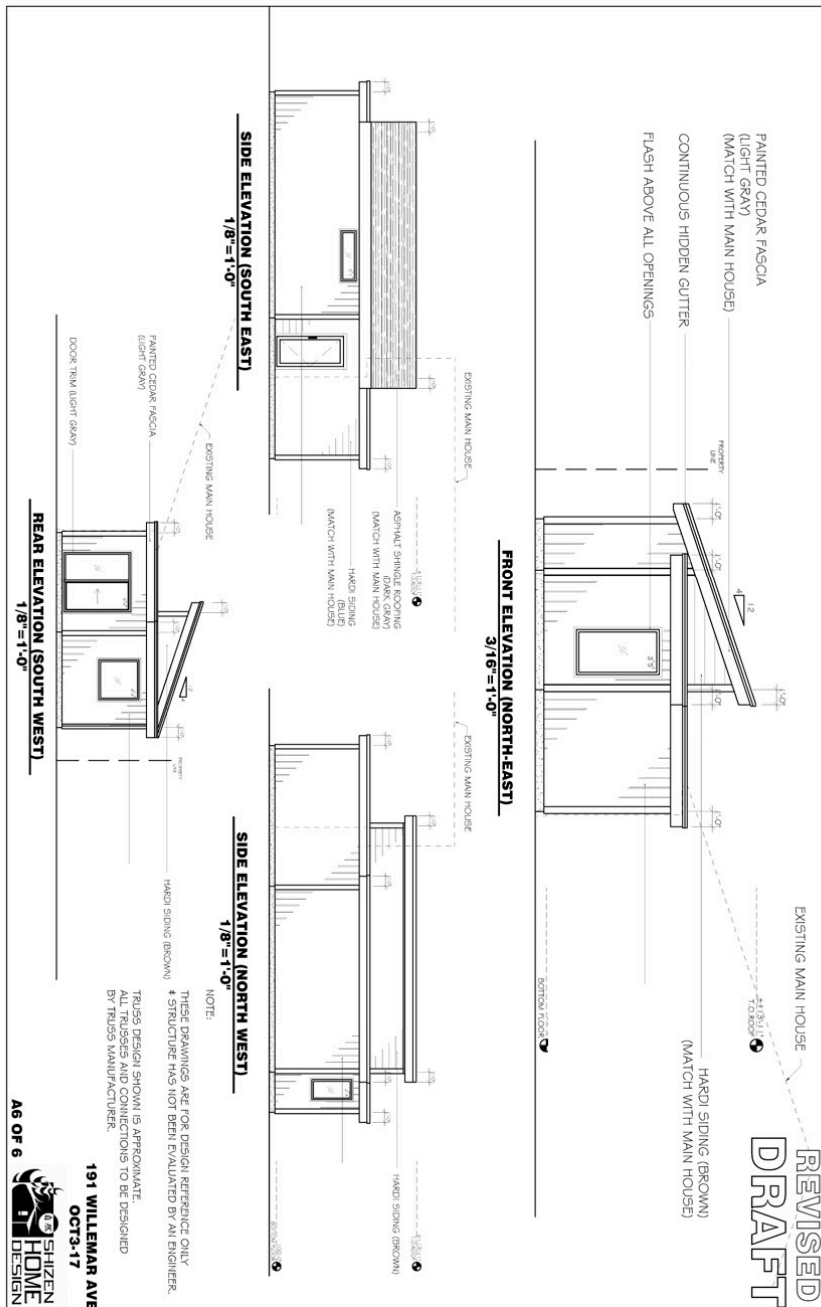

DPwV1731

Schedule No. 1: Plans and Elevations  
Page 5 of 27

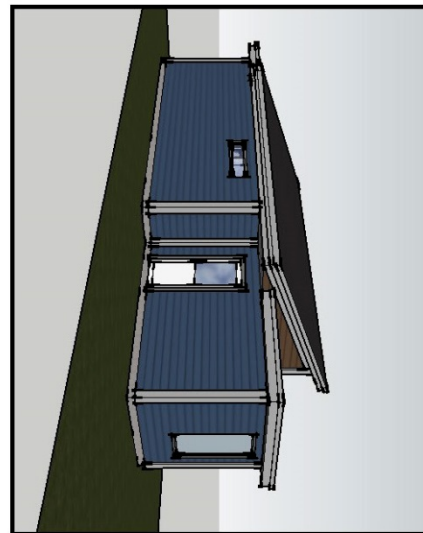
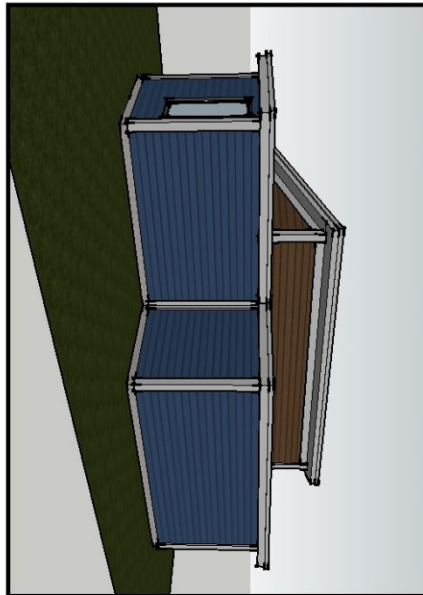

**PROJECT:**  
**191 WILLEMAR AVE**

**DRAWINGNAME:**  
HOUSE IMAGE





DPwV1731

Schedule No.2: Riparian Area Assessment  
 Page 6 of 27

FORM 1  
 Riparian Areas Regulation - Qualified Environmental Professional - Assessment Report

**Riparian Areas Regulation: Assessment Report**

Please refer to submission instructions and assessment report guidelines when completing this report.

Date 12 October, 2017

**I. Primary QEP Information**

|                |                    |             |                            |
|----------------|--------------------|-------------|----------------------------|
| First Name     | Warren             | Middle Name |                            |
| Last Name      | Fleenor            |             |                            |
| Designation    | R.P.Bio.           | Company     | Current Environmental Ltd. |
| Registration # | 1385               | Email       | wfleenor@shaw.ca           |
| Address        | 558 England Avenue |             |                            |
| City           | Courtenay          | Postal/Zip  | V9N 2N3                    |
| Prov/state     | BC                 | Country     | Canada                     |
|                |                    | Phone #     | 250-871-1944               |

**II. Secondary QEP Information (use Form 2 for other QEPs)**

|                |  |             |  |
|----------------|--|-------------|--|
| First Name     |  | Middle Name |  |
| Last Name      |  |             |  |
| Designation    |  | Company     |  |
| Registration # |  | Email       |  |
| Address        |  |             |  |
| City           |  | Postal/Zip  |  |
| Prov/state     |  | Country     |  |
|                |  | Phone #     |  |

**III. Developer Information**

|            |                     |             |                       |
|------------|---------------------|-------------|-----------------------|
| First Name | Joy                 | Middle Name |                       |
| Last Name  | Magnusson           |             |                       |
| Company    |                     |             |                       |
| Phone #    | 250-792-0621        | Email       | joy.magnusson@viha.ca |
| Address    | 191 Willemar Avenue |             |                       |
| City       | Courtenay           | Postal/Zip  | V9N 3L3               |
| Prov/state | BC                  | Country     | Canada                |

**IV. Development Information**

|                          |   |                       |                |
|--------------------------|---|-----------------------|----------------|
| Development Type         | Construction: Single Family Residential |                       |                |
| Area of Development (ha) | 0.005                                   | Riparian Length (m)   | 25             |
| Lot Area (ha)            | 0.11                                    | Nature of Development | Re-development |
| Proposed Start Date      | 1 Feb 2018                              | Proposed End Date     | 15 June 2018   |

**V. Location of Proposed Development**

|                                  |                        |          |                  |
|----------------------------------|------------------------|----------|------------------|
| Street Address (or nearest town) | 191 Willemar Avenue    |          |                  |
| Local Government                 | City of Courtenay      | City     | Courtenay        |
| Stream Name                      | Morrison Creek         |          |                  |
| Legal Description (PID)          | 003-776-557            | Region   | Vancouver Island |
| Stream/River Type                | Stream                 | DFO Area | South Coast      |
| Watershed Code                   | 920-553200-94200-04800 |          |                  |
| Latitude                         | 49                     | 41       | 08               |
| Longitude                        | 125                    | 00       | 56               |

Completion of Database Information includes the Form 2 for the Additional QEPs, if needed. Insert that form immediately after this page.

DPwV1731

Schedule No.2: Riparian Area Assessment  
Page 7 of 27

FORM 1  
Riparian Areas Regulation - Qualified Environmental Professional - Assessment Report

**Table of Contents for Assessment Report**

|  | <b>Page Number</b> |
|--|--------------------|
| 1. Description of Fisheries Resources Values   | 3                  |
| 2. Results of Riparian Assessment (SPEA width) | 5                  |
| 3. Site Plan                                   | 7                  |
| 4. Measures to Protect and Maintain the SPEA   | 9                  |
| 1. Danger Trees                                | 9                  |
| 2. Windthrow                                   | 9                  |
| 3. Slope Stability                             | 9                  |
| 4. Protection of Trees                         | 9                  |
| 5. Encroachment                                | 10                 |
| 6. Sediment and Erosion Control                | 11                 |
| 7. Stormwater Management                       | 12                 |
| 8. Floodplain                                  | 12                 |
| 5. Environmental Monitoring                    | 14                 |
| 6. Photos                                      | 15                 |
| 7. Assessment Report Professional Opinion      | 17                 |

Form 1

Page 2 of 17

DPwV1731

Schedule No.2: Riparian Area Assessment  
Page 8 of 27

FORM 1  
Riparian Areas Regulation - Qualified Environmental Professional - Assessment Report

**Section 1. Description of Fisheries Resources Values and a Description of the Development proposal**

(Provide as a minimum: Species present, type of fish habitat present, description of current riparian vegetation condition, connectivity to downstream habitats, nature of development, specific activities proposed, timelines)

**Fisheries Resource Values**

Morrison Creek is a highly valued and regionally significant 3rd order stream located on the east coast of Vancouver Island in Courtenay, BC. Morrison Creek flows for approximately 7.6 km in a northeasterly direction and drains a sub-basin area of approximately 890 ha. An estimated 60% (540 ha) of Morrison Creek watershed is located in headwater reaches characterized by 90 ha of wetland complexes. These headwater reaches provide cool, clean year-round water supply with relatively constant temperatures and flow that is ideally suited for fish production. Riparian habitat in the forested wetlands of the headwaters and the upper and middle watershed remain relatively intact and unfragmented compared to the lower portion of the watershed, which is undergoing increasing urbanization.

Morrison Creek is a major tributary to the Puntledge River and a highly productive anadromous fish stream supporting four Pacific salmon species (pink, chum, chinook, and coho), and three trout species (rainbow, steelhead, and cutthroat). Anadromous fish distribution includes the entire length of Morrison Creek with some unconfirmed utilization in the uppermost headwater reaches. No fish were observed during the assessment process in the stream reach adjacent to the subject property.

Morrison Creek also supports a population of the Morrison Creek lamprey<sup>1</sup>, a species endemic to the watershed. The Morrison Creek Lamprey was designated as Endangered by COSEWIC in 2000 and is protected under the federal *Species at Risk Act (SARA)*<sup>2</sup>. In general, it is known that Morrison Creek Lamprey require cool, flowing water over small gravel substrate for spawning and share habitat similar to what is ideally suited for rearing coho. After emergence, juvenile lamprey burrow into soft sediments where they live for 3-7 years as filter feeding ammocete larvae before metamorphosing into free-swimming adults. The local streamkeepers group, the Morrison Creek Streamkeepers (MCS), is an active steward of the SARA listed Morrison Creek Lamprey and is presently collecting data to help characterize the habitat requirements of this species, which is not well understood.

The stream is located southwest of the property boundary at 191 Willemar Avenue. A section of approximately 25 m of the stream is located close enough to the property that the 30 m Riparian Assessment Area (RAA) extends on to the subject property as far as the existing single family residence, and encompasses the proposed development.

This section of Morrison Creek was restored by the MCS and Current Environmental Ltd in 2015; an old wooden weir was removed from the stream channel affecting the subject property, and replaced with a series of riffles and pools. Large woody debris was also added along the streambanks, increasing habitat function and stabilizing banks. The work completed by MCS and Current Environmental is evident, and the habitat values in this section of Morrison Creek are

<sup>1</sup> Morrison Creek Streamkeepers. Life history and background info on the federally endangered Morrison Creek lamprey. Accessed from <<http://www.morrisoncreek.org/inclamprey.php>>.

<sup>2</sup> Species at Risk Public Registry. Species Profile. Morrison Creek Lamprey. Accessed from <[http://www.sararegistry.gc.ca/species/speciesDetails\\_e.cfm?sid=593](http://www.sararegistry.gc.ca/species/speciesDetails_e.cfm?sid=593)>

DPwV1731

Schedule No.2: Riparian Area Assessment  
Page 9 of 27

FORM 1

Riparian Areas Regulation - Qualified Environmental Professional - Assessment Report

high. Gravel substrates along the majority of this section are suitable for spawning. The series of riffles and pools that provide excellent habitat for juvenile salmonids. Revegetation with native species was included as a part of this restoration project. The riparian vegetation along the subject property is characterized by an alder forest with some mature cottonwood scattered in the area. Small cedars and bigleaf maples are also present. Understory is predominantly salmonberry, swordfern, horsetails, false lily-of-the-valley, skunk cabbage, Robert geranium, and grasses. Morning glory and some invasive blackberry were noted in riparian vegetation and near the edge of the grass lawn.

**Proposed Development**

The proposed development, still in the design and planning stages, is a new accessory building (secondary suite) on a lot with an existing single family residence. The new suite has a footprint of approximately 47.5 m<sup>2</sup>. A new fence will also be constructed parallel to 2<sup>nd</sup> Street, and will extend towards Morrison Creek as far as the new secondary suite. The proposed sitings of the suite and fence are within the 30 m RAA, and entirely outside of the 22.2 m SPEA. A restoration plan is being developed by Current Environmental with input from Morrison Creek Streamkeepers and the City of Courtenay, which will incorporate planting of native species on the subject property and adjacent Crown land, pending provincial approval.

*Changes from Previous Design*

The previous RAR submitted in support of this development included an addition to an existing residence. This has now been replaced with a standalone secondary suite. An existing fence will be extended to parallel 2<sup>nd</sup> Street, which was not included in the previous iteration. One entrance to the secondary suite opens on to the SPEA (Figure 2). This doorway is not anticipated to have significant impact to the SPEA in its existing state. The area within the SPEA adjacent to the doors is limited to yard space. No impermeable surfacing, steps, or structures will be constructed outside this door.

DPwV1731

Schedule No.2: Riparian Area Assessment  
 Page 10 of 27

FORM 1  
 Riparian Areas Regulation - Qualified Environmental Professional - Assessment Report

**2. Results of Detailed Riparian Assessment**

Refer to Chapter 3 of Assessment Methodology

Date: 12 October, 2017

Description of Water bodies involved (number, type)

1, stream

|         |   |
|---------|---|
| Stream  | 1 |
| Wetland |   |
| Lake    |   |
| Ditch   |   |

Number of reaches 1

Reach # 1

**Channel width and slope and Channel Type (use only if water body is a stream or a ditch, and only provide widths if a ditch)**

| Channel Width(m)       |      | Gradient (%) |     |
|------------------------|------|--------------|-----|
| starting point         | 6.6  |              |     |
| upstream               | 5.7  | 2.5          |     |
|                        | 6.5  |              |     |
|                        | 5.9  |              |     |
|                        | 6.0  |              |     |
| downstream             | 7.0  |              |     |
|                        | 10.3 |              |     |
|                        | 14.1 |              |     |
|                        | 8.5  | 2.5          |     |
|                        | 9.9  |              |     |
|                        | 3.8  |              |     |
| Total: minus high /low | 66.4 |              |     |
| mean                   | 7.4  |              |     |
|                        | R/P  | C/P          | S/P |
| Channel Type           | x    |              |     |

I, Warren Fleenor, hereby certify that:  
 a) I am a qualified environmental professional, as defined in the Riparian Areas Regulation made under the *Fish Protection Act*;  
 b) I am qualified to carry out this part of the assessment of the development proposal made by the developer Joy Magnusson;  
 c) I have carried out an assessment of the development proposal and my assessment is set out in this Assessment Report; and  
 d) In carrying out my assessment of the development proposal, I have followed the assessment methods set out in the Schedule to the Riparian Areas Regulation.

**Site Potential Vegetation Type (SPVT)**

| SPVT Polygons |  | Yes | No | Tick yes only if multiple polygons, if No then fill in one set of SPVT data boxes |
|---------------|--|-----|----|---|
|               |  |     | x  |   |

Polygon No: 1

SPVT Type: LC SH TR

Method employed if other than TR: x

I, Warren Fleenor, hereby certify that:  
 a) I am a qualified environmental professional, as defined in the Riparian Areas Regulation made under the *Fish Protection Act*;  
 b) I am qualified to carry out this part of the assessment of the development proposal made by the developer Joy Magnusson;  
 c) I have carried out an assessment of the development proposal and my assessment is set out in this Assessment Report; and  
 d) In carrying out my assessment of the development proposal, I have followed the assessment methods set out in the Schedule to the Riparian Areas Regulation.

**Zone of Sensitivity (ZOS) and resultant SPEA**

|   |      |   |
|---|------|---|
| Segment No:                             | 1    | If two sides of a stream involved, each side is a separate segment. For all water bodies multiple segments occur where there are multiple SPVT polygons |
| LWD, Bank and Channel Stability ZOS (m) | 22.2 |   |

DPwV1731

Schedule No.2: Riparian Area Assessment  
 Page 11 of 27

FORM 1  
 Riparian Areas Regulation - Qualified Environmental Professional - Assessment Report

Litter fall and insect drop ZOS (m)

Shade ZOS (m) max  South bank  Yes  No  x

**SPEA maximum**  (For ditch use table3-7)

I, Warren Fleenor, hereby certify that:  
 a) I am a qualified environmental professional, as defined in the Riparian Areas Regulation made under the *Fish Protection Act*;  
 b) I am qualified to carry out this part of the assessment of the development proposal made by the developer Joy Magnusson;  
 c) I have carried out an assessment of the development proposal and my assessment is set out in this Assessment Report; and  
 d) In carrying out my assessment of the development proposal, I have followed the assessment methods set out in the Schedule to the Riparian Areas Regulation.

**Comments**

**Morrison Creek**  
 A prescribed SPEA width of 22.2 m was calculated for the riparian assessment areas of Morrison Creek based on the calculated zones of sensitivity (ZOS) for the various features, functions and conditions (FFC).

Zones of sensitivity determined for relevant features, functions and conditions of the riparian assessment area:

| CHANNEL TYPE | CHANNEL WIDTH | SPVT | LWD    | LITTER FALL | SHADE |
|--------------|---------------|------|--------|-------------|-------|
| RP           | 7.4 m         | TR   | 22.2 m | 15.0 m      | 0 m   |

The following formulas and data were used to calculate a 22.2 m SPEA width for Morrison Creek near the subject property:

**Channel Morphology:**  
 Average bank full width (bfw) = 7.4 m  
 Average gradient = 2.5%

**Channel Type** (based on avg. gradient and bfw) = **Riffle-pool**

**Zones of Sensitivity:**

- LWD, Channel and bank stability (SPVT TR) = 3 x avg. bfw = 22.2 m
- Litter Fall = 3 x avg. bfw = 15.0 m (maximum)
- Shade = Shade ZOS 3 x avg. bfw = 0 m\*  
 \*Applicable to south bank only.

**Overall SPEA for Morrison Creek = 22.2 m**

DPwV1731

Schedule No.2: Riparian Area Assessment  
Page 12 of 27

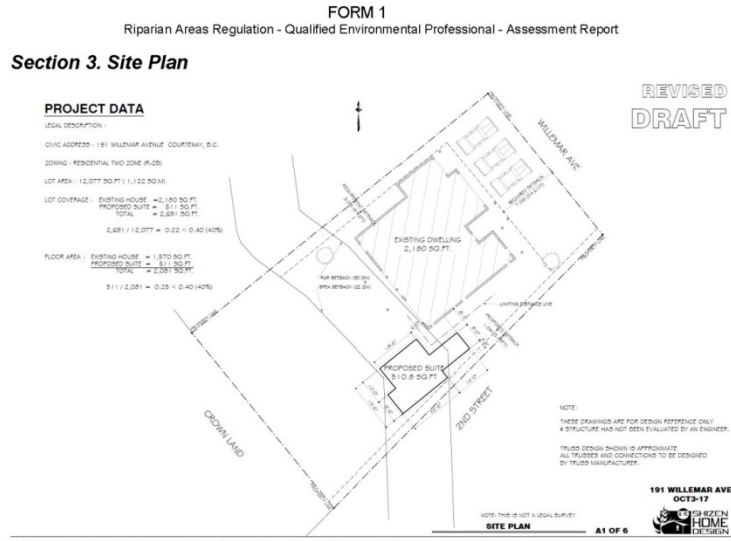

Figure 1. Preliminary site plan showing siting of the new addition on the subject property.

DPwV1731

Schedule No.2: Riparian Area Assessment  
Page 13 of 27

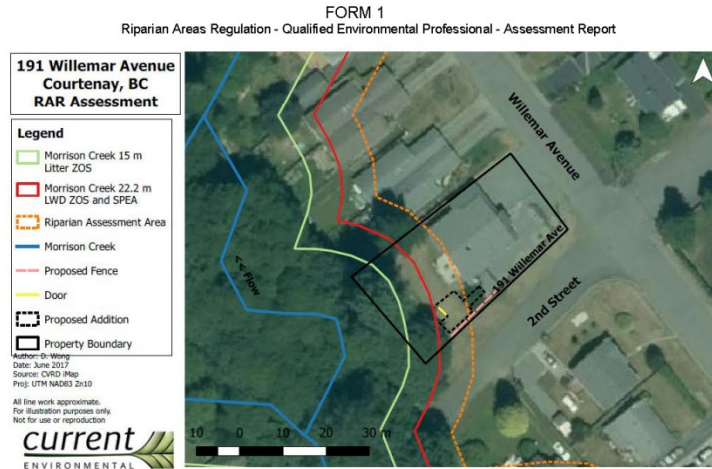

Figure 2. Site plan showing Morrision Creek as it affects the proposed development on the subject property.



DPwV1731

Schedule No.2: Riparian Area Assessment  
 Page 14 of 27

FORM 1  
 Riparian Areas Regulation - Qualified Environmental Professional - Assessment Report

**Section 4. Measures to Protect and Maintain the SPEA**

This section is required for detailed assessments. Attach text or document files, as need, for each element discussed in chapter 1.1.3 of Assessment Methodology. It is suggested that documents be converted to PDF before inserting into the assessment report. Use your "return" button on your keyboard after each line. You must address and sign off each measure. If a specific measure is not being recommended a justification must be provided.

|  |  |
|--|--|
| <b>1. Danger Trees</b>   |  |
| I, <u>Warren Fleenor</u> , hereby certify that:  |  |
| a. I am a qualified environmental professional, as defined in the Riparian Areas Regulation made under the <i>Fish Protection Act</i> ;  |  |
| b. I am qualified to carry out this part of the assessment of the development proposal made by the developer <u>Joy Magnusson</u> ;  |  |
| c. I have carried out an assessment of the development proposal and my assessment is set out in this Assessment Report; and In carrying out my assessment of the development proposal, I have followed the assessment methods set out in the Schedule to the Riparian Areas Regulation |  |
| The trees on/adjacent to the subject property are relatively young and do not appear to be hazard trees.   |  |
| <b>2. Windthrow</b>  |  |
| I, <u>Warren Fleenor</u> , hereby certify that:  |  |
| a. I am a qualified environmental professional, as defined in the Riparian Areas Regulation made under the <i>Fish Protection Act</i> ;  |  |
| b. I am qualified to carry out this part of the assessment of the development proposal made by the developer <u>Joy Magnusson</u> ;  |  |
| c. I have carried out an assessment of the development proposal and my assessment is set out in this Assessment Report; and In carrying out my assessment of the development proposal, I have followed the assessment methods set out in the Schedule to the Riparian Areas Regulation |  |
| The trees on/adjacent to the subject property are relatively young and do not appear to be prone to windthrow.   |  |
| <b>3. Slope Stability</b>  |  |
| I, <u>Warren Fleenor</u> , hereby certify that:  |  |
| a. I am a qualified environmental professional, as defined in the Riparian Areas Regulation made under the <i>Fish Protection Act</i> ;  |  |
| b. I am qualified to carry out this part of the assessment of the development proposal made by the developer <u>Joy Magnusson</u> ;  |  |
| c. I have carried out an assessment of the development proposal and my assessment is set out in this Assessment Report; and In carrying out my assessment of the development proposal, I have followed the assessment methods set out in the Schedule to the Riparian Areas Regulation |  |
| No triggers for slope stability issues were observed on the subject property. The property is relatively flat, and there is a slope towards Morrison Creek within the SPEA. The area of the proposed addition is outside of the SPEA, on flat ground.                                  |  |
| <b>4. Protection of Trees</b>  |  |
| I, <u>Warren Fleenor</u> , hereby certify that:  |  |
| a. I am a qualified environmental professional, as defined in the Riparian Areas Regulation made under the <i>Fish Protection Act</i> ;  |  |
| b. I am qualified to carry out this part of the assessment of the development proposal made by the developer <u>Joy Magnusson</u> ;  |  |
| c. I have carried out an assessment of the development proposal and my assessment is set out in this Assessment Report; and In carrying out my assessment of the development proposal, I have followed the assessment methods set out in the Schedule to the Riparian Areas Regulation |  |
| All of the vegetation, including trees and undergrowth, within the SPEA that does not currently pose a risk as assessed by a qualified arborist shall not be impacted in any way by the activities   |  |

DPwV1731

Schedule No.2: Riparian Area Assessment  
Page 15 of 27

FORM 1  
Riparian Areas Regulation - Qualified Environmental Professional - Assessment Report

of development on the subject property. It is important to protect as many trees as is safely possible within the 30 m Riparian Assessment Area (RAA) from mechanical damage, soil disturbance, or soil compaction during construction in order to prevent destabilizing the trees or causing tree mortality. In any forested areas near construction, care will need to be taken around large trees and snags. Construction activities outside, but adjacent to the SPEA will be limited to surficial "grubbing" only; no larger excavations that may endanger the root systems of the trees within the SPEA will be permitted.

In order to protect trees in the SPEA there shall be no: trenching through the root zone of trees, paving around trees, modifications to the ground level around trees, parking under trees, or concrete washout or other pollutants allowed to contaminate the soil around trees.

Other measures will include the following:

- 1) The SPEA is to be clearly flagged, fenced, and/or staked prior to ANY construction activities.
- 2) SPEA trees identified for retention prior to land clearing activity will be assessed by a certified arborist and their recommendations for protection will be adhered to during any land clearing activity adjacent to the SPEA.
- 3) Create/use access routes that avoid tree roots, storage of excavation/building material away from trees within SPEAs, and covering tree roots in access areas with at least 15 cm of wood chip mulch (or similar material) to avoid root compaction.
- 4) Trenching through the rooting zone of mature trees will be prevented.
- 5) Establish root protection zones around significant larger trees in the 30 m RAA. Root protection zones should be calculated by multiplying the diameter of the tree by 18. This value is the radius of the area of land surrounding the trunk of a tree that is to be avoided.
- 6) Monitor the impacts of construction activities. If roots have been cut make sure they weren't shattered by heavy equipment. Broken roots should be cut cleanly with a saw.
- 7) Mulch about the base of trees to retain moisture.
- 8) Vertical mulching may be necessary where roots have been severely impacted by machinery or fill.
- 9) Prune any broken limbs with clean cuts.
- 10) Ensure that pollutants and other contaminants cannot enter soils within the tree protection zone.

5. Encroachment

I, Warren Fleener, hereby certify that:

- a. I am a qualified environmental professional, as defined in the Riparian Areas Regulation made under the Fish Protection Act.
- b. I am qualified to carry out this part of the assessment of the development proposal made by the developer Joy Magnusson.
- c. I have carried out an assessment of the development proposal and my assessment is set out in this Assessment Report; and in carrying out my assessment of the development proposal, I have followed the assessment methods set out in the Schedule to the Riparian Areas Regulation

SPEA setback areas, and arborists' recommended protection zones outside of the SPEA (to protect trees within the SPEA) will be clearly delineated using flagged stakes (or equivalent) prior to the commencement of work.

During construction no machines/vehicles will park or otherwise access the setback. All work crew members should be aware of the sensitivity of the setback. No construction materials will be stockpiled in the setback.

The following activities will not be permitted in order to avoid impacting the SPEA.

DPwV1731

Schedule No.2: Riparian Area Assessment  
Page 16 of 27

FORM 1

Riparian Areas Regulation - Qualified Environmental Professional - Assessment Report

- 1) Disposal of material (e.g. yard waste) within the SPEA;
- 2) Long-term storage of materials within the SPEA;
- 3) Removal of native vegetation or soil within the SPEA;
- 4) Constructing permanent features within the SPEA.

The developer should contact the QEP three days prior to the commencement of construction activity for a pre-work meeting to discuss all measures and BMPs to protect aquatic resources.

6. Sediment and Erosion Control

I, Warren Fleeger, hereby certify that:

- a. I am a qualified environmental professional, as defined in the Riparian Areas Regulation made under the *Fish Protection Act*;
- b. I am qualified to carry out this part of the assessment of the development proposal made by the developer Joy Magnusson;
- c. I have carried out an assessment of the development proposal and my assessment is set out in this Assessment Report; and in carrying out my assessment of the development proposal, I have followed the assessment methods set out in the Schedule to the Riparian Areas Regulation.

The introduction of sediment into Morrison Creek, due to either erosion or deposition of sediment is the main concern during the clearing and construction phases. To avoid offsite release of sediment or other deleterious substances to the stream the mitigation measures summarized below and guidelines outlined in the following resources will be followed:

- 1) Fisheries and Oceans Canada (1993). Land Development Guidelines for the Protection of Aquatic Habitat. Accessed from <<http://www.dfo-mpo.gc.ca/Library/165353.pdf>>
- 2) Ministry of Environment (2007). A Users' Guide to Working In and Around Water: Understanding the Regulation Under British Columbia's *Water Act*. Accessed from <[http://www2.gov.bc.ca/assets/gov/farming-natural-resources-and-industry/natural-resource-use/land-water-use/crown-land/working\\_around\\_water.pdf](http://www2.gov.bc.ca/assets/gov/farming-natural-resources-and-industry/natural-resource-use/land-water-use/crown-land/working_around_water.pdf)>

Mitigation measures include the following:

- 1) The project biologist is to be notified 3 days prior to beginning construction. The biologist will ensure appropriate mitigation measures are in place.
- 2) No machinery is to enter riparian setback areas at any time.
- 3) The development will be designed with regard to the general principles of erosion and sediment control with particular attention to the following:
  - a. Maximize retention of existing vegetation and ground cover where possible;
  - b. Schedule construction to avoid coinciding with heavy precipitation;
  - c. Provide surfaced working areas and restrict vehicle access;
  - d. Minimize clearing and stripping of setbacks and easements;
  - e. Clearly mark lot areas and clearing boundaries on site.
- 4) Surface soil erosion from the development site will be generated primarily from soil excavation and graded areas. To minimize erosion the following guidelines should apply:
  - a. Protect stockpile material to minimize erosion (e.g. cover sheets or perimeter silt fencing);
  - b. Retain existing vegetation where possible and limit and/or stage clearing and stripping to only what is required;
  - c. Revegetate or landscape disturbed areas as soon as possible;
  - d. Limit vehicle and machine operation to prepared access areas only.
- 5) The following drainage and sediment control recommendations are made to limit the

DPwV1731

Schedule No.2: Riparian Area Assessment  
 Page 17 of 27

FORM 1  
 Riparian Areas Regulation - Qualified Environmental Professional - Assessment Report

- offsite transport of sediments to sensitive habitat:
- a. Divert runoff away from cleared areas using swales or low berms;
  - b. Collect onsite runoff into appropriately sized temporary or permanent detention facilities prior to discharge offsite;
  - c. As required, allow sufficient intervals for sediment to precipitate before releasing clear water off-site;
  - d. Utilize silt fences around stockpiles and along areas that slope towards any watercourses or wetlands.
- 6) The following recommendations are made to minimize risk of deleterious substances (e.g. sediment, raw/uncured concrete, mortar, glues, paint, lubricants, organic and inorganic contaminants, fuels/oils) entering the watercourse or groundwater sources:
- a. Conduct daily and routine site cleanup and disposal of waste material;
  - b. Equipment will be mechanically sound and free of leaking deleterious material and inspected regularly;
  - c. Spill kits will be kept with each machine and operators will be familiar with emergency procedures;
  - d. Wash down waters from exposed aggregate surfaces, cast-in-place concrete, and from concrete trucks and equipment will be trapped onsite for approximately 48 hrs to allow sediment to precipitate and achieve neutral pH before the clarified water is released to the storm drain system or allowed to percolate into the ground;
  - e. Fuels, lubricants and hydraulic fluids used on the subject property will be carefully managed to avoid spills, secured against unauthorized access and equipped with spill containment according to the codes of practice;
  - f. Accidental spillage of fuels, lubricants or hydraulic fluid must be immediately contained and the contaminated soil removed and disposed of in accordance with the Environmental Protection Branch of the Federal Department of the Environment (DOE/EP) and the provincial Ministry of Environment (MoE);
  - g. Rinse and cleaning water or solvents (for glues, paint, wood preservatives) and other potentially toxic substances on the subject property should be similarly controlled to prevent leakage, loss or discharge to the storm drain system or groundwater sources.

7. Stormwater Management

I, Warren Fleenor, hereby certify that:

- a. I am a qualified environmental professional, as defined in the Riparian Areas Regulation made under the *Fish Protection Act*;
- b. I am qualified to carry out this part of the assessment of the development proposal made by the developer Joy Magnusson;
- c. I have carried out an assessment of the development proposal and my assessment is set out in this Assessment Report; and In carrying out my assessment of the development proposal, I have followed the assessment methods set out in the Schedule to the Riparian Areas Regulation

The addition will use existing stormwater management infrastructure for the existing residence. Design features that help reduce impact to stormwater include: no eaves on buildings to allow drainage along long sections of the roof, a gravel driveway, stone paver patio (no slabs).

8. Floodplain Concerns (highly mobile channel)

I, Warren Fleenor, hereby certify that:

- a. I am a qualified environmental professional, as defined in the Riparian Areas Regulation made under the *Fish Protection Act*;
- b. I am qualified to carry out this part of the assessment of the development proposal made by the developer Joy Magnusson;
- c. I have carried out an assessment of the development proposal and my assessment is set out in this Assessment Report

DPwV1731

Schedule No.2: Riparian Area Assessment  
Page 18 of 27

FORM 1

Riparian Areas Regulation - Qualified Environmental Professional - Assessment Report

Report: and in carrying out my assessment of the development proposal, I have followed the assessment methods set out in the Schedule to the Riparian Areas Regulation

There are no floodplain concerns at the subject property. The stream channel is well confined and relatively stable, in part as a result of recent restoration works.

DPwV1731

Schedule No.2: Riparian Area Assessment  
Page 19 of 27

FORM 1

Riparian Areas Regulation - Qualified Environmental Professional - Assessment Report

**Section 5. Environmental Monitoring**

Attach text or document files explaining the monitoring regimen Use your "return" button on your keyboard after each line. It is suggested that all document be converted to PDF *before* inserting into the PDF version of the assessment report. Include actions required, monitoring schedule, communications plan, and requirement for a post development report.

The developer is to contact a Qualified Environmental Professional (QEP) three days prior to the commencement of construction work for an onsite meeting. The following tasks will be completed at the meeting:

- Ensure the setback area is clearly delineated;
- Review work plan;
- Ensure appropriate mitigation measures will be in place;
- Review all Measures to Protect the SPEA stated in this report and ensure appropriate equipment to satisfy the measures are on-site or available;
- Review emergency spill response plan;
- Set up a contact system should a biologist be required on site in the event of sediment/erosion issues or some other type of risk to aquatic habitats that may arise during construction.

Immediately upon completion of the construction work, the proponent is to contact a QEP for a post-construction site inspection. Any deficiencies noted by the QEP are to be addressed by the proponent. A final post-construction report is to be submitted by the QEP to the BC RAR Notification System.

DPwV1731

Schedule No.2: Riparian Area Assessment  
Page 20 of 27

FORM 1

Riparian Areas Regulation - Qualified Environmental Professional - Assessment Report

**Section 6. Photos**



Photo 1. View of the section of Morrison Creek adjacent to the subject property looking downstream showing recent riffle restoration work.



Photo 2. View (looking downstream from just upstream of the subject property) of the channel split and vegetated island on Morrison Creek.

DPwV1731

Schedule No.2: Riparian Area Assessment  
Page 21 of 27

FORM 1  
Riparian Areas Regulation - Qualified Environmental Professional - Assessment Report



Photo 3. Some of the anchored LWD added as part of the restoration work in 2015 by the Morrison Creek Streamkeepers.



Photo 4. View of the approximate proposed siting of the new addition on the subject property (red).



DPwV1731

Schedule No.2: Riparian Area Assessment  
Page 22 of 27

FORM 1

Riparian Areas Regulation - Qualified Environmental Professional - Assessment Report

**Section 7. Professional Opinion**

**Assessment Report Professional Opinion on the Development Proposal's riparian area.**

Date

1. I/We, Warren Fleenor,

Please list name(s) of qualified environmental professional(s) and their professional designation that are involved in assessment.

hereby certify that:

- a) I am/We are qualified environmental professional(s), as defined in the Riparian Areas Regulation made under the *Fish Protection Act*;
- b) I am/We are qualified to carry out the assessment of the proposal made by the developer Joy Magnusson, which proposal is described in section 3 of this Assessment Report (the "development proposal");
- c) I have/We have carried out an assessment of the development proposal and my/our assessment is set out in this Assessment Report; and
- d) In carrying out my/our assessment of the development proposal, I have/We have followed the assessment methods set out in the Schedule to the Riparian Areas Regulation; AND

2. As qualified environmental professional(s), I/we hereby provide my/our professional opinion that:

- a)  if the development is implemented as proposed by the development proposal there will be no harmful alteration, disruption or destruction of natural features, functions and conditions that support fish life processes in the riparian assessment area in which the development is proposed. **OR**  
(Note: include local government flex letter, DFO Letter of Advice, or description of how DFO local variance protocol is being addressed)
- b)  if the streamside protection and enhancement areas identified in this Assessment Report are protected from the development proposed by the development proposal and the measures identified in this Assessment Report as necessary to protect the integrity of those areas from the effects of the development are implemented by the developer, there will be no harmful alteration, disruption or destruction of natural features, functions and conditions that support fish life processes in the riparian assessment area in which the development is proposed.

[NOTE: "qualified environmental professional" means an applied scientist or technologist, acting alone or together with another qualified environmental professional, if  
(a) the individual is registered and in good standing in British Columbia with an appropriate professional organization constituted under an Act, acting under that association's code of ethics and subject to disciplinary action by that association,  
(b) the individual's area of expertise is recognized in the assessment methods as one that is acceptable for the purpose of providing all or part of an assessment report in respect of that development proposal, and  
(c) the individual is acting within that individual's area of expertise.]

DPwV1731

Schedule No.3: Riparian restoration  
Page 23 of 27

---

## Memorandum



---

|       |  |          |                     |
|-------|--|----------|---------------------|
| To:   | Nancy Gothard, City of Courtenay         | Date:    | 29 January, 2018    |
| From: | Warren Fleenor, RPBio<br>Danika Wong, EM | Pages:   | 4                   |
| Cc:   | Joy Magnusson, Proponent                 | Project: | 191 Willemar Avenue |

**Subject(s): Additional restoration opportunities**

---

### 1 INTRODUCTION

This memorandum is intended to accompany the Riparian Areas Regulation (RAR) assessment completed for the proposed secondary suite development at 191 Willemar Avenue (updated 12 October, 2017), as well as the previous restoration memorandum provided by Current Environmental Ltd. (dated 16 October, 2017). Restoration planting detailed in the 16 October memo has been completed at this time. This memo will outline the additional restoration and tree replacement plan for enhancing the setback area and replacement of a tree that will be removed within the footprint of the proposed development. Items 3, 4, 6, and 7 of the City of Courtenay review letter for development permit with variances No. 1731 (DPV00008) 191 Willemar Ave. (dated 10 January, 2017) will be addressed in this memo.

---

### 2 RESTORATION AND TREE REPLACEMENT PLANTING PLAN

#### 2.1 ADDITIONAL PLANTING

A restoration of an approximate width of 5 m from the southwest property boundary has been established and planted with the prescription from the previous restoration memo. Three bigleaf maple trees and five conifers were planted based on the previous memo as replacement trees for a maple tree removed as recommended by an arborist. In addition, in excess of 20 shrubs were planted to restore the SPEA. Finally, extensive mats of invasive Himalayan blackberry were removed within the SPEA, and the native plants previously covered by the blackberry were protected from landscaping and deer using flagging, wire fencing, and rock delineation.

To increase the restoration effort and area within the SPEA, it is recommended that additional conifers, two replacement trees (detailed below), and a small number of shrubs be planted. The conifers can be limited to the areas nearer Morrison Creek and within Crown land, as the new secondary suite will use passive heating techniques (direct solar gain) to reduce energy consumption, and large conifers will reduce solar exposure to the dwelling. Permission from the Province has been granted to plant native species on the Crown land adjacent to the subject property (email communication with Carl Morrison and Jenna Cragg of FLNRORD dated 15 January, 2018). Trees can be planted in suitable gaps within the previous planting area, or nearer the terminus of 2<sup>nd</sup> Street where vegetation is more sparse. The recommended planting area for the remaining replacement trees and shrubs is adjacent to the northwest property boundary. The replacement trees must be planted at least 1 m from the

DPwV1731

Schedule No.3: Riparian restoration  
 Page 24 of 27



property boundary per the Tree Protection and Management Bylaw No. 2850<sup>1</sup>. The recommended restoration planting is detailed in Table 1.

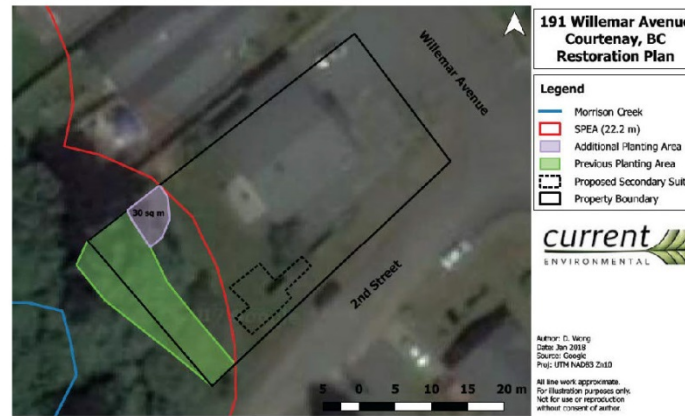

Figure 1. Plan showing the proposed location of the additional restoration within the SPEA.

Table 1 below details the prescribed species and quantities of plants for the restoration area, both Crown and private land, as well as the associated costs.

Table 1. Plant prescription for the restoration area, including tree replacement.

| Species         | Location                           | Number    | Size  | Spacing | Cost/Unit* | Total Cost     |
|-----------------|------------------------------------|-----------|-------|---------|------------|----------------|
| Thimbleberry    | Private land                       | 2         | 1 gal | 1 m     | \$5.50     | \$11.00        |
| Beaked hazelnut | Private land                       | 2         | 2 gal | 2 m     | \$4.75     | \$9.50         |
| Bitter cherry   | Private land<br>*replacement trees | 2         | 1 gal | 6 m     | \$4.75     | \$9.50         |
| Douglas-fir     | Crown land                         | 2         | 1 gal | 6 m     | \$4.75     | \$9.50         |
| Grand fir       | Crown land                         | 2         | 1 gal | 6 m     | \$4.75     | \$9.50         |
| Western Hemlock | Crown land                         | 2         | 1 gal | 6 m     | \$4.75     | \$9.50         |
| <b>Total</b>    |                                    | <b>12</b> |       |         |            | <b>\$58.50</b> |

\* Cost based on wholesale prices. Tax and labour are not included.

<sup>1</sup> City of Courtenay (2016). Tree Protection and Management Bylaw No. 2850. Accessed from <[http://www.courtenay.ca/assets/City~Hall/Bylaws/Land~Use/2850\\_Tree\\_Protection\\_Bylaw.pdf](http://www.courtenay.ca/assets/City%20Hall/Bylaws/Land%20Use/2850_Tree_Protection_Bylaw.pdf)>

DPwV1731

Schedule No.3: Riparian restoration  
 Page 25 of 27



**2.2 TREE REPLACEMENT PLAN**

One plum tree (two stems with a total 26 cm dbh) will be removed for the proposed secondary suite. Per the City's Tree Protection and Management Bylaw and the provincial Tree Replacement Criteria<sup>2</sup>, two native replacement trees must be planted. These trees can be sited with the recommended shrubs at the northwest boundary of the subject property.

**3 RESTORATION SECURITIES**

The table below summarizes the costs and associated securities for the restoration works and monitoring.

Table 2. Summary of the restoration securities for the subject property.

| Item                             | Cost/Item | Quantity | Total Cost | Deposit Required | Security Amount |
|----------------------------------|-----------|----------|------------|------------------|-----------------|
| Plants (total order planted)     | \$156.50  | 1        | \$156.50   | 20%              | \$31.30         |
| Plants (total order not planted) | \$58.50   | 1        | \$58.50    | 100%             | \$58.50         |
| Site visits (yearly)             | \$150.00  | 2        | \$300.00   | 100%             | \$300.00        |
| <b>Total</b>                     |           |          |            |                  | <b>\$389.80</b> |

**4 CLOSURE**

We trust this memorandum meets your requirements for additional restoration at 191 Willemar Avenue. Please contact the undersigned with any questions.

Current Environmental Ltd.



Warren Fleenor, R.P. Bio. & Danika Wong, Environmental Monitor

<sup>2</sup> Ministry of Environment (1996). Tree replacement criteria. Accessed from <<http://www.env.gov.bc.ca/wid/documents/bmp/treereplcrit.pdf>>

DPwV1731

Schedule No.3: Riparian restoration  
Page 26 of 27



PHOTOS

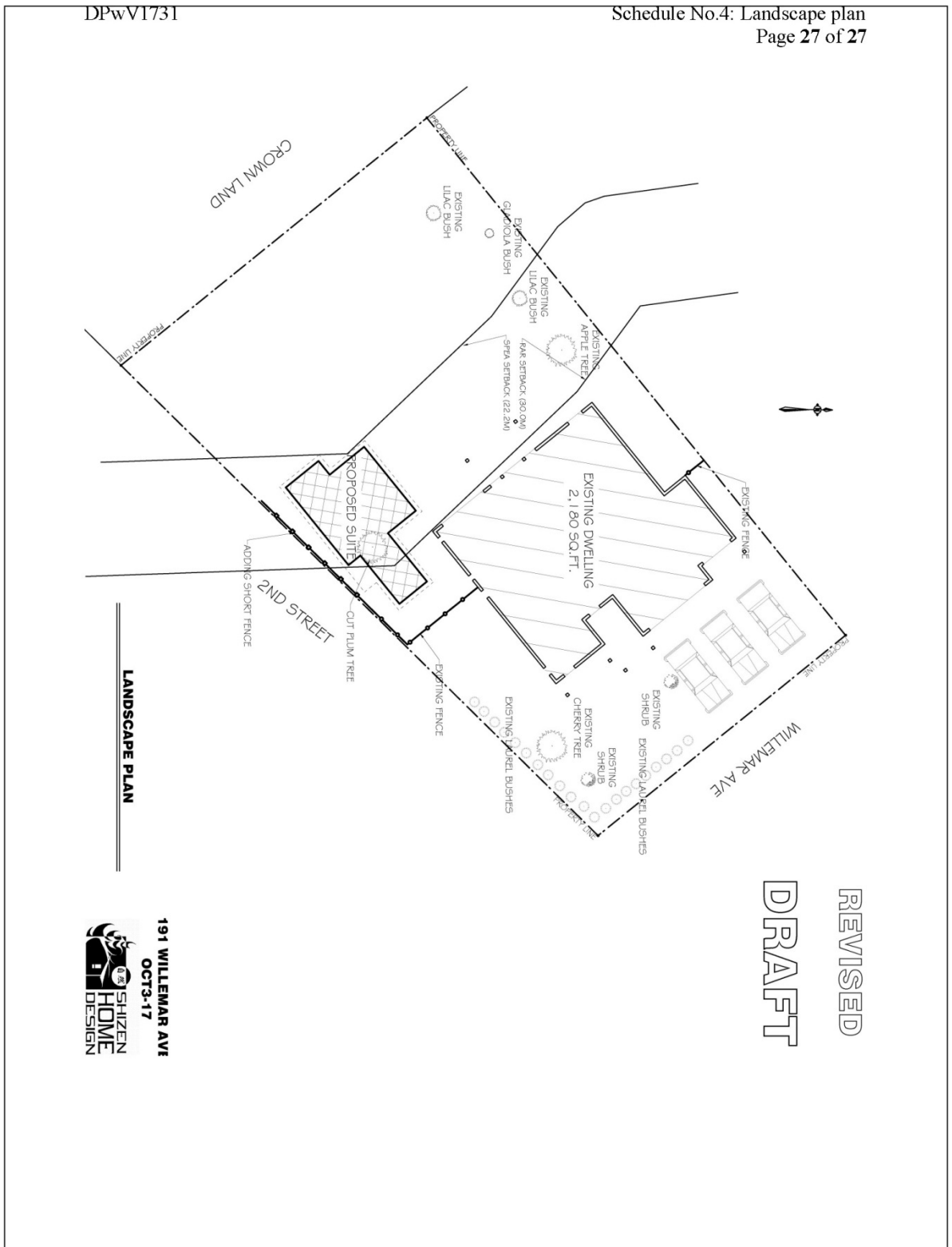

Photo 1. Proposed siting of plum replacement trees and some shrubs.



Photo 2. Tree to be removed (permit required).

191 Willemar Avenue – Restoration Plan





## BRIEFING NOTE

---

**To:** Council  
**From:** Chief Administrative Officer  
**Subject:** Lewis Park – Tree Removal

**File No.:** 6140-103  
**Date:** February 7<sup>th</sup>, 2018

---

### ISSUE

The purpose of this briefing note is to notify Council that one large Sitka Spruce tree located in Lewis Park, adjacent to the public washrooms at the West-end of the Park, requires immediate removal to mitigate potential risk to public safety and property.

### BACKGROUND:

On the morning of January 21<sup>st</sup>, 2018 a similar sized Sitka Spruce tree in Lewis Park fell during a wind and rain event. The tree, which sat adjacent to the Old Island Highway, fell inwards towards the park, causing no significant damage to public property.

The failure of this tree, which had not previously been identified as posing a high risk of failure through routine annual visual inspections, prompted further, more in-depth assessments of similar trees within the park. Between January 26<sup>th</sup> and February 2<sup>nd</sup>, 2018, thirteen coniferous trees in Lewis Park were assessed using the International Society of Arboriculture TRAQ Level 2 and Level 3 assessment techniques by the City's consulting Arborist, Peter Jungwirth. As a result, one tree was identified as exceeding our risk threshold.

### KEY CONSIDERATIONS:

Formal tree risk assessments consider a number of factors when assigning risk ratings. Tree health and structure, as well as site conditions, history and tree location are considered and analyzed. These are then used to determine the likelihood of failure and the severity of consequences should a failure occur.

Given the tree's location, which is directly adjacent to well used walkways, sports fields, buildings and vehicle parking, combined with the Arborist's findings of decreased health (i.e. 50% foliage loss) and structural defects (only 11 cm of sound wood on one side of base of tree), this tree was determined to constitute a moderate to high risk of failure. To mitigate this risk, the consulting Arborist recommended complete tree removal.

### FINANCIAL IMPLICATIONS

Tree removal, stump grinding and site restorations costs are approximately \$2,500. This will be funded within the 2018 operating budget.

Parks staff will undertake appropriate replacement tree planting within the park to align with the Tree Protection and Management Bylaw. These plantings are scheduled for October 2018.



## **PUBLIC ENGAGEMENT**

Public notifications will be prepared and posted in advance of the planned work to advise the public of the removal and the reasons that have led to this decision.



Respectfully submitted,

A handwritten signature in black ink, appearing to read "Mike Kearns".

Mike Kearns,  
Manager of Parks Maintenance

A handwritten signature in black ink, appearing to read "Trevor Kushner".

Trevor Kushner,  
Director of Public Works Services



# THE CORPORATION OF THE CITY OF COURTENAY

## BYLAW NO. 2919

### **A bylaw to regulate and require the provision of works and services in connection with the subdivision and development of land**

The Council of the Corporation of the City of Courtenay, in open meeting assembled, enacts as follows:

1. In this bylaw,

“Approving Officer” means the person appointed to that position under the *Land Title Act*, or a designate.

“Building Inspector” means a person designated to that position by the City of Courtenay.

“City” means the Corporation of the City of Courtenay.

“Construct” when used with respect to Works and Services referred to herein, means build, erect, install, repair, alter, add, enlarge, move, locate, relocate, rebuild, upgrade, demolish, remove, excavate or shore.

“Construction Costs” means the estimated construction costs of Works and Services as determined by the Qualified Professional and accepted by the Development Engineer.

“Contractor” means a person having a contract with a Developer or the City to construct Works and Services required by this Bylaw.

“Council” means the Council of the Corporation of the City of Courtenay.

“Developer” means the owner of land, or appointed agent for the owner, in respect of which a subdivision application or building permit application has been made.

“Development Engineer” means the person designated the Manager of the department responsible to approve subdivisions by the City of Courtenay, or a designate.

“Inspector” means a person who shall make inspections and tests, on behalf of the Developer, of any Works and Services being carried out to ensure compliance with this Bylaw.

“Master Municipal Construction Documents” or “MMCD” means the most recent version of the Platinum Edition documents of that name issued by the Master Municipal Construction Documents Association including any revisions issued by the Association, as of the date of application for a subdivision or building permit referred to in Section 3 or Section 5 of this bylaw, respectively, which documents are incorporated into and form part of this bylaw.

“Qualified Professional” means a Professional Engineer who is registered or licensed to practice in British Columbia under the provisions of the *Engineers and Geoscientists Act*, who is responsible for the design, construction, supervision and certification of all Works and Services on behalf of the Developer.

“Security” means cash or a clean, unconditional, irrevocable and automatically renewing letter of credit drawn on a chartered bank or credit union having a branch in the City at which demand may be made on the letter of credit.

“Servicing Agreement” means an agreement between the Developer and the City for the construction and installation of Works and Services required under this Bylaw and pursuant to the *Local Government Act*.

“Subdivide” or “Subdivision” means:

- (a) a *subdivision* as defined in the *Land Title Act* including the adjustment of existing parcel boundaries; or
- (b) a *subdivision* as defined in the *Strata Property Act*.

“Works and Services” means the works and services a Developer is required to provide under this Bylaw, including all design, construction, installation and certification.

2. All *Works and Services* shall be designed by a *Qualified Professional* in accordance to this Bylaw, and adhere to all other *City* Bylaws, Provincial and Federal Regulations.
3. No person shall *subdivide* land in the *City* unless:
  - (a) the *Works and Services* required by this bylaw have been provided by the *Developer* to the satisfaction of the *Development Engineer*; or
  - (b) the *Developer* has entered into an agreement with the *City* to *construct* and install the required *Works and Services* by a date specified in the agreement, and provided to the *City* *security* in the amount determined by the *Development Engineer*, having regard to the cost of installing and paying for the *Works and Services*.

4. Section 3 does not apply:
  - (a) in relation to underground wiring, conduit and vaults, in the case of any *subdivision* resulting in the creation of fewer than 2 additional parcels in an area zoned for single-family residential use only, where the electrical and telephone services abutting the parcel being subdivided and all immediately abutting parcels are above-ground; or
  - (b) in relation to *Works and Services* of any type, in cases where the *Development Engineer* determines that the need for the *Works or Services* is not directly attributable to the *subdivision*, or to buildings likely to be constructed in the *subdivision*.
5. No person shall *construct* a building or structure in the *City* for which a building permit is required unless:
  - (a) the *Works and Services* required by this bylaw have been constructed by the *Developer* to the satisfaction of the *Development Engineer*; or
  - (b) the *Developer* has entered into an agreement with the *City* to *construct* and install the required *Works and Services* by a date specified in the agreement, and provided to the *City security* in the amount determined by the *Development Engineer*, having regard to the cost of installing and paying for the *Works and Services*.
6. Section 5 does not apply:
  - (a) in relation to a building permit authorizing the construction of a single family dwelling whether or not the dwelling contains a secondary suite, or in relation to the construction of a two-family dwelling; or
  - (b) in relation to *Works and Services* of any type, in cases where the *Development Engineer* determines that the need for the *Works and Services* is not directly attributable to the building for which a building permit application has been made.
7. The *Development Engineer* may:
  - (a) from time to time, prescribe the form of *servicing agreement* referred to in sections 3 and 5, provided that each such agreement shall require the *Developer* to:
    - i. repair any deficiencies in design, materials or workmanship in the *Works and Services* that may arise during the Warranty Period following the completion of construction;

- ii. provide to the *City* throughout the construction period performance, *security* in the amount of up to 125 percent of the *construction costs* in relation to the construction of the *Works and Services*;
  - iii. pay all applicable fees and charges associated with the application, review, administration and compliance of the *Works and Services*;
  - iv. carry third party liability insurance in an amount and form acceptable to the *City*, naming the *City* as an additional insured, in respect of claims arising out of death, personal injury or damage arising from the construction of the *Works and Services*; and
  - v. indemnify the *City* and save it harmless in respect of all costs and expenses it may incur as a result of faulty workmanship or defective material in the *Works and Services*, in respect of which the *City* has provided notice to the *Developer* prior to the *City's* final acceptance of the *Works and Services*;
- (b) execute and deliver such agreements on behalf of the *City*, and
- (c) require that such agreements be drafted in a form that is registrable under s. 219 of the *Land Title Act* against title to the land being subdivided or built upon.

8. The *Works and Services* required by this bylaw are the following:

- (a) highways and lanes, boulevards including, without limitation, street trees, boulevard landscaping, irrigation, culverts, transit bays, sidewalks, walkways and pathways, cycling facilities, fences, bridges, retaining walls, curbs and gutters, traffic signs and signals, street lighting and conduit and vaults for underground wiring;
- (b) water distribution systems connected to the *City's* water distribution system including, without limitation, pipes, service connections, fire hydrant systems, valves and valve chambers, meters and meter chambers, pump stations and reservoirs;
- (c) sewage collection systems connected to the *City's* sewage collection system including, without limitation, pipes, service connections, inspection chambers, lift stations, manholes and sewage holding facilities; and
- (d) drainage collection systems connected to the *City's* drainage collection system including, without limitation, pipes, service connections, inspection chambers, catch basins, manholes, ditches, gates, stormwater retention and detention facilities, and environmental control facilities.

9. The *Works and Services* described in section 8 must, in all cases, be provided on that portion of any highway or lane immediately adjacent to the parcel that is the subject of the *subdivision* or building permit application, as the case may be, unless additional requirements are imposed under section 14.
10. The *Works and Services* required by sections 3 and 5 and under section 14 must be constructed and installed at the cost of the *Developer* to the standards set out in this Bylaw including its Schedules, and using only those materials and products as identified in the *City's* Approved Products List, as amended from time to time.
11. If *Works and Services* of the type described in section 8 are already in existence on or in the highway or lane adjacent to a parcel being subdivided or on which a building is proposed to be constructed, and the *Works and Services* do not comply with the standards specified in section 10, the *Developer* must alter the *Works and Services* so that they comply with the standards, and the provisions of sections 3 and 5 regarding agreements and *security* apply to the alterations.
12. The *Development Engineer* may require a *Developer* to pay to the *City*:
  - (a) In lieu of constructing or altering *Works and Services* required by this bylaw, cash in the amount determined by the *Development Engineer* to be the cost of constructing or altering the *Works and Services* as of the time of approval of the *subdivision* or issuance of the building permit, if the *Development Engineer* determines on the basis of sound civil engineering practice or cost considerations that the works should be constructed or altered at a later time or concurrently with the construction or alteration of *Works and Services* serving adjacent or nearby parcels of land, and in such cases the *City* shall deposit the funds into a reserve fund established for the construction or alteration of the *Works and Services*.
  - (b) In the case of boulevard trees required by this bylaw, the *Developer* must pay to the *City*, in lieu of installing the trees, cash in the amount determined by the *Development Engineer* as the cost to procure and install the trees, which the *City* shall deposit into a reserve fund established for the installation of boulevard trees and apply to the cost of installing the trees, maintenance and replacement if the tree does not survive, at such time following the completion of all construction associated with the *subdivision* or development as the *Development Engineer* may determine. The *Developer* shall have no further obligations under this bylaw in respect of such boulevard trees after providing the cash payment required by the *Development Engineer*.
13. The *Works and Services* required by this bylaw shall be provided in dedicated highways, unless the *Development Engineer* has approved the location of the *Works and Services* in a statutory right of way granted to the *City*, in which case the statutory right of way,

including any required plan of right of way, must be prepared at the cost of the *Developer*, in terms satisfactory to the *Development Engineer* and the *City Solicitor*, and deposited concurrently with the deposit of the *subdivision* plan in the case of a *subdivision* application and prior to the issuance of an occupancy permit in the case of a building permit application.

14. Any *Works and Services* required by this bylaw within an existing highway right-of-way shall be provided, at a minimum, to the centre line of the highway along the entire frontage of the property, except that all required utility upgrades for water, sanitary sewer, stormwater, natural gas, electrical, street lighting or telecommunications shall be provided within the entire right-of-way regardless of its location.
15. The *Council* delegates to the *Development Engineer* the powers of the *Council* under the *Local Government Act* to:
  - (a) require a *Developer* to *construct* excess or extended services as defined in Sections 507 of the *Local Government Act* other than any excess or extended services that are required by this bylaw in respect of all *subdivision* and building permit applications;
  - (b) determine whether the cost to the *City* to provide the excess or extended services would be excessive and, in that event, that the cost must be paid by the *Developer*;
  - (c) determine the benefit of the excess or extended service that may be attributed to each of the parcels of land that will be served by the services; and
  - (d) impose latecomer charges under Section 508 of the *Local Government Act* including interest at a rate determined by the *City* and established in the *City of Courtenay Fees and Charges Bylaw No. 1673, 1992 as amended*.
16. For the purpose of section 15, the *Development Engineer* may require the *Developer's Qualified Professional* to provide information specifying parcels of land that will be served by the excess or extended services and the benefit that each such parcel derives from the services, and execute and deliver on behalf of the *City* agreements with *Developers* regarding the collection and remittance of latecomer charges, which agreements may be combined with *Works and Services* agreements as referred to in sections 3 and 5.
17. All *Works and Services* shall be completed in accordance with the following portions of the *Master Municipal Construction Documents*, unless specifically modified herein.
  - (a) Volume II Master Municipal Specifications – Division 01, 03, 06, and 31 to 34 inclusive including any relevant definitions in the Master Municipal General Conditions and excluding all provisions pertaining to measurement and payment;









# SUBDIVISION AND DEVELOPMENT SERVICING BYLAW 2919

MARCH 5, 2018

**SCHEDULE 1**  
**SUPPLEMENTARY DESIGN GUIDELINES**

## **SUPPLEMENTARY DESIGN GUIDELINES**

This schedule contains supplementary design guidelines to be applied in conjunction with the Design Guideline Manual of the Master Municipal Construction Documents, dated 2014, both of which shall apply to all Works and Services constructed within the City of Courtenay.

Supplementary Design Guidelines contained within this Schedule supplement or supersede the Master Municipal Construction Document (MMCD). Where the City of Courtenay Supplementary Design Guidelines are in conflict with the MMCD, the City of Courtenay Supplementary Design Guidelines shall take precedence.

Section number and clause numbers in the City of Courtenay Supplementary Design Guidelines coincide with the MMCD numbering protocol.

### **TABLE OF CONTENTS**

#### **SECTION**

#### **1.0 GENERAL DESIGN CONSIDERATIONS**

##### **1.2 INDEPENDENT UTILITIES**

#### **2.0 WATER DISTRIBUTION**

##### **2.2 METERING**

##### **2.3 PER CAPITA DEMAND**

##### **2.8 HYDRAULIC DESIGN**

##### **2.9 MINIMUM PIPE DIAMETER**

##### **2.14 VALVES**

##### **2.15 HYDRANTS**

##### **2.18 AIR VALVES**

##### **2.21 SERVICE CONNECTIONS**

##### **2.25 PRESSURE REDUCING VALVE (PRV) STATIONS**

##### **2.25.2 DESIGN FEATURES**

#### **3.0 SANITARY SEWERS**

##### **3.2 PER CAPITA FLOW**

##### **3.8 FLOW VELOCITIES**

##### **3.10 MINIMUM PIPE DIAMETER**

##### **3.12 CURVED SEWERS**

##### **3.14.1 LOCATIONS**

##### **3.16.3 GRADE**

##### **3.16.4 DETAILS**

##### **3.18 PUMP STATIONS**

#### **4.0 STORMWATER MANAGEMENT**

##### **4.1.1 DRAINAGE PLANNING**

##### **4.1.2 MASTER DRAINAGE PLAN**

##### **4.3.1 THE MINOR SYSTEM**

- 4.3.2 THE MAJOR SYSTEM
- 4.3.3 STORMWATER DETENTION RELEASE RATES
- 4.4 RUNOFF ANALYSIS
- 4.9.6 MINIMUM PIPE DIAMETER
- 4.9.8 CURVED SEWERS
- 4.9.10 PIPE JOINTS
- 4.9.14 SERVICE CONNECTIONS
- 4.10.3 SURFACE FLOW CAPACITY
- 4.11.2 UNDERGROUND STORAGE
- 4.11.3 DRY DETENTION PONDS
- 4.11.4 WET DETENTION PONDS
- 4.11.5 SUBSURFACE DISPOSAL/INFILTRATION SYSTEMS
- 4.11.8 OIL AND GRIT SEPARATORS
- 4.11.10 ALTERNATE DESIGN STANDARDS
- 4.12 EROSION AND SEDIMENT CONTROL (ESC)

## 5.0 ROADS

- 5.3 CROSS-SECTION ELEMENTS
- 5.4.2 VERTICAL CURVES
- 5.7 RAILWAY GRADE CROSSINGS
- 5.8 TRAFFIC CONTROL DEVICES
- 5.9 CULS-DE-SAC
- 5.9.1 TEMPORARY TURNAROUND
- 5.10.1 TRAFFIC BARRIERS AT TEMPORARY CUL-DE-SAC AND TURNAROUNDS
- 5.11.1 SIDEWALK
- 5.11.2 PEDESTRIAN CROSSINGS
- 5.14.4 DRIVEWAY GRADES
- 5.14.8 DRIVEWAY SURFACE
- 5.15.3 SIGNS AND POLES
- 5.15.4 TREES
- 5.16 UNDERGROUND UTILITY LOCATIONS
- 5.17.3 PAVEMENT ALTERNATIVES
- 5.21 STREET PARKING
- 5.22 RETAINING WALLS

## 6.0 ROADWAY LIGHTING

- 6.1 GENERAL
- 6.2.2 STANDARDS AND GUIDELINES
- 6.5.1 LIGHT SOURCES AND LUMINAIRES
- 6.7 SIDEWALK LIGHTING
- 6.8 INTERSECTION LIGHTING
- 6.9 CROSSWALK LIGHTING
- 6.13 POLES
- 6.14 POLE FOUNDATIONS
- 6.15 LUMINAIRES
- 6.16 POWER SUPPLY AND DISTRIBUTION
- 6.17.4 DRAWING REQUIREMENTS

## 7.0 TRAFFIC SIGNALS

- 7.3.1 CODES, RULES AND REGULATIONS
- 7.4 SIGNAL HEADS
- 7.8 SIGNAL PRE-EMPTION
- 7.9 AUDIBLE PEDESTRIAN SIGNALS
- 7.11 DETECTION METHODS
- 7.15 POLES AND FOUNDATIONS
- 7.18 POWER SUPPLY AND DISTRIBUTION
- 7.19 UNINTERRUPTIBLE POWER SUPPLIES (UPS'S)
- 7.21 DRAWING REQUIREMENTS

**SUPPLEMENTARY DESIGN GUIDELINES  
GENERAL DESIGN CONSIDERATIONS**



**1.0 GENERAL DESIGN CONSIDERATIONS**

- |                                  |                   |  |
|----------------------------------|-------------------|--|
| <b>1.2 Independent Utilities</b> | Add Section 1.2.1 | Design for location and relocation of Canada Post Mailbox shall be coordinated with Canada Post. |
|----------------------------------|-------------------|--|

**SUPPLEMENTARY DESIGN GUIDELINES  
WATER DISTRIBUTION**





**2.0 WATER DISTRIBUTION**

**2.2 Metering**

Replace Section

For all single family residential homes without fire sprinklers the water meter setter size shall be 25mm except in the case where there is a demonstrated need for a larger meter. All other meters must be sized in accordance with AWWA M22 and form contained in Appendix A. It should be noted that this methodology is based on the fixture value method and not the fixture unit method employed in the BC Building Code for piping within buildings.

The maximum operating range for a water meter shall be less than 80% of the maximum instantaneous flow capacity as outlined by the meter manufacturer, with a maximum pressure loss of 48 kPa at the design flow rate. The size selection must not compromise the operating range or the long term life of the meter and must ensure that pressures supplied to property are appropriate for the intended use.

For developments that are proposed to be phased, the meter chamber and piping must be sized for the meter required for the ultimate buildout of the development. However, the initial meter installed must also be sized to accurately capture the range of flows for the first phase.

The Qualified Professional must ensure the meter selection and installation requirements are appropriate for the designed application.

A Qualified Professional must provide detailed sealed drawings and shop drawings of the installation and relevant calculations, to demonstrate the appropriateness of the sizing of the meter, for approval prior to installing the chamber.

**2.3 Per Capita Demand**

Replace Section

In the absence of reliable water consumption records, the following per capita demands shall be applied to future residential development:

- ADD: 635 L/c/d
- Peak Day: 2100 L/c/d
- Peak Hour: 3000 L/c/d



|             |                              |                 |   |
|-------------|------------------------------|-----------------|---|
| <b>2.9</b>  | <b>Minimum Pipe Diameter</b> | Delete          | Service Connections: 19mm   |
|             |                              | Replace with    | Service Connections: 25mm   |
| <b>2.14</b> | <b>Valves</b>                | Delete          | <ul style="list-style-type: none"> <li>The valves shall be the same diameter as the watermain up to 300mm diameter</li> <li>The main line valves on mains 350 mm and 400 mm diameter may be smaller by one (10 size with the use of proper reducers</li> <li>The main line valves on mains 450 mm diameter and larger may be smaller by two (2) sizes with the use of proper reducers</li> </ul>  |
|             |                              | Replace with    | <ul style="list-style-type: none"> <li>The main line valves on mains of all sizes shall be of the same nominal diameter as the watermain.</li> </ul>  |
| <b>2.15</b> | <b>Hydrants</b>              | Add Bullet      | <ul style="list-style-type: none"> <li>STORZ connection must face the road or cul-de-sac at 90 degrees.</li> </ul>  |
| <b>2.18</b> | <b>Air Valves</b>            | Replace Section | <p>Combination air valves must be installed at the summits of all mains of 200 mm diameter and larger, except as follows:</p> <ul style="list-style-type: none"> <li>Where the difference in elevation between the summit and valley is less than 600 mm.</li> <li>Where it can be shown that air pockets will be carried by typical flows.</li> <li>Where active service connections are suitably located to dissipate trapped air.</li> </ul> |

Typical air valve sizes, subject to design analysis, are as follows (Table 2.18)

**Table 2.18 Typical Air Valve sizes**

| Watermain Size     | Valve Size     |
|--------------------|----------------|
| 200 mm to 300 mm   | 25 mm          |
| 350 mm to 600 mm   | 50 mm          |
| Larger than 600 mm | Special Design |

Air Valves located in a flood plain shall be of a manual permanent blow type

|             |                            |                |  |
|-------------|----------------------------|----------------|--|
| <b>2.21</b> | <b>Service Connections</b> | Add to Section | Every legal lot and each unit of residential duplex must be provided with a separate service connection. |
|-------------|----------------------------|----------------|--|



**2.25.2 Design Features**      Replace Section

General requirements for pressure reducing stations shall be as follows:

- Include a dual Pressure Reduction Valve (PRV) arrangement with separate domestic and fire flow PRV's.
  - Epoxy coated valve bodies both inside and out.
  - Fire flow PRV must be equipped with a position indicator (limit switch).
  - Domestic flow PRV must be equipped with position indicator and insertion flow meter.
  - Filters shall be provided on all valve control piping.
  - All piloting shall be set to fail close.
- Include a surge/high pressure relief valve with stainless steel mesh dechlorination basket (capable of housing a minimum of 8 – 65mm dechlorination pucks).
- Pressure relief valves and surge relief valves to include anti-cavitation trim where recommended by the manufacturer based on site specific differential pressures.
- Each PRV and surge relief valve must be provided with isolating valves such that individual components can be removed for repair and each component can be operated independently.
- Pressure gauges and pressure transducers complete with snubbers and isolating valves must be included to register both upstream and downstream pressure.
- All piping and fittings, including control piping, must be stainless steel;
- Grooved couplings must be included to assist in disassembly of piping as required.
- All equipment and controls must be mounted in an above ground secure, lockable cabinet, on a concrete foundation. The cabinet shall be as follows:
  - Include two separate compartments, including one for the electrical controls and another for the mechanical piping and valves. All compartments must be heated, lighted and the controls enclosure must be ventilated.
  - Include removable roof hatch above the Mechanical compartment.



- Fabricated from powder coated aluminum.
- Include a rubber gasket between the aluminum kiosk and the concrete to prevent water leakage into the kiosk.
- The PRV station include 8 hours of uninterruptible power (UPS) and a user control interface (HMI).
- The PRV station must be integrated with the City's SCADA system via ethernet or cellular telephone connection to monitor at a minimum:
  - PRV valve position.
  - Utility failure.
  - Access intrusion.
  - Limits switches.
  - High pressure relief.
  - Flow data.

**SUPPLEMENTARY DESIGN GUIDELINES  
SANITARY SEWERS**



### 3.0 SANITARY SEWERS

|                                   |                            |  |
|-----------------------------------|----------------------------|--|
| <b>3.2 Per Capita Flow</b>        | Replace Section            | In the absence of sanitary sewer flow records, sanitary sewer system design should be based on an average daily dry weather flow (ADWF) of 360 litres per day per capita (L/d/c).  |
| <b>3.8 Flow Velocities</b>        | Delete<br><br>Replace with | <ul style="list-style-type: none"><li>▪ Force mains: 0.75 m/s</li><br/><li>▪ Force mains: 0.9 m/s</li></ul>  |
| <b>3.10 Minimum Pipe Diameter</b> | Replace Section            | <p>The minimum pipe diameter is 200mm.</p> <p>Sewers must be designed to satisfy the following parameters:</p> <ul style="list-style-type: none"><li>▪ 200mm diameter and less: <math>d/D &lt; 0.5</math>.</li><li>▪ 250mm diameter: <math>d/D &lt; 0.7</math>.</li><li>▪ 300mm diameter and greater: <math>d/D &lt; 0.8</math>.</li></ul>   |
| <b>3.12 Curved Sewers</b>         | Replace Section            | <p>On curving roads, sanitary sewers shall be installed in straight runs such that sewer mains and manholes are entirely under the road pavement and no closer than 1m to the curb. Curvilinear sewers are permitted on horizontal curves and shall have a constant offset from property line. The radius of curve shall not exceed 50% of the manufacturer's recommended maximum and shall not be less than 60m. The minimum grade shall be 1% and each joint shall be located by survey. Manholes are to be installed at the beginning and end of horizontal curve sections.</p> <p>The minimum design velocity design velocity in curved sewers is 0.9 m/s.</p> |
| <b>3.14.1 Locations</b>           | Replace Section            | <p>Manholes are required at the following locations:</p> <ul style="list-style-type: none"><li>▪ Every change of pipe size.</li><li>▪ Every change in grade.</li><li>▪ Every change in direction.</li><li>▪ Every pipe intersection except for 100 mm and 150 mm service connections and junctions with trunk sewers 900 mm diameter and larger.</li><li>▪ Every future pipe intersection.</li></ul>   |



- 150 m maximum spacing for pipe diameters up to 450 mm.
- 300 m maximum spacing for pipe diameter of 450 mm and larger.
- Every beginning and end of horizontal curves.

**3.14.2 Hydraulic Details**      Replace Table 3.14

**Table 3.14 Drop Structures**

| Invert Difference                         | Structure     |
|---|---------------|
| Up to 0.25 m                              | Inside Ramp   |
| 0.25 to 0.90 m                            | Outside Ramp  |
| Greater than 0.90 m                       | Outside Drop* |
| *Inside drop structures are not permitted |               |

Delete Sentence      If a manhole drop cannot be avoided, an inside drop pipe is required.

**3.16.3 Grade**      Delete

- 100 mm diameter pipe: 1.50%

Replace with

- 100mm diameter pipe: 2% min.

**3.16.4 Details**      Replace Section

Use standard wye fittings for connections to new mains. For connections to existing mains, use strap on saddle. No other saddles will be permitted. The service connection centreline must not be below the sewer main centreline.

Residential service connections are not to be connected to manholes. All wye connections to be a minimum of 1.0 m downstream from manhole.

Inspection chambers are required on residential connections. Control manholes are required on industrial connections and commercial connections. Inspection manholes are required on service connections 200mm diameter and larger. Connections exceeding 30 m in length will be treated as mains.

**3.18 Pump Stations**      Replace Section

Replace this section with the document “Standards for Sanitary Lift Stations”, provided in Schedule 4.

**SUPPLEMENTARY DESIGN GUIDELINES  
STORMWATER MANAGEMENT**





## 4.0 STORMWATER MANAGEMENT

- 4.1.1 Drainage Planning** Add Section 4.1.1 The Developer shall prepare such plans prior to approval of the development applications. Such plans shall provide an in-depth review of stormwater opportunities and constraints on a specific watershed, and take into consideration the potential impacts and remediation measures for the affected watercourses.
- Submission requirements for Developers are in accordance with 2014 MMCD Design Guideline Manual Stormwater Management Section 4.2: Stormwater Control Plan.
- 4.1.2 Master Drainage Plan** Add Section 4.1.2 The Master Drainage Plan (MDP), Watershed Plan (WP) or Integrated Stormwater Management Plan (ISMP) proposes an optimum drainage servicing strategy that meets the ultimate land use in the watershed. The proposed MDP must address all identified constraints and provide the following information as required:
- Conceptual schemes for storm drainage servicing including trunk storm sewers, catchment detention ponds, minor and major flow routes, and erosion protection.
  - Department of Fisheries & Oceans and BC Ministry of Forests, Lands, Natural Resource Operations and & Rural Development review.
  - Hydrological and hydraulic model of pre-development and ultimate development condition.
  - Bio-inventory of creeks and watercourses.
  - Hydrogeological Impact Assessment (in areas where DFO and MOE jointly require its consideration).
  - Inventory of watercourses and trunk drainage facilities.
  - Sizes and performance requirements of catchment detention facilities.
  - Priority of MDP recommendations.
- 4.3.1 The Minor System** Replace Section Consists of pipes, gutters, catch basins, driveway culverts, open channels, watercourses and stormwater management “best management practices” (BMPs) designed to capture, convey, treat



or modify flows up to and including the 1 in 10 year return period storm event.

**4.3.2 The Major System**

Replace Section

Consists of surface flow paths, roadways culverts, watercourses, and stormwater management facilities designed to capture, convey, treat or modify larger flows up to and including the 1 in 100 year return period storm event.

If required to accommodate low building elevations, and if approved, a piped minor system may be enlarged or supplemented to accommodate major flows.

**4.3.3 Stormwater Detention Release Rates**

Add Section 4.3.3

All stormwater detention facilities shall be designed to limit post-development peak flows to equal to the corresponding pre-development peak flows for the 1 in 2, 1 in 5, 1 in 10 and 1 in 25 year return period storm events. Overland escape routes must be provided to account for greater storms up to 1 in 100 year return period in a manner which does not result in flooding of any properties. Design rainfall intensities have been increased by 15% as indicated in Section 4.4.

The total volume of runoff generated during storms can also have a significant impact on receiving watercourses. To the extent possible, the total runoff generated from storms should be minimized through the application of site adaptive planning and the use of source controls. Site adaptive planning focuses on limiting total imperviousness at development sites and preserving natural features such as wetlands, forests and native soils. Source controls focus on reducing volume by retaining or enhancing opportunities for infiltration and evapotranspiration on development sites.

Discharge shall be controlled such that the downstream watercourses receiving outflow from detention facilities are protected from surcharge and erosion. Where stability cannot be maintained, measures to avoid or mitigate erosion shall be proposed.

**4.4 Runoff Analysis**

Delete Bullet

- Hydrograph Method: Applicable for all areas larger than 10 hectares, more hydrologically complex catchments, and where stormwater



management systems require more than basic conveyances. The computer program proposed for use is subject to approval by the local authority. The program should be selected to suit the complexity of the watershed and the hydrologic processes that need to be considered (e.g. detention, groundwater recharge and infiltration, evapotranspiration, continuous simulation, etc.) The most widely used programs (or software packages) are those that are SWMM based, however are constantly evolving, it is inappropriate for this guide document to state or endorse any particular ones.

Replace with

- Hydrograph Method: Applicable for complex systems involving multiple catchments with highly variable land use conditions, where flow attenuation features are involved (eg. detention pond, constructed wetland), or for gross areas exceeding 10 hectares. Computer models shall be based on the U.S. Environmental Protection Agency’s SWMM software.

Add Bullet

- Mass Balance: Volumetric based computations may be used to supplement flow analysis for the design of water quality treatment BMPs and BMPs intended for stormwater detention.

Add to Section

Computer stormwater models shall utilize the 10 and 100 year return period design storm hyetographs provided in Table 4.4.2. These hyetographs have been derived using the Modified Chicago Distribution for a 24 hour storm duration. The hyetographs have also been adjusted to reflect a 15% increase in rainfall intensities.

**Note:** Performance of the drainage systems may be under the influence of ocean levels and pump stations, and therefore may surcharge under certain conditions. Aside from the runoff analysis method applied, hydraulic grade lines shall be indicated in design drawings and associated system performance shall consider governing downstream hydraulic boundary conditions.



**Figure 4.4: Intensity Duration Frequency Curves – Courtenay Puntledge BCHP ID: 1021990  
15% Increase from Historical Intensities (mm/hr)**

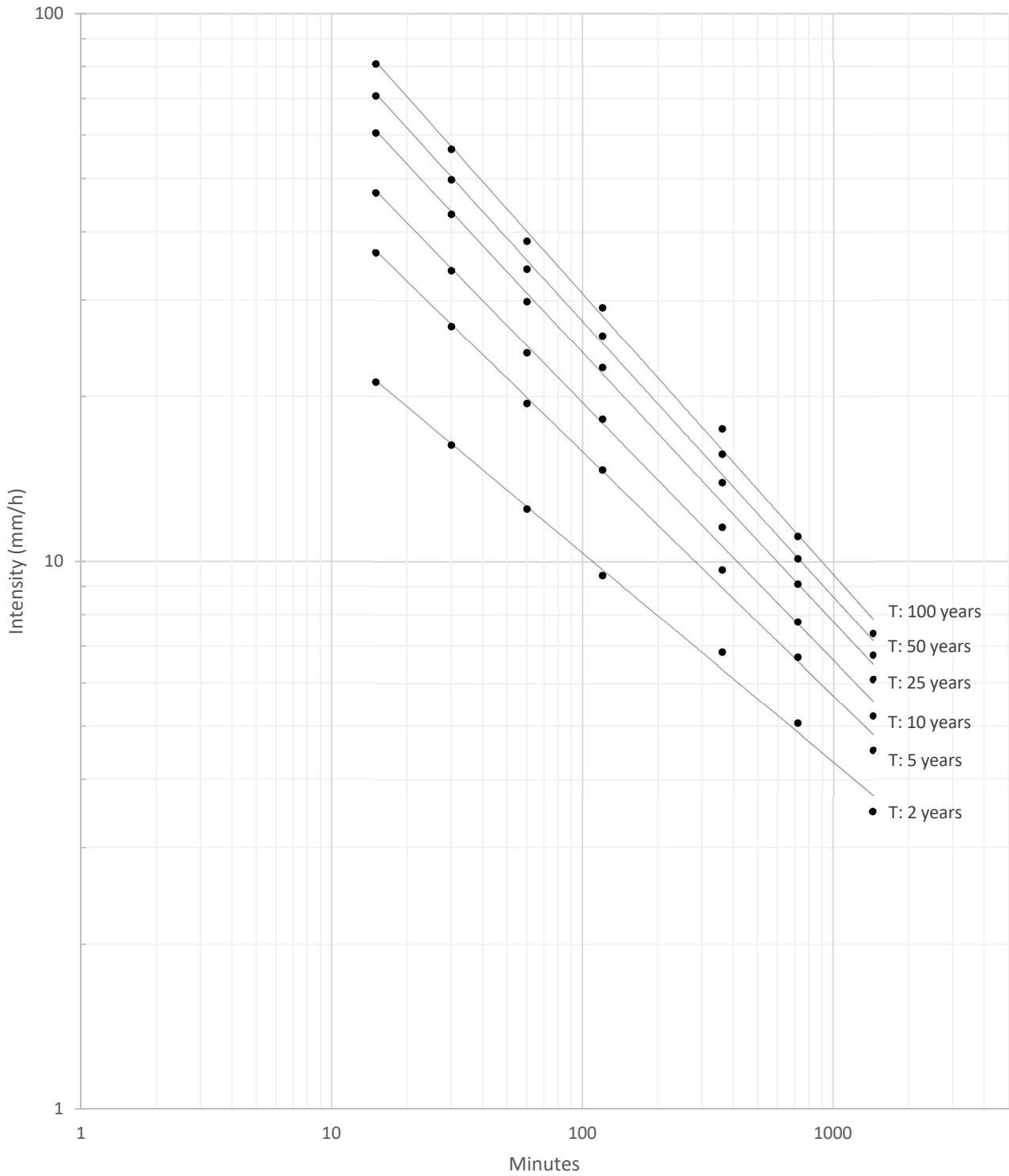



**Table 4.4.1: IDF Curve Intensity Table Summary  
15% Increase from Historical Intensities (mm/hr)**

| Time    |       | Return Frequency |      |       |       |       |        |
|---------|-------|------------------|------|-------|-------|-------|--------|
| Minutes | Hours | 2 yr             | 5 yr | 10 yr | 25 yr | 50 yr | 100 yr |
| 15      | 0.25  | 21.3             | 36.7 | 47.2  | 60.7  | 70.8  | 80.9   |
| 30      | 0.5   | 16.3             | 26.9 | 34.1  | 43.1  | 49.9  | 56.7   |
| 60      | 1     | 12.5             | 19.5 | 24.1  | 29.9  | 34.3  | 38.6   |
| 120     | 2     | 9.5              | 14.7 | 18.2  | 22.6  | 25.9  | 29.1   |
| 360     | 6     | 6.8              | 9.7  | 11.6  | 14.0  | 15.7  | 17.5   |
| 720     | 12    | 5.1              | 6.7  | 7.8   | 9.1   | 10.1  | 11.1   |
| 1440    | 24    | 3.5              | 4.5  | 5.2   | 6.1   | 6.8   | 7.4    |

Note: 15 and 30 minute durations have been extrapolated from historical IDF Curve

**Table 4.4.2: Interpolation Equation of IDF Curve – Historical Data**  
 **$R = A * T^B$  where: R = Rainfall (mm/hr), A and B = Coefficients, based on return period**

| Parameters | Return Frequency |        |        |        |        |        |
|------------|------------------|--------|--------|--------|--------|--------|
|            | 2 yr             | 5 yr   | 10 yr  | 25 yr  | 50 yr  | 100 yr |
| <b>A</b>   | 11.0             | 17.5   | 21.9   | 27.3   | 31.4   | 35.5   |
| <b>B</b>   | -0.386           | -0.452 | -0.477 | -0.499 | -0.511 | -0.521 |

Note: Coefficients are based on Historical Data - 15% must be added to resulting intensities



**Table 4.4.3: Modified Chicago Distribution – 24 Hr Design Storm Data (10 Minute Increment)  
15% Increase from Historical Intensities (mm/hr)  
Years of Record: 1964-1995 (35 Years)**

| Time (min) | Return Frequency |        |         |         |          |
|------------|------------------|--------|---------|---------|----------|
|            | 2 year           | 5 year | 10 year | 25 Year | 100 year |
| 0          | 2.29             | 2.64   | 2.91    | 3.24    | 3.76     |
| 10         | 2.31             | 2.66   | 2.94    | 3.28    | 3.80     |
| 20         | 2.33             | 2.69   | 2.98    | 3.32    | 3.85     |
| 30         | 2.35             | 2.72   | 3.01    | 3.36    | 3.90     |
| 40         | 2.38             | 2.76   | 3.05    | 3.40    | 3.95     |
| 50         | 2.40             | 2.79   | 3.09    | 3.45    | 4.01     |
| 60         | 2.43             | 2.82   | 3.13    | 3.49    | 4.07     |
| 70         | 2.45             | 2.86   | 3.17    | 3.54    | 4.12     |
| 80         | 2.48             | 2.90   | 3.21    | 3.59    | 4.19     |
| 90         | 2.51             | 2.93   | 3.26    | 3.65    | 4.25     |
| 100        | 2.54             | 2.97   | 3.30    | 3.70    | 4.32     |
| 110        | 2.57             | 3.02   | 3.35    | 3.76    | 4.39     |
| 120        | 2.60             | 3.06   | 3.40    | 3.82    | 4.46     |
| 130        | 2.63             | 3.11   | 3.46    | 3.88    | 4.54     |
| 140        | 2.67             | 3.15   | 3.52    | 3.95    | 4.62     |
| 150        | 2.70             | 3.21   | 3.58    | 4.02    | 4.71     |
| 160        | 2.74             | 3.26   | 3.64    | 4.10    | 4.80     |
| 170        | 2.78             | 3.32   | 3.71    | 4.17    | 4.89     |
| 180        | 2.83             | 3.38   | 3.78    | 4.26    | 5.00     |
| 190        | 2.87             | 3.44   | 3.85    | 4.35    | 5.11     |
| 200        | 2.92             | 3.51   | 3.93    | 4.44    | 5.22     |
| 210        | 2.97             | 3.58   | 4.02    | 4.54    | 5.35     |
| 220        | 3.03             | 3.66   | 4.11    | 4.65    | 5.48     |
| 230        | 3.08             | 3.74   | 4.21    | 4.77    | 5.62     |
| 240        | 3.15             | 3.83   | 4.31    | 4.89    | 5.78     |
| 250        | 3.21             | 3.92   | 4.43    | 5.03    | 5.94     |
| 260        | 3.29             | 4.03   | 4.55    | 5.18    | 6.13     |
| 270        | 3.37             | 4.14   | 4.69    | 5.34    | 6.33     |
| 280        | 3.45             | 4.27   | 4.84    | 5.52    | 6.55     |
| 290        | 3.55             | 4.41   | 5.00    | 5.71    | 6.79     |
| 300        | 3.65             | 4.56   | 5.19    | 5.93    | 7.07     |
| 310        | 3.77             | 4.73   | 5.39    | 6.18    | 7.38     |
| 320        | 3.90             | 4.93   | 5.63    | 6.46    | 7.73     |
| 330        | 4.05             | 5.15   | 5.90    | 6.79    | 8.13     |
| 340        | 4.23             | 5.41   | 6.21    | 7.17    | 8.61     |
| 350        | 4.43             | 5.72   | 6.59    | 7.62    | 9.18     |
| 360        | 4.68             | 6.09   | 7.04    | 8.17    | 9.87     |
| 370        | 4.98             | 6.56   | 7.61    | 8.86    | 10.74    |
| 380        | 5.37             | 7.16   | 8.34    | 9.76    | 11.88    |
| 390        | 5.89             | 7.98   | 9.36    | 11.00   | 13.47    |
| 400        | 6.66             | 9.22   | 10.90   | 12.90   | 15.90    |
| 410        | 8.00             | 11.43  | 13.68   | 16.37   | 20.39    |
| 420        | 11.84            | 18.14  | 22.30   | 27.33   | 34.86    |
| 430        | 25.10            | 44.93  | 58.80   | 76.25   | 103.14   |
| 440        | 12.39            | 19.06  | 23.47   | 28.80   | 36.78    |
| 450        | 9.84             | 14.55  | 17.65   | 21.37   | 26.93    |
| 460        | 8.54             | 12.33  | 14.82   | 17.79   | 22.24    |
| 470        | 7.71             | 10.93  | 13.05   | 15.57   | 19.35    |
| 480        | 7.11             | 9.94   | 11.80   | 14.02   | 17.34    |

| Time (min) | Return Frequency |        |         |         |          |
|------------|------------------|--------|---------|---------|----------|
|            | 2 year           | 5 year | 10 year | 25 Year | 100 year |
| 490        | 6.65             | 9.19   | 10.86   | 12.86   | 15.84    |
| 500        | 6.28             | 8.60   | 10.12   | 11.94   | 14.67    |
| 510        | 5.97             | 8.11   | 9.52    | 11.20   | 13.72    |
| 520        | 5.72             | 7.70   | 9.02    | 10.58   | 12.93    |
| 530        | 5.49             | 7.35   | 8.59    | 10.06   | 12.26    |
| 540        | 5.30             | 7.05   | 8.22    | 9.60    | 11.68    |
| 550        | 5.13             | 6.79   | 7.89    | 9.20    | 11.17    |
| 560        | 4.98             | 6.55   | 7.60    | 8.85    | 10.73    |
| 570        | 4.84             | 6.34   | 7.34    | 8.54    | 10.33    |
| 580        | 4.72             | 6.15   | 7.11    | 8.25    | 9.97     |
| 590        | 4.60             | 5.98   | 6.90    | 8.00    | 9.65     |
| 600        | 4.50             | 5.82   | 6.71    | 7.76    | 9.35     |
| 610        | 4.40             | 5.67   | 6.53    | 7.55    | 9.08     |
| 620        | 4.31             | 5.54   | 6.36    | 7.35    | 8.84     |
| 630        | 4.23             | 5.41   | 6.21    | 7.17    | 8.61     |
| 640        | 4.15             | 5.29   | 6.07    | 7.00    | 8.39     |
| 650        | 4.08             | 5.19   | 5.94    | 6.84    | 8.19     |
| 660        | 4.01             | 5.08   | 5.82    | 6.69    | 8.01     |
| 670        | 3.94             | 4.99   | 5.70    | 6.55    | 7.84     |
| 680        | 3.88             | 4.90   | 5.59    | 6.42    | 7.67     |
| 690        | 3.83             | 4.81   | 5.49    | 6.30    | 7.52     |
| 700        | 3.77             | 4.73   | 5.39    | 6.18    | 7.37     |
| 710        | 3.72             | 4.66   | 5.30    | 6.07    | 7.24     |
| 720        | 3.67             | 4.58   | 5.22    | 5.97    | 7.11     |
| 730        | 3.62             | 4.51   | 5.13    | 5.87    | 6.99     |
| 740        | 3.58             | 4.45   | 5.05    | 5.77    | 6.87     |
| 750        | 3.53             | 4.39   | 4.98    | 5.68    | 6.76     |
| 760        | 3.49             | 4.33   | 4.91    | 5.60    | 6.65     |
| 770        | 3.45             | 4.27   | 4.84    | 5.52    | 6.55     |
| 780        | 3.42             | 4.21   | 4.77    | 5.44    | 6.45     |
| 790        | 3.38             | 4.16   | 4.71    | 5.36    | 6.36     |
| 800        | 3.34             | 4.11   | 4.65    | 5.29    | 6.27     |
| 810        | 3.31             | 4.06   | 4.59    | 5.22    | 6.18     |
| 820        | 3.28             | 4.01   | 4.53    | 5.15    | 6.10     |
| 830        | 3.25             | 3.97   | 4.48    | 5.09    | 6.02     |
| 840        | 3.21             | 3.92   | 4.43    | 5.03    | 5.94     |
| 850        | 3.18             | 3.88   | 4.38    | 4.97    | 5.87     |
| 860        | 3.16             | 3.84   | 4.33    | 4.91    | 5.80     |
| 870        | 3.13             | 3.80   | 4.28    | 4.85    | 5.73     |
| 880        | 3.10             | 3.76   | 4.24    | 4.80    | 5.66     |
| 890        | 3.08             | 3.73   | 4.19    | 4.75    | 5.60     |
| 900        | 3.05             | 3.69   | 4.15    | 4.70    | 5.54     |
| 910        | 3.03             | 3.66   | 4.11    | 4.65    | 5.48     |
| 920        | 3.00             | 3.62   | 4.07    | 4.60    | 5.42     |
| 930        | 2.98             | 3.59   | 4.03    | 4.56    | 5.36     |
| 940        | 2.96             | 3.56   | 3.99    | 4.51    | 5.31     |
| 950        | 2.93             | 3.53   | 3.96    | 4.47    | 5.26     |
| 960        | 2.91             | 3.50   | 3.92    | 4.43    | 5.20     |
| 970        | 2.89             | 3.47   | 3.89    | 4.39    | 5.15     |



| Time (min) | Return Frequency |        |         |         |          |
|------------|------------------|--------|---------|---------|----------|
|            | 2 year           | 5 year | 10 year | 25 Year | 100 year |
| 980        | 2.87             | 3.44   | 3.85    | 4.35    | 5.10     |
| 990        | 2.85             | 3.41   | 3.82    | 4.31    | 5.06     |
| 1000       | 2.83             | 3.38   | 3.79    | 4.27    | 5.01     |
| 1010       | 2.81             | 3.36   | 3.76    | 4.23    | 4.97     |
| 1020       | 2.80             | 3.33   | 3.73    | 4.20    | 4.92     |
| 1030       | 2.78             | 3.31   | 3.70    | 4.16    | 4.88     |
| 1040       | 2.76             | 3.28   | 3.67    | 4.13    | 4.84     |
| 1050       | 2.74             | 3.26   | 3.64    | 4.10    | 4.80     |
| 1060       | 2.73             | 3.24   | 3.61    | 4.06    | 4.76     |
| 1070       | 2.71             | 3.21   | 3.58    | 4.03    | 4.72     |
| 1080       | 2.69             | 3.19   | 3.56    | 4.00    | 4.68     |
| 1090       | 2.68             | 3.17   | 3.53    | 3.97    | 4.64     |
| 1100       | 2.66             | 3.15   | 3.51    | 3.94    | 4.61     |
| 1110       | 2.65             | 3.13   | 3.48    | 3.91    | 4.57     |
| 1120       | 2.63             | 3.11   | 3.46    | 3.88    | 4.54     |
| 1130       | 2.62             | 3.09   | 3.44    | 3.86    | 4.51     |
| 1140       | 2.60             | 3.07   | 3.41    | 3.83    | 4.47     |
| 1150       | 2.59             | 3.05   | 3.39    | 3.80    | 4.44     |
| 1160       | 2.58             | 3.03   | 3.37    | 3.78    | 4.41     |
| 1170       | 2.56             | 3.01   | 3.35    | 3.75    | 4.38     |
| 1180       | 2.55             | 2.99   | 3.32    | 3.73    | 4.35     |
| 1190       | 2.54             | 2.97   | 3.30    | 3.70    | 4.32     |
| 1200       | 2.52             | 2.96   | 3.28    | 3.68    | 4.29     |
| 1210       | 2.51             | 2.94   | 3.26    | 3.65    | 4.26     |
| 1220       | 2.50             | 2.92   | 3.24    | 3.63    | 4.23     |
| 1230       | 2.49             | 2.91   | 3.22    | 3.61    | 4.20     |
| 1240       | 2.47             | 2.89   | 3.21    | 3.59    | 4.18     |
| 1250       | 2.46             | 2.87   | 3.19    | 3.56    | 4.15     |
| 1260       | 2.45             | 2.86   | 3.17    | 3.54    | 4.12     |
| 1270       | 2.44             | 2.84   | 3.15    | 3.52    | 4.10     |
| 1280       | 2.43             | 2.83   | 3.13    | 3.50    | 4.07     |
| 1290       | 2.42             | 2.81   | 3.12    | 3.48    | 4.05     |
| 1300       | 2.41             | 2.80   | 3.10    | 3.46    | 4.03     |
| 1310       | 2.40             | 2.78   | 3.08    | 3.44    | 4.00     |
| 1320       | 2.39             | 2.77   | 3.06    | 3.42    | 3.98     |
| 1330       | 2.38             | 2.76   | 3.05    | 3.40    | 3.95     |
| 1340       | 2.37             | 2.74   | 3.03    | 3.38    | 3.93     |
| 1350       | 2.36             | 2.73   | 3.02    | 3.37    | 3.91     |
| 1360       | 2.35             | 2.72   | 3.00    | 3.35    | 3.89     |
| 1370       | 2.34             | 2.70   | 2.99    | 3.33    | 3.87     |
| 1380       | 2.33             | 2.69   | 2.97    | 3.31    | 3.84     |
| 1390       | 2.32             | 2.68   | 2.96    | 3.29    | 3.82     |
| 1400       | 2.31             | 2.66   | 2.94    | 3.28    | 3.80     |
| 1410       | 2.30             | 2.65   | 2.93    | 3.26    | 3.78     |
| 1420       | 2.29             | 2.64   | 2.91    | 3.25    | 3.76     |
| 1430       | 2.28             | 2.63   | 2.90    | 3.23    | 3.74     |
| 1440       | 0.00             | 0.00   | 0.00    | 0.00    | 0.00     |



|                                    |                 |                        |        |
|------------------------------------|-----------------|------------------------|--------|
| <b>4.9.6 Minimum Pipe Diameter</b> | Replace Section | ▪ Storm Sewer          | 250 mm |
|                                    |                 | ▪ Culvert:             |        |
|                                    |                 | -Crossing Roads        | 450 mm |
|                                    |                 | -Crossing Driveways    | 300 mm |
|                                    |                 | ▪ Catch Basin Leads    | 200 mm |
|                                    |                 | ▪ Service Connections: |        |
| -Residential                       | 150 mm          |                        |        |
| -Commercial/industrial             | 150 mm          |                        |        |

Downstream pipe sizes are not to be reduced unless the downstream pipe is 600 mm diameter or larger and increased grade provides adequate capacity. Detailed hydraulic analysis is required. That maximum reduction is two pipe sizes.

|                            |                 |  |
|----------------------------|-----------------|--|
| <b>4.9.8 Curved Sewers</b> | Replace Section | On curving roads, storm sewers shall be installed in straight runs such that sewer mains and manholes are entirely under the road pavement and no closer than 1m to the curb. Curvilinear sewers are permitted on horizontal curves and shall have a constant offset from property line. The radius of curve shall not exceed 50% of the manufacturer's recommended maximum and shall not be less than 60m. The minimum grade shall be 1% and each joint shall be located by survey. Manholes are to be installed at the beginning and end of horizontal curve sections. |
|----------------------------|-----------------|--|

The minimum design velocity in curved sewers is 0.9 m/s.

Sewers larger than 600 mm diameter may include deflections formed by mitred bends to a maximum mitre of 45°.

|                           |                 |  |
|---------------------------|-----------------|--|
| <b>4.9.10 Pipe Joints</b> | Replace Section | All pipe joints shall be gasketed and water tight. |
|---------------------------|-----------------|--|

|                                   |        |  |
|-----------------------------------|--------|--|
| <b>4.9.14 Service Connections</b> | Delete | ▪ Details  |
|                                   |        | Use standard wye fittings for connections to new mains. For connections to existing mains, use wye saddles or, if approved, insertable tees. |
|                                   |        | Service connections may be permitted into manholes if:   |





- The connection is not oriented against the flow in the main.
- Manhole hydraulic requirements are met.

Replace with

- Details

Use standard wye fittings for connections to new mains. For connections to existing mains, use strap on saddle. No other saddles will be permitted. The service connection centreline must not be below the sewer main centreline.

No services shall be directly connected to manholes, all wye connections must be a minimum of 1.0 m downstream from manholes.

**4.10.3 Surface Flow Capacity**

Add to Section

Surface swale shall only traverse three lots downstream before directing into a surface inlet. The swale shall be included in an across lot drainage easement.

**4.11.2 Underground Storage**

Add to Section

Other detention facilities such as underground storage will be considered for approval at the discretion of the City.

**4.11.3 Dry Detention Ponds**

Add to Section

**Design Details for Dry Ponds**

Dry ponds are an effective method of stormwater quantity control, and are typically not intended as water quality improvement facilities. Dry ponds may be constructed in areas where it is not feasible to include a wet pond due to topography or site plan constraints. Generally, dry ponds are used to control larger, less frequent flows while allowing smaller flows to pass through uncontrolled. A sedimentation forebay is required upstream of dry ponds to promote settlement of suspended solids.

a) Land Dedication Requirements

Dry ponds to be operated by the City of Courtenay are to be located on public property, which is to encompass all lands subject to inundation from the 24 hour 1 in 25 year return period design high water level and shall encompass all maintenance access roads as outlined in Section i) below.



If the slope integrity may be jeopardized by cutting or filling of priority lots, a restrictive covenant will be placed on lots abutting the dry pond to control lot development so as not to compromise design requirements at the HWL. This is to ensure an adequate freeboard is maintained.

b) Minimum Pond Size

The City discourages the proliferation of large numbers of small ponds, with the resultant higher maintenance cost and lower efficiency impact. The storage size is determined on the basis of outflow control requirements as presented in this document.

c) Frequency of Operation

All dry ponds shall be off-line storage areas designed to temporarily detain excess runoff and thereby reduce the peak outflow rates to the connected downstream system. These facilities may be subject to prolonged inundation during winter due to the rainfall pattern in Courtenay.

d) Drain Time

Ponds shall be generally designed to completely drain within 40 hours of reaching maximum water surface level, but in no case longer than 72 hours.

e) Side Slopes

Side slopes subject to inundation upon filling of the dry pond shall have a maximum slope of 4 (horizontal) to 1 (vertical) within public property. A freeboard allowance of 0.6 m is required for all dry ponds.

f) Depth of Ponding

The maximum live storage limit in a dry pond is for 3.0 m for the 1 in 25-year return period storm event and 1.5 m for the 1 in 10-year event, as measured from the invert elevation of the outlet pipe.



g) Bottom Grading and Drainage

The dry pond shall be graded to properly drain all areas after its operation. The dry pond bottom shall have a minimum slope of 0.5% and a slope of 0.7% or greater is recommended where feasible. Lateral slopes for the pond bottom shall be 0.5% or greater. French drains or similar means may be required where it is anticipated that these slopes will not properly drain the dry pond bottom, or where dictated by multiple use or other special considerations.

h) Safety Provisions at Inlets and Outlets

All inlet and outlet structures associated with dry ponds shall have grates provided over their openings to restrict access. A maximum clear bar spacing of 0.150 m shall be used for gratings. Grated outlet structures, are to be designed with a hydraulic capacity of at least twice the required capacity to allow for possible plugging. Further, the arrangement of the structures and the location of the grating shall be such that the velocity of the flow passing through the grating will not exceed 1.0 m/s.

Appropriate fencing and guard-rails are to be provided to restrict access and reduce the hazard presented by structure head and wing walls.

i) Maintenance Access Requirements

A minimum 4.0 m wide, all-weather vehicle access shall be constructed from a public road to the inlet, sediment sump, outlet, emergency overflow and other works requiring maintenance. The maximum grade of the access shall be 8%. The surface shall be finished with gravel topped with path chip, geogrid, or rigid grass suitable for all weather maintenance truck access. A vehicle access route shall also be provided to the edge of all stormwater management ponds suitable to carry maintenance vehicles. This access shall also extend to the pond static (normal) water level. The access surface shall include a 1.0 m buffer from top of pond and an additional 1.0 m from edge of access road to the edge of dedicated lands, and shall be accessible from and extend to a public road right-of-way. Sharp bends in this access route are to be



avoided. Vehicle turning movements must accommodate a tandem axle 60,000lb flush truck and tandem axle dump truck.

j) Landscaping

Landscaping plans shall be submitted as part of the Engineering Drawings for dry ponds, and the completion of landscaping will be considered part of the improvement construction. The minimum requirement for landscaping of dry ponds shall be the establishment of grass cover. Preference should be given to use of native plant materials and, in no case, should non-native, aggressive (“invasive”) plant materials be used.

k) Sediment Control

Use of storm ponds for sediment control is only acceptable during construction of the first phase of a development, and must be remediated prior to acceptance of the Works and Services by the City of Courtenay.

l) Operation and Maintenance Manual

Three copies of an operation and maintenance manual shall be submitted when the facility is completed and transferred to the Municipality and include:

- Record drawings of the completed facility.
- Brief description of the facility operation including design flows, design depths, and schematic diagrams of the inlet and outlet structures, connections, controls, valves, bypass, overflows, etc.
- List of manufacturer's operation, service and repair instructions and parts lists.
- Volume-stage-discharge relationships of all control structures.
- General maintenance requirements and emergency procedures.
- Copies of senior government environmental approvals if applicable.



**4.11.4 Wet Detention  
Ponds**

Add to Section

**Design Details for Wet Ponds**

Wet ponds are well suited for both quality and quantity control of stormwater runoff. Wet ponds incorporate a permanent pool which rises in response to rainfall events. Extended storage durations and strategic planting in the active storage zone can further improve water quality. Sedimentation forebays should still be incorporated upstream of wet ponds for preliminary settlement of larger suspended solids.

a) Land Dedication Requirements

Wet ponds to be operated by the City of Courtenay are to be located on Public property which is to encompass all lands subject to inundation from the 24 hour 1 in 25 year return period design high water level plus the edge treatment. This designation will also apply to all rights-of-way for access to and protection of inlet and outlet sewers and flow control facilities, maintenance access routes to the pond, and to a certain proportion of the lands fronting on the pond, from the upper edge of the area containing the edge treatment to the limit of the water's edge when the water surface is at the design high water elevation.

A restrictive covenant and/or a limit for the Minimum Building Elevation (MBE) will be placed upon those lots abutting the pond to guide lot development that design requirements of the stormwater storage facility are not compromised and that an adequate freeboard is maintained.

b) Minimum Pond Size

The City discourages the proliferation of large numbers of small ponds, with the resultant higher maintenance cost and lower efficiency impact. The storage size is determined on the basis of outflow control requirements as presented in this document.

c) Drain Time

Ponds shall be generally designed to drain to normal water surface level within 40 hours of reaching



maximum water surface level, but in no case longer than 72 hours.

d) Side Slopes

Areas covered by water, from the design high water level down to the normal water level shall have a maximum slope of 7 (horizontal) and 1 (vertical) and extend at a maximum slope of 7:1 (H:V), from normal water level to a depth of 0.43 m (i.e., a distance of 3 m horizontally into the pond for safety needs). Steeper side slopes, up to 4:1 (H:V), may be considered for areas separated from the public by a Concrete Rail Fence. A slope of 4:1 (H:V) shall be used from the 0.43 m depth point (below normal water level) to the pond bottom.

e) Minimum Depth

The minimum depth from normal water level to pond bottom (beyond the side slope area) shall be 1.5 m. The maximum live storage limit in a wet pond is for 3.0 m for the 1 in 25-year return period storm event and 1.5 m for the 1 in 10-year event, as measured from the invert elevation of the outlet pipe. A freeboard allowance of 0.6 m is required for all wet ponds.

f) Pond Bottom Material

For areas where the ground water table is below the Normal Water Level (NWL), the pond bottom and side slopes are to be composed of impervious material with a suitably low permeability (e.g. with a permeability coefficient in the order of  $1 \times 10^{-6}$  cm/s).

For areas where the groundwater table is expected to be near or above the NWL, the pond bottom may be of a pervious material as dictated by geotechnical considerations.

g) Circulation Requirements

Narrow and/or dead bay areas where floating debris may accumulate are to be excluded at the design stage. Inlets and outlets should be located with consideration of the need to maximize detention time



and circulation within the pond water body.

h) Inlet and Outlet Requirements

▪ Submergence of Inlets and Outlets

Inlet and outlet pipe inverts are to be a minimum 0.1 m above the pond bottom. Forebays are to be constructed on pond bottom to accommodate extra depth requirements for placing inlet/outlet structures, as required.

▪ Provision for Free Outfall from Inlets to Ponds

Where feasible, the invert elevation at the first manhole upstream from the pond in a minor system or the connecting or interconnecting pipe system, shall be at or above the normal water level of the pond to avoid deposition of sediments in the inlet pipe. To avoid backwater effects on the upstream sewers leading to the pond, the invert of the inlet sewer at the first manhole upstream from the pond shall be at or above the pond level for the 1 in 10-year return period storm event. A drop structure upstream from the pond will generally be required to achieve this. "Inlet" and "outlet" control calculations are required to verify the mode of operation of the pond inlets. In cases where grades set limits on the above, special maintenance needs, such as periodic flushing/cleaning must be identified.

▪ Provisions for Water Level Measurements

To permit direct measurement of water level in the pond, a manhole is to be provided hydraulically connected to the pond such that the level of water in the manhole will mimic the pond water surface level.

▪ Provisions for Lowering the Pond Level

The provision of the means to drain the pond completely by gravity drainage is desirable. Where a gravity drain is not feasible, provisions are to be made in association with the outlet works or



otherwise, so that mobile pumping equipment may be installed and used to drain the pond.

i) Sediment Removal Provisions

The pond design shall include an approved sedimentation removal process for control of heavy solids, which may be washed to the pond during the construction period associated with the development of the contributing drainage catchment.

Sediment basins shall be provided at all inlet locations for continued use after completion of the subdivision development. Stormwater storage/detention ponds shall not take the place of a development's sediment control storage basin.

j) Pond Edge Treatment

Edge treatment or shore protection is required and shall be compatible with the adjacent land use. The treatment used shall meet criteria for low maintenance, safety and habitat requirements. The edge treatment is to cover ground surfaces exposed or covered by water during a pond level fluctuation to 0.3 m below or above the normal water elevation, and shall be adequate to prevent erosion of the pond edge due to wave action. The typical acceptable edge treatment shall be, but is not limited to, a 250 mm deep layer of well graded washed rock with a 75 mm minimum size or alternatively appropriate edge vegetation.

k) Maintenance Access Requirements

A minimum 4.0 m wide, all-weather vehicle access shall be constructed from a public road to the inlet, sediment sump, outlet, emergency overflow and other works requiring maintenance. The maximum grade of the access shall be 8%. The surface shall be finished with gravel topped with path chip, geogrid, or rigid grass suitable for all weather maintenance truck access. A vehicle access route shall also be provided to the edge of all stormwater management ponds suitable to carry maintenance vehicles. This access shall also extend to the pond static (normal) water level. The access surface shall include a 1.0 m buffer





from top of pond and an additional 1.0 m from edge of access road to the edge of dedicated lands, and shall be accessible from and extend to a public road right-of-way. Sharp bends in this access route are to be avoided. Vehicle turning movements must accommodate a tandem axle 60,000lb flush truck and tandem axle dump truck.

l) Landscaping Requirements

Landscaping plans for areas bounding the pond shall be submitted as part of the Engineering Drawings. Landscaping of all proposed public lands included for purposes of the pond and of all proposed lands dedicated to the City for storm ponds on proposed private property, including all areas from the pond edge treatment to the limit of inundation when the pond is filled to the design high water level, is to be part of the pond construction requirement. The minimum requirement for landscaping shall be the establishment of grass cover. Native plant materials must be used.

m) Sediment Control

Use of storm ponds for sediment control is only acceptable during construction of the first phase of a development, and must be remediated prior to acceptance of the Works and Services by the City of Courtenay.

n) Operation and Maintenance Manual

Three copies of an operation and maintenance manual shall be submitted when the facility is completed and transferred to the Municipality and include:

- Record drawings of the completed facility.
- Brief description of the facility operation including design flows, design depths, and schematic diagrams of the inlet and outlet structures, connections, controls, valves, bypass, overflows, etc.
- List of manufacturer's operation, service and repair instructions and parts lists.
- Volume-stage-discharge relationships of all control structures.



|  |                     |  |
|--|---------------------|--|
|  |                     | <ul style="list-style-type: none"> <li>▪ General maintenance requirements and emergency procedures.</li> <li>▪ Copies of senior government environmental approvals if applicable.</li> </ul>   |
| <b>4.11.5 Subsurface Disposal / Infiltration Systems</b> | Delete              | <ul style="list-style-type: none"> <li>▪ May be located on-site or off-site</li> </ul>   |
|  | Replace With        | <ul style="list-style-type: none"> <li>▪ Must be located on-site</li> </ul>  |
| <b>4.11.8 Oil and Grit Separators</b>                    | Replace Section     | Oil and Grit Separators are required for sites with parking for 11 or more vehicles. Oil and Grit Separators must be in compliance with Building Bylaw 2323 and Storm Sewer Bylaw 1402, as amended. The maximum hydraulic loading rate (HLR) will be 27 L/s/m <sup>2</sup> . At the target HLR, the unit will be capable of settling coarse particles of D <sub>50</sub> > 0.115mm at 5 °C and specific gravity of 2.65, and capturing free oil droplets of D <sub>50</sub> > 0.465mm at 5 °C and assuming a specific gravity of 0.88 for a “typical” motor oil. The target effluent shall meet a TSS removal rate of 85%. |
| <b>4.11.10 Alternate Design Standards</b>                | Add Section 4.11.10 | The application of Sustainability Considerations, as described in Section 8.0 of the MMCD Design Guidelines 2014, as well as the Province’s “Stormwater Planning: A Guide for British Columbia” (May 2002), will be considered on a case by case basis by the City where practical.  |
| <b>4.12 Erosion and Sediment Control (ESC)</b>           | Add to Section      | <p>Project specific ESC plans shall be prepared by a Qualified Professional and included with engineering drawing submissions. ESC plans are to include, at minimum:</p> <ul style="list-style-type: none"> <li>▪ ESC plan drawing clearly indicating types and locations of BMP installations</li> <li>▪ Notes describing any BMP phasing, inspection and documentation requirements, and good housekeeping practices</li> <li>▪ Detail drawings of BMPs with specific material and installation requirements</li> </ul>  |





**5.0 ROADS**

**5.3 Cross-Section Elements** Replace Section Refer to the Courtenay Supplementary Standard Drawings for typical road cross sections for each road classifications. Typical road cross sections are to be applied where identified in the Official Community Plan – Bylaw No. 2387, Road Network – Map No. 3. Design speeds of the typical road sections are provided in Table 5.4 below.

**5.4.2 Vertical Curves** Replace Table 5.4 Replace Table 5.4 as follows:

**Table 5.4 Alignment Standards**

| Classification                          | Design Speed (km/h) | Min. Radius (m) | Grade (%) |                  | K-Value      |        |            |        | Minimum Sight Distance (m) |          |
|---|---------------------|-----------------|-----------|------------------|--------------|--------|------------|--------|----------------------------|----------|
|   |                     |                 |           |                  | Crest Curves |        | Sag Curves |        |                            |          |
|   |                     |                 | Min       | Max              | Min.         | Desir. | Min.       | Desir. | Stopping                   | Decision |
| Arterial Road Section: B                | 60                  | 120             | 0.5       | 6                | 10           | 13     | 8          | 9      | 95-235                     | 95-235   |
| Collector Road Section: Urban – P       | 50                  | 85              | 0.5       | 8                | 6            | 7      | 5          | 6      | 75-200                     | 75-200   |
| Collector Road Section: Urban – B       | 50                  | 85              | 0.5       | 8                | 6            | 7      | 5          | 6      | 75-200                     | 75-200   |
| Collector Road Section: Residential – C | 50                  | 85              | 0.5       | 8                | 6            | 7      | 5          | 6      | 75-200                     | 75-200   |
| Collector Road Section: Residential – B | 50                  | 85              | 0.5       | 8                | 6            | 7      | 5          | 6      | 75-200                     | 75-200   |
| Collector Road Section: Residential     | 50                  | 85              | 0.5       | 8                | 6            | 7      | 5          | 6      | 75-200                     | 75-200   |
| Collector Road Section: Rural           | 60                  | 120             | 0.5       | 8                | 10           | 13     | 8          | 9      | 95-235                     | 95-235   |
| Local Road Section                      | 50                  | 35              | 0.5       | 10               | 6            | 7      | 5          | 6      | 75-200                     | 75-200   |
| Lane                                    | 30                  | 25              | 1.0       | 12               | 2            | 4      | 2          | 4      | 45                         | -        |
| Driveway Multi-Family                   | 30                  | -               | 0.5       | 12               | 2            | 4      | 2          | 4      | 45                         | -        |
| Driveway Single Family                  | -                   | -               | 0.5       | 12               | -            | -      | -          | -      | -                          | -        |
| Emergency Access <sup>8</sup>           | 30                  | 12              | 1.0       | 12               | 2            | 4      | 2          | 4      | 45                         | -        |
| Pedestrian Ramps                        | -                   | -               | 1.0       | 8.3 <sup>6</sup> | -            | -      | -          | -      | -                          | -        |

**5.7 Railway Grade Crossings** Replace Section Locations and details of railway grade crossings are subject to requirements included in the latest edition of the Transportation Canada Grade Crossing Standards.



Railway crossing signs and pavement marking shall be in accordance with Transportation Canada Grade Crossing Standards.

|               |   |                    |   |
|---------------|---|--------------------|---|
| <b>5.8</b>    | <b>Traffic Control Devices</b>                                  | Replace Section    | Traffic control devices, signs, and pavement marking must be in accordance with the Manual of Uniform Traffic Control Devices for Canada. Pavement markings shall be thermoplastic and shall be installed within 7 days of the final pavement lift on a clean and dry surface.  |
| <b>5.9</b>    | <b>Culs-De-Sac</b>  | Delete             | The maximum road length for a cul-de-sac, as measured from the edge of the intersecting through road to the centre of the cul-de-sac bulb, is 200m  |
|               |   | Replace with       | The maximum road length for a cul-de-sac, as measured from the edge of the intersecting through road to the centre of the cul-de-sac bulb, is 300m  |
| <b>5.9.1</b>  | <b>Temporary Turnaround</b>                                     | Add Section 5.9.1  | Where a road terminates and there is future access to lands beyond; a turnaround shall be provided in a form acceptable to the City, and may be located on private property if protected by a right-of-way and covenant registered in favour of the City. The turnaround shall be signed as a 'fire access' with no parking allowed. The right-of-way and covenant shall be discharged when the road connection is completed. |
| <b>5.10.1</b> | <b>Traffic Barriers at Temporary Cul-De-Sac and Turnarounds</b> | Add Section 5.10.1 | A concrete barrier shall be located at the end of a temporary cul-de-sac and turnarounds.   |
| <b>5.11.1</b> | <b>Sidewalk</b>   | Replace Section    | Sidewalk location and width shall be as per Courtenay Standard Detail Drawings for typical road cross sections for different road classifications. Minimum cross fall for sidewalk shall be 2% towards the gutter, except at driveway letdowns.   |
| <b>5.11.2</b> | <b>Pedestrian Crossings</b>                                     | Replace Section    | The warrant for pedestrian crossings must be considered as part of a broader analysis process which should include an understanding of existing site conditions, pedestrian and traffic volumes, and pedestrian accessibility. This can be evaluated utilizing TAC Pedestrian Crossing Control Guide.   |



The pedestrian crossing width can range from a minimum of 2.5 m to as wide as 4.0 m. (TAC Design Guidelines, Section 2.3.14.1). The pavement marking and signage configuration for crossings must be designed in accordance with TAC.

Wheel chair ramps from sidewalks, medians and traffic islands to crosswalks must be provided at intersections and multiuse pathways. Locations and details of ramps and related pedestrian safety features must be in accordance with local bylaws and the TAC Geometric Design Guide.

Sidewalks, crosswalks, and pedestrian facilities must be designed in accordance with the following guidelines:

- TAC Geometric Design Guideline, 1999 (Section 2.2.6, Section 2.3.14, Section 3.3)
- TAC – Pedestrian Crossing Control Manual, 2012
- Pedestrian Crossing Control Manual for British Columbia, Second Edition, 1994  
BC Ministry of Transportation – Manual of Standard Traffic Signs & Pavement Markings

|                                |                    |  |
|--------------------------------|--------------------|--|
| <b>5.14.4 Driveway Grades</b>  | Delete Sentence    | For the first 10 m on private property, the maximum driveway grade is 15% if accessing a local or collector road.  |
|                                | Replace with       | For the first 10 m on private property, the maximum driveway grade is 12% if accessing a local or collector road.  |
| <b>5.14.8 Driveway Surface</b> | Add Section 5.14.8 | New or altered driveways shall be concrete or asphalt within the road right-of-way.  |
| <b>5.15.3 Signs and Poles</b>  | Delete Sentence    | Use of minimum clearance should be justified by safety appurtenances such as poles with break-away or frangible bases or sign poles of light weight fabrication.                       |
| <b>5.15.4 Trees</b>            | Replace Section    | Provide 1 boulevard tree per single residential or duplex dwelling lot where required. For all other developments provide 1 boulevard tree per 15-22m of lot frontage and/or flankage. |

Boulevard trees are required on the same side of the street as sidewalks and are not required on rural roads.



Boulevard trees are to be located where there is a minimum space of 1.5m between the sidewalk and back of curb. Horizontal clearance from edge of driveway, curb return or above ground utility to tree trunk is 2.5m. Boulevard trees are to be located no closer than 6m from the adjacent street right of way at intersections.

Boulevard trees are to be a minimum of 3cm caliper.

The cost for each boulevard tree shall be \$800.00. The cost includes the price of the tree, installation that may include root barriers, maintenance and replacement if the tree does not survive.

The Developer shall provide a boulevard tree layout plan showing the location and number of trees and the location of utilities, prepared by a Qualified Professional to the satisfaction of the Development Engineer.

|               |                                      |                  |   |
|---------------|--------------------------------------|------------------|---|
| <b>5.16</b>   | <b>Underground Utility Locations</b> | Replace Section  | Underground utility locations within a road right-of-way will vary with the road cross section. Refer to the Courtenay Supplementary Standard Drawings for the general location of underground utilities and minimum separation requirements within the various cross sections. |
| <b>5.17.3</b> | <b>Pavement Alternatives</b>         | Replace Section  | Pavement structure design must be based on site specific recommendations provided by a Qualified Professional and shall include the minimum pavement structure identified in the City of Courtenay Supplementary Standard Detail Drawing for the relevant road classification.  |
| <b>5.21</b>   | <b>Street Parking</b>                | Replace Section  | Refer to the Courtenay Standard Drawings for parking configuration for different road classifications.  |
| <b>5.22</b>   | <b>Retaining Walls</b>               | Add Section 5.22 | Retaining wall shall be a maximum of 1.8 m in height. Where larger retaining walls heights are required, they must be constructed as a stepped wall.  |

**SUPPLEMENTARY DESIGN GUIDELINES  
ROADWAY LIGHTING**





**6.0 ROADWAY LIGHTING**

|   |                |   |
|---|----------------|---|
| <b>6.1 General</b>                        | Add to Section | Relevant publications of the Illuminating Society of North America (IESNA) including RP-8-14  |
| <b>6.2.2 Standards and Guidelines</b>     | Add to Section | IESNA – Illuminating Engineering Society of North America<br>IDA – International Dark-Sky Association   |
| <b>6.5.1 Light Sources and Luminaires</b> | Delete         | Light sources shall be LED, Induction, High Pressure Sodium or Pulse Start Metal Halide.<br>The selection process shall be based on a review of energy efficiency, cost/benefit (installation and operational) and optical performance which shall be undertaken in consultation with the jurisdiction that will own and operate the lighting.                      |
|   | Replace with   | Light sources shall only be LED. The selection process shall be undertaken in consultation with the City of Courtenay and will only include luminaire manufacturers listed in the current version of the City’s Approved Product List. All streetlights shall include flat lenses.<br><br>If BC Hydro lease lights are used, they shall meet BC Hydro requirements. |
| <b>6.7 Sidewalk Lighting</b>              | Delete         | Sidewalk lighting levels for various pedestrian activity levels are defined in Figure 6.3, Sidewalk Illuminance Table below.  |
|   | Replace with   | Sidewalk lighting levels for various pedestrian activity levels are defined in Figure 6.7, Sidewalk Illuminance Table below.  |
| <b>6.8 Intersection Lighting</b>          | Delete         | Intersection lighting levels for various street types and pedestrian activity levels are defined in the Intersection Horizontal Illuminance Table 6.4 below.  |
|   | Replace with   | Intersection lighting levels for various street types and pedestrian activity levels are defined in Figure 6.8 Horizontal Illuminance Table below.  |
| <b>6.9 Crosswalk Lighting</b>             | Delete         | This can be achieved by placing poles in advance of the crosswalk (see Figure below) to create high levels of   |



|   |        |              |   |
|---|--------|--------------|---|
|   |        |              | vertical illumination thus improving driver visibility of pedestrians.  |
|   |        | Replace with | This can be achieved by placing poles in advance of the crosswalk (see Figure 6.5 below) to create high levels of vertical illumination thus improving driver visibility of pedestrians.  |
| <b>6.13 Poles</b>                         | Delete |              | For rural roads, if approved by the local authority and the power company, lights may be installed on power poles.  |
|   |        | Replace with | Luminaires may be installed on power poles, if approved by the City and BC Hydro.   |
| <b>6.14 Pole Foundations</b>              | Delete |              | Where soil conditions are in question a geotechnical engineer must be consulted to define the suitability of the base for the given soil's condition.   |
|   |        | Replace with | Where standard MMCD foundations are not suitable for site soil conditions, custom foundations will be required, and shall be designed, signed and sealed by a Qualified Professional registered as a Professional Engineer in the province of British Columbia. |
| <b>6.15 Luminaires</b>                    | Delete |              | <ul style="list-style-type: none"> <li>▪ Colour temperature shall not exceed 4500 kelvin.</li> </ul>  |
|   |        | Replace with | <ul style="list-style-type: none"> <li>▪ LED luminaire colour temperature shall not exceed 3000 kelvin.</li> </ul>  |
| <b>6.16 Power Supply and Distribution</b> | Delete |              | Lighting system shall be fed via a service base or pole mounted cabinet which shall contain panel boards, breakers, lighting contactor(s) and photocell bypass switch as per MMCD Standard Specifications and Drawings.   |
|   |        | Replace with | Lighting system shall be fed via a pad mount or pole mount cabinet which shall contain panel boards, breakers, lighting contactor(s) and bypass switch as per MMCD Standard Detail Drawings and Specifications.   |
|   |        | Delete       | Power is generally supplied by the utility through an un-metered service when servicing only streetlights and traffic signals; however, some utility power providers may require metered services.  |



|                                    |                |  |
|------------------------------------|----------------|--|
|                                    | Replace with   | Power is generally supplied by the utility through an un-metered service when servicing only streetlights and traffic signals unless metering is required by BC Hydro.   |
|                                    | Delete         | Services are to be “Underground Dip” type as shown on the MMCD Standard Specifications and Drawings unless otherwise accepted by the local Municipality/City   |
|                                    | Replace with   | Services are to be “Underground Dip” type as shown on the MMCD Standard Specifications and Drawings or overhead drops, as specified on the design drawings.  |
| <b>6.17.4 Drawing Requirements</b> | Add to Section | <ul style="list-style-type: none"><li>▪ Design submissions for City approval shall include relevant load calculators for signal and sign poles as well as other relevant engineering calculations and design drawings</li><li>▪ Record drawings submissions shall include 3 - ½ size paper copy sets of drawings as well as pdf and AutoCAD electronic files of drawings</li></ul> |
|                                    | Delete         | Design drawings shall be submitted for approval along with signed and sealed computer lighting calculations.   |

**SUPPLEMENTARY DESIGN GUIDELINES  
TRAFFIC SIGNALS**



**7.0 TRAFFIC SIGNALS**

**7.3.1 Codes, Rules and Regulations** Add to Section 

- BC Motor Vehicle Act, Motor Vehicle Act Regulations, Division 23

**7.4 Signal Heads** Replace Figure 7.4.2 Replace Figure 7.4.2 as follows:

**Table 7.4.2 Signal Head Sizes**

| Signal Head Type        | Area Classification Lens Size and Shape                 |
|-------------------------|---|
| Primary                 | 300 mm round  |
| Secondary and Auxiliary | 300 mm round  |
|                         | 300 mm round  |
| Pedestrian              | Combination walk/don't walk indication<br>300 mm square |

**7.8 Signal Pre-Emption** Add to Section The City utilizes siren actuated emergency pre-emption equipment. Pre-emption equipment to be located 1 m right of the left most signal head.

**7.9 Audible Pedestrian Signals** Add to Section The City utilizes Accessible Pedestrian Signals.

**7.11 Detection Methods** Replace Section Traffic detection for signal actuation is accomplished by:

- Vehicle detector loops (induction)
- A vehicle detector loop is a coil of wire buried in the road surface. The coil detects the presence of a vehicle by the change in electrical induction. This change is sensed by the detector module in the traffic control cabinet. Detector loop details are indicated in the MMCD Standard Detail Drawings.

**7.15 Poles and Foundations** Add to Section Where standard MMCD foundations are not suitable for site soil conditions, custom foundations will be required, and shall be designed, signed and sealed by a Qualified Professional registered as a Professional Engineer in the province of British Columbia

**7.18 Power Supply and Distribution** Add to Section Traffic signal systems shall be fed via a pad mount or pole mount cabinet which shall contain panel boards, breakers, lighting contactor(s) and bypass switch as per MMCD Standard Detail Drawings and Specifications



|             |   |              |  |
|-------------|---|--------------|--|
|             |   |              | <p>Power is generally supplied by the utility through an un-metered service when servicing only streetlights and traffic signals unless metering is required by BC Hydro.</p> <p>Services are to be “Underground Dip” type as shown on the MMCD Standard Detail Drawings and Specifications or overhead drops, as specified on the design drawings.</p>                            |
| <b>7.19</b> | <b>Uninterruptible Power Supplies (UPS’s)</b> | Delete       | <p>UPS’s are required where traffic signals are interconnected by grade crossing warning systems as per Transport Canada. UPS’s shall be considered where power outages are a concern or the intersection is in a high collision or a high risk area.</p>  |
|             |   | Replace with | <p>Uninterruptible power supplies shall be utilized at all new traffic signal installations.</p>   |
| <b>7.21</b> | <b>Drawing Requirements</b>                   | Add bullets  | <ul style="list-style-type: none"><li>▪ Design submissions for City approval shall include relevant load calculators for signal and sign poles as well as other relevant engineering calculations and design drawings</li><li>▪ Record drawings submissions shall include 3 - ½ size paper copy sets of drawings as well as pdf and AutoCAD electronic files of drawings</li></ul> |

**SCHEDULE 2**  
**SUPPLEMENTARY CONSTRUCTION SPECIFICATIONS**



### CONSTRUCTION SUPPLEMENTARY SPECIFICATIONS

This schedule contains supplementary specifications to be applied in conjunction with the Specifications of the Master Municipal Construction Documents, dated 2009, both of which shall apply to all Works and Services constructed within the City of Courtenay.

Supplementary Specifications contained within this Schedule supplement or supersede the Master Municipal Construction Document (MMCD). Where the City of Courtenay Supplementary Specifications are in conflict with the MMCD, the City of Courtenay Supplementary Specifications shall take precedence.

Section number and clause numbers in the City of Courtenay Supplementary Specifications coincide with the MMCD numbering protocol.

#### TABLE OF CONTENTS

##### SECTION

|                  |   |
|------------------|---|
| <u>01 55 00S</u> | TRAFFIC CONTROL, VEHICLE ACCESS AND PARKING |
| <u>01 57 01S</u> | ENVIRONMENTAL PROTECTION                    |
| <u>26 56 01S</u> | ROADWAY LIGHTING                            |
| <u>31 05 17S</u> | AGGREGATES AND GRANULAR MATERIALS           |
| <u>33 11 01S</u> | WATERWORKS                                  |
| <u>33 30 01S</u> | SANITARY SEWERS                             |
| <u>33 40 01S</u> | STORM SEWERS                                |
| <u>33 44 01S</u> | MANHOLES AND CATCHBASINS                    |
| <u>34 41 13S</u> | TRAFFIC SIGNALS                             |





MMCD Section 01 55 00S TRAFFIC CONTROL, VEHICLE ACCESS AND PARKING

1.0 GENERAL

Add 1.0.6

The Contractor is responsible for all temporary traffic control required to complete the Work. The Contractor will be responsible to provide a Traffic Management Plan (TMP) for review and acceptance by the City (10) ten working days prior to any travel lane closures taking place. TMP is to be prepared by a qualified professional.

The TMP shall outline the approach to traffic management, show recognition and minimization of risks indicates signing locations, identify Traffic Control Persons (TCP) stations, show lane shifting and proposed closures.

The TMP is to be revised and resubmitted as required during the progress of the work



MMCD Section 01 57 01S

ENVIRONMENTAL PROTECTION

1.0 GENERAL

1.2 Temporary Erosion and Sediment Controls

Add 1.2.1.4

An Erosion & Sediment Control (ESC) Plan must be prepared by a Certified Professional in Erosion and Sediment Control. The ESC Plan is to be reviewed by the City prior to the start of construction. Protection of the site and watercourses to which it drains, directly or indirectly, against erosion and siltation must be maintained in accordance with the ESC Plan until the *Works* are completed or as directed by the *Contract Administrator*.

The *Contractor* is responsible for all damage that may be caused by water backing up or flowing over, through from or along any part of the *Work* or otherwise resulting from their operations.

Add 1.2.1.5

Keep existing culverts, drains, ditches and watercourses affected by the *Work* clear of excavated material at all times. When it is necessary to remove or alter any existing drainage structure, provide suitable alternative measures for handling the drainage. Adequately support culverts and drainpipes across trenches to prevent displacement and interference with the proper flow of water due to trench settlement.

Add 1.2.1.6

Sweep streets, and clean catch basins, manhole sumps, detention tanks, and maintain siltation controls as often as the *Contract Administrator* deems necessary.

Add 1.2.1.7

Follow all Federal and Provincial regulations and guidelines respecting protection of fish, fish habitat, and watercourses.

1.4 Environmental Protection

Add 1.4.3.5

Immediately contain and clean up any leaks and spills of prohibited materials at the *Place of Work*.





MMCD Section 26 56 01S

ROADWAY LIGHTING

2.0 PRODUCTS

|      |                       |  |   |
|------|-----------------------|--|---|
| 2.1  | General               | Delete 2.1.2 and replace with the following  | All products supplied to be new, in accordance with Contract Documents. All products are to meet Canadian Electrical Code requirements and be certified by either CSA, ULC, or Intertek Testing Systems (Warnock Hersey) and be supplied with the certifier's label.  |
| 2.8  | Conductors and Cables | Delete 2.8.1 and replace with the following  | Single Conductors: 600V, conductor size (AWG) as noted on contract drawings, stranded copper or aluminum type with RW90 polyethylene insulation, to conform to CSA C22.2 No. 38, 90 °C and colour coded per CEC.  |
|      |                       | Add 2.8.5                                    | <p>Minimum conductor size to be as follows, unless specified otherwise on Contract Drawings:</p> <ul style="list-style-type: none"> <li>.1 No 8 AWG copper or No 6 AWG aluminum for feeder conductors in conduit.</li> <li>.2 No 8 AWG copper or No 6 AWG aluminum for bond conductors in conduit.</li> <li>.3 No 12 AWG copper for luminaire conductors in poles.</li> </ul> |
| 2.14 | Luminaires            | Delete 2.14.1 and replace with the following | LED luminaires shall be listed on the current edition of the City of Courtenay Approved Products list.  |
|      |                       | Delete 2.14.2                                |   |
|      |                       | Delete 2.14.5 and replace with the following | <p>Decorative luminaires to have:</p> <ul style="list-style-type: none"> <li>.1 Vandal resistant features</li> <li>.2 Photo-control receptacle</li> <li>.3 Powder coat finish</li> <li>.4 Quick disconnect terminations</li> </ul>  |
| 2.19 | Service Panels        | Add 2.19.1                                   | Type 40A 120/240V, 60A 120/240V roadway lighting and 100A 120/240V combination roadway lighting / traffic signal, per Contract Drawings to include items listed within the Section 34 41 13 - Traffic Signals - 2.11.2 and Standard Detail Drawing E7.1 to E7.9   |



3.0 EXECUTION

|      |                           |  |   |
|------|---------------------------|--|---|
| 3.3  | Concrete Bases            | Add 3.3.7                                    | All concrete bases shall be pre-cast concrete only, unless noted on Contract Drawings or directed by the Contract Administrator.  |
| 3.4  | Junction Boxes and Vaults | Add 3.4.5                                    | All junction boxes shall be provided with RPVC bars to support electrical connections and fuse holders. The RPVC bars shall be attached into the junction box side walls with the electrical connections/fuse holders tie-wrapped in place and installed in the up-right position.                                |
| 3.5  | Underground Conduit       | Add 3.5.6                                    | Conduits shall be blown out with compressed air, from both ends if necessary, then swabbed with the appropriate size mandrel to remove stones, dirt, water and other material which may have entered during installation.   |
|      |                           | Add 3.5.7                                    | Conduit shall not be bent in the field. Only factory bends will be accepted.  |
| 3.8  | Wiring                    | Delete 3.8.11 and replace with the following | Bond all luminaires and receptacles with No. 12 RW90 copper green conductor, and steel junction box lids with No. 8 RW90 copper green conductor.  |
|      |                           | Add 3.8.12                                   | Aluminum conductors shall be spliced with H-Tap compression connections or equivalent. Spliced connections shall be completed using an anti-oxidant compound complete with split bolt connector. Spliced connections shall be wrapped with self-fusing rubberized tape and then completely covered with PVC tape. |
| 3.13 | Pole Finish Application   | Delete 3.13 and replace with the following   | .1 Pole finish: Hot dip galvanized or powder coat<br>.2 Power coat colour to be confirmed with City   |



MMCD Section 31 05 17S      AGGREGATES AND GRANULAR MATERIALS

2.0      PRODUCTS

2.11      Recycled Aggregate Material      Delete 2.11.1 and replace with the following      Aggregates containing recycled material may be utilized if approved by the Contract Administrator. A maximum of 25% recycled aggregate may be used in sub-base gravel, and a maximum of 15% recycled aggregate is permitted in base gravel. In addition to meeting all other conditions of this specification, recycled material should not reduce the quality of construction achievable with quarried materials. Recycled material shall consist only of aggregates, crushed portland cement concrete, or asphalt that is free of impurities.

2.13      Path Chip      Add Clause 2.13.1: To be crushed gravel conforming to following gradations:

---

| Sieve Designation | Percent Passing |   |     |
|-------------------|-----------------|---|-----|
| 9.5mm             |                 |   | 100 |
| 4.75mm            | 80              | – | 100 |
| 2.36mm            | 40              | – | 60  |
| 1.18mm            | 20              | – | 40  |
| 0.6mm             | 10              | – | 30  |
| 0.3mm             | 8               | – | 20  |
| 0.15mm            | 5               | – | 15  |
| 0.075mm           | 3               | – | 10  |

---



MMCD Section 33 11 01S

WATERWORKS

1.0 GENERAL

|     |                    |   |  |
|-----|--------------------|---|--|
| 1.7 | Scheduling of Work | Delete 1.7.5 and replace with the following | Notify Contract Administrator, fire department and City of Courtenay Public Works Office of any planned or accidental interruption of water supply. After hours phone number to be identified at the project initiation meeting. |
|-----|--------------------|---|--|

2.0 PRODUCTS

|     |         |   |  |
|-----|---------|---|--|
| 2.1 | General | Delete 2.1.1 and replace with the following | Pipe material as shown on Contract Drawings, excluding main pipe within chambers or structures, which shall be stainless steel, and leads to fire hydrants which shall be PVC. |
|-----|---------|---|--|

|     |                                    |   |  |
|-----|------------------------------------|---|--|
| 2.2 | Mainline Pipe, Joints and Fittings | Delete 2.2.4.8.1 and replace with the following | Flange gaskets to be manufactured from black natural rubber 3.175mm thick. |
|-----|------------------------------------|---|--|

|  |   |
|--|---|
| Delete 2.2.4.14.1.8 and replace with the following | Tapping machine must have provision for pressure testing. |
|--|---|

|     |                        |   |  |
|-----|------------------------|---|--|
| 2.3 | Valves and Valve Boxes | Delete 2.3.6.2 and replace with the following | Valve box riser to be 150mm diameter PVC C900. |
|-----|------------------------|---|--|

|     |  |   |   |
|-----|--|---|---|
| 2.5 | Service Connections, Pipe, Joints and Fittings | Delete 2.5.5 and replace with the following | Copper tubing joints to be compression type suitable for 1100 kPa working pressure. |
|-----|--|---|---|

|     |          |   |  |
|-----|----------|---|--|
| 2.6 | Hydrants | Delete 2.6.1.6.3 and replace with the following | Pump nozzle shall be "quick connect" STORZ type. |
|-----|----------|---|--|

|   |  |
|---|--|
| Delete 2.6.2 and replace with the following | Colour: As specified in the approved products list |
|---|--|



3.0 EXECUTION

|      |   |  |  |
|------|---|--|--|
| 3.17 | General Procedure Flushing, Testing, and Disinfection | Add 3.17.7                                   | Contractor shall record locations of installed testing point locations as per paragraph 1.7.2.2 under Section 01 33 01 Project Record Documents.   |
| 3.18 | Cleaning and Preliminary Flushing                     | Delete 3.18.2 and replace with the following | Isolation of existing water system where required will be performed by the City. Do not operate any existing valves.   |
| 3.23 | Connection to Existing Mains                          | Delete 3.23.1 and replace with the following | Connections to the existing waterworks system will be made by the City or by the Contractor under supervision of the City. Contractor to make all necessary scheduling arrangements with the City to prevent construction delays.  |
|      |   | Add 3.23.2                                   | Isolation of existing water system where required will be performed by the City. The Contractor shall not operate any existing valves.   |
|      |   | Add 3.23.3                                   | The contractor is to schedule a “pre-construction” meeting to occur a minimum of one (1) week prior to connection to the existing waterworks system. This meeting will include, at minimum, the Contractor, Contract Administrator, and City of Courtenay Public Works in attendance. The purpose of this meeting is to review all pre-connection documentation, public notifications, and works to be completed by both the Contractor and City of Courtenay. |







MMCD Section 33 40 01S

STORM SEWERS

2.0 PRODUCTS

|     |                     |   |   |
|-----|---------------------|---|---|
| 2.6 | Service Connections | Delete 2.6.1 and replace with the following | Storm sewer service connections to be 150 mm minimum diameter; maximum diameter as specified on Contract Drawings |
|-----|---------------------|---|---|

3.0 EXECUTION

|      |                        |            |   |
|------|------------------------|------------|---|
| 3.12 | Inspection and Testing | Add 3.12.4 | The Contractor shall complete CCTV video inspection prior to completing paving works and again prior to the expiry of the maintenance period. CCTV Video inspection shall be completed for all gravity mains including service connections. |
|------|------------------------|------------|---|



MMCD Section 33 44 01S

MANHOLES AND CATCHBASINS

1.0 GENERAL

- 1.1 Related Work
  - Add 1.1.6 Hot Mix Asphalt Concrete Pavement Section 32 12 16
  - Add 1.1.7 Portland Cement Concrete Pavement Section 32 13 13

3.0 EXECUTION

- 3.3 Manhole Installation
  - Delete 3.3.15 and replace with the following Install drop structures where required to Standard Detail Drawings S3. Inside drop structure shall not be permitted.



MMCD Section 34 41 13S

TRAFFIC SIGNALS

2.0 PRODUCTS

|               |                                |   |  |
|---------------|--------------------------------|---|--|
| 2.1           | General                        | Delete 2.1.2 and replace with the following   | All products supplied to be new, in accordance with Contract Documents. All products are to meet Canadian Electrical Code requirements and be certified by either CSA, ULC, or Intertek Testing Systems (Warnock Hersey) and be supplied with the certifier's label.               |
| 2.16          | Traffic and Pedestrian Signals | Delete 2.16.2 and replace with the following  | Yellow as indicated on the contract drawings, complete with 50 mm wide ASTM VI retro-reflective tape around the outer edge.  |
| 2.20          | Audible Signals                | Delete 2.20.1 and replace with the following  | The City utilizes APS audible signals which are specified in the current edition of the City's Approved Product list.  |
| 2.22          | Luminaires                     | Delete 2.22.1 and replace with the following<br><br>Delete 2.22.2<br><br>Delete 2.22.5 and replace with the following | LED luminaires are specified in the current edition of the City's Approved Products list.<br><br>Decorative luminaires to have:<br>1. Vandal resistant features<br>2. Photo-control receptacle<br>3. Powder coat finish<br>4. Quick disconnect terminations                        |
| 2.27          | Video Detection System         | Delete 2.27   |  |
| 3.0 EXECUTION |                                |   |  |
| 3.3           | Concrete Bases                 | Add 3.3.7   | All concrete bases shall be pre-cast concrete only, unless noted on Contract Drawings or directed by the Contract Administrator.   |
| 3.4           | Junction Boxes and Vaults      | Add 3.4.5   | All junction boxes shall be provided with RPVC bars to support electrical connections and fuse holders. The RPVC bars shall be attached into the junction box side walls with the electrical connections/fuse holders tie-wrapped in place and installed in the up-right position. |



|      |   |  |   |
|------|---|--|---|
| 3.5  | Underground Conduit                         | Add 3.5.6                                    | Conduits shall be blown out with compressed air, from both ends if necessary, then swabbed with the appropriate size mandrel to remove stones, dirt, water and other material which may have entered during installation. |
|      |   | Add 3.5.7                                    | All conduits entering traffic controller cabinets shall be sealed with "Duct Seal".   |
|      |   | Add 3.5.8                                    | Conduit shall not be bent in the field. Only factory bends will be accepted.  |
| 3.7  | Traffic and Pedestrian Signal Head Mounting | Delete 3.7.4 and replace with the following  | Completely cover all traffic and pedestrian signal heads with dark coloured pre-manufactured signal cover bags from the time they are installed until system startup.   |
| 3.16 | Traffic Controller                          | Add 3.16.8                                   | Traffic cabinet interior shall be kept dry during inclement weather.  |
| 3.22 | Pole Finish Application                     | Delete 3.22.1 and replace with the following | Pole finish: Hot dip galvanized or powder coat. Powder coat colour to be confirmed with the City  |

**SCHEDULE 3**  
**SUPPLEMENTARY STANDARD DETAIL DRAWINGS**

## SUPPLEMENTARY STANDARD DETAIL DRAWINGS

This schedule contains supplementary standard detail drawings to be applied in conjunction with the Standard Detail Drawings of the Master Municipal Construction Documents, dated 2009, both of which shall apply to all Works and Services constructed within the City of Courtenay.

Supplementary Standard Detail Drawings contained within this Schedule supplement or supersede the Master Municipal Construction Document (MMCD). Where the City of Courtenay Supplementary Standard Detail Drawings are in conflict with the MMCD, the City of Courtenay Supplementary Standard Detail Drawings shall take precedence.

Drawing numbers in the City of Courtenay Supplementary Standard Detail Drawings coincide with the MMCD numbering protocol.

### TABLE OF CONTENTS

#### DETAIL DRAWING

|                  |   |
|------------------|---|
| <u>CSSD A1</u>   | ALTERNATIVE DESIGN STANDARD 1: MULTI-USE PATH                                       |
| <u>CSSD A2</u>   | ALTERNATIVE DESIGN STANDARD 2: GRAVEL TRAIL   |
| <u>CSSD A3</u>   | ALTERNATIVE DESIGN STANDARD 3: LANE   |
| <u>CSSD L1</u>   | LOCAL ROAD SECTION  |
| <u>CSSD CRu</u>  | COLLECTOR ROAD SECTION: RURAL   |
| <u>CSSD CRe</u>  | COLLECTOR ROAD SECTION: RESIDENTIAL   |
| <u>CSSD CRB</u>  | COLLECTOR ROAD SECTION: RESIDENTIAL – B   |
| <u>CSSD CRC</u>  | COLLECTOR ROAD SECTION: RESIDENTIAL – C   |
| <u>CSSD CUB</u>  | COLLECTOR ROAD SECTION: URBAN – B   |
| <u>CSSD CUP</u>  | COLLECTOR ROAD SECTION: URBAN – P   |
| <u>CSSD AB</u>   | ARTERIAL ROAD SECTION: B  |
| <u>CSSD R2</u>   | MINIMUM PAVEMENT STRUCTURE REQUIREMENTS   |
| <u>CSSD R3</u>   | CUL-DE-SAC  |
| <u>CSSD R4</u>   | HAMMERHEAD TURNAROUND (PRIVATE ROADS)   |
| <u>CSSD R5</u>   | STREET NAME SIGN AND BASE DETAIL  |
| <u>CSSD R6</u>   | TYPICAL BULB OUT LOCATION AND DETAILS   |
| <u>CSSD C7b</u>  | DRIVEWAY CROSSING FOR BARRIER CURBS - TYPE 2  |
| <u>CSSD C7c</u>  | DRIVEWAY CROSSING FOR BARRIER CURBS - TYPE 3  |
| <u>CSSD C8a</u>  | WHEELCHAIR RAMP FOR SIDEWALK, INFILL AND BARRIER CURBS                              |
| <u>CSSD C10</u>  | CONCRETE WALKWAY  |
| <u>CSSD C12</u>  | REMOVABLE BOLLARD   |
| <u>CSSD E2.1</u> | ROUND PLASTIC JUNCTION BOXES  |
| <u>CSSD I1</u>   | IRRIGATION CONNECTION   |
| <u>CSSD I2</u>   | IRRIGATION SWING JOINT  |
| <u>CSSD I3</u>   | TYPICAL INSTALLATIONS LARGE LINE / TWIN BACKFLOW VALVES / MASTER VALVE / FLOW METER |
| <u>CSSD P1</u>   | TREE PLANTING AND STAKING   |

|                 |  |
|-----------------|--|
| <u>CSSD S7</u>  | SANITARY SEWER SERVICE CONNECTION 100MM RESIDENTIAL SANITARY |
| <u>CSSD S8</u>  | STORM SEWER SERVICE CONNECTION 150MM RESIDENTIAL STORM       |
| <u>CSSD S9</u>  | INSPECTION CHAMBER FOR SANITARY AND STORM SEWER CONNECTIONS  |
| <u>CSSD S11</u> | TOP INLET CATCH BASIN  |
| <u>CSSD S16</u> | WET DETENTION POND PLAN AND SECTION                          |
| <br>            |  |
| <u>CSSD W2a</u> | WATER SERVICE CONNECTION SERVICE BOX                         |
| <u>CSSD W2c</u> | WATER METER SETTER INSTALLATION FOR 25MM SERVICE CONNECTION  |
| <u>CSSD W2d</u> | WATER METER SETTER INSTALLATION FOR 50MM SERVICE CONNECTION  |
| <u>CSSD W2e</u> | WATER METER INSTALLATION FOR GREATER THAN 50MM SERVICE       |
| <u>CSSD W2f</u> | FIRE / DOMESTIC WATER SERVICE PIPING LAYOUT                  |
| <u>CSSD W8</u>  | TEMPORARY AND PERMANENT BLOW-OFF FOR WATERMAIN               |



**CITY OF COURTENAY**  
**SUPPLEMENTARY STANDARD DETAIL DRAWING**

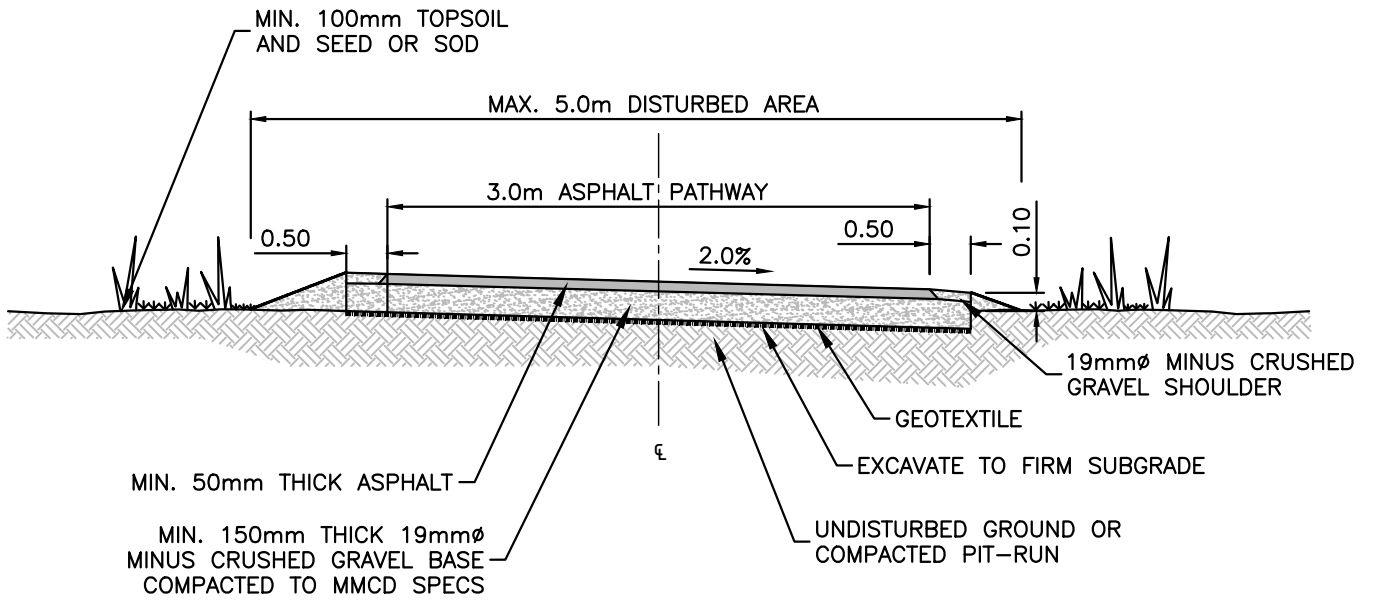

**NOTE:**

1. GRAVEL DEPTH TO SUIT GROUND CONDITIONS.
2. 150Ø DR-28 PVC DRAIN TO BE INSTALLED WHERE REQUIRED.
3. MATERIALS AND CONSTRUCTION TO MEET CURRENT CITY OF COURTENAY SPECIFICATIONS.
4. THE CONTRACTOR IS RESPONSIBLE FOR EROSION AND SEDIMENT CONTROLS AS REQUIRED TO COMPLETE THE WORK. THE CONTRACTOR IS TO SUPPLY A "SEDIMENT & EROSION CONTROL PLAN" FOR REVIEW BY THE CITY PRIOR TO CONSTRUCTION.
5. ALL MATERIALS TO BE SUPPLIED & CONSTRUCTED AS PER THE MOST RECENT VERSION OF THE MASTER MUNICIPAL CONTRACT DOCUMENTS (MMCD).
6. IF ACCESS REQUIRED BY CITY PUBLIC WORKS, PATHWAY MUST INCLUDE A MINIMUM UNOBSTRUCTED ACCESS OF 4.0m.
7. WHERE PATHWAY INTERSECTS WITH CITY ROAD OR SIDEWALK, THE FIRST 5.0m IS TO BE CONSTRUCTED OF CONCRETE COMPLETE WITH REMOVABLE BOLLARD PER DETAIL CSSD C12. SEE DETAIL CSSD C10 FOR DETAILS.

NOVEMBER, 2017



**ALTERNATIVE DESIGN STANDARD 1**  
**MULTI-USE PATH**

DRAWING NUMBER

**CSSD A1**

REVISION NUMBER

0

SCALE

N.T.S.

**145**

**CITY OF COURTENAY**  
**SUPPLEMENTARY STANDARD DETAIL DRAWING**

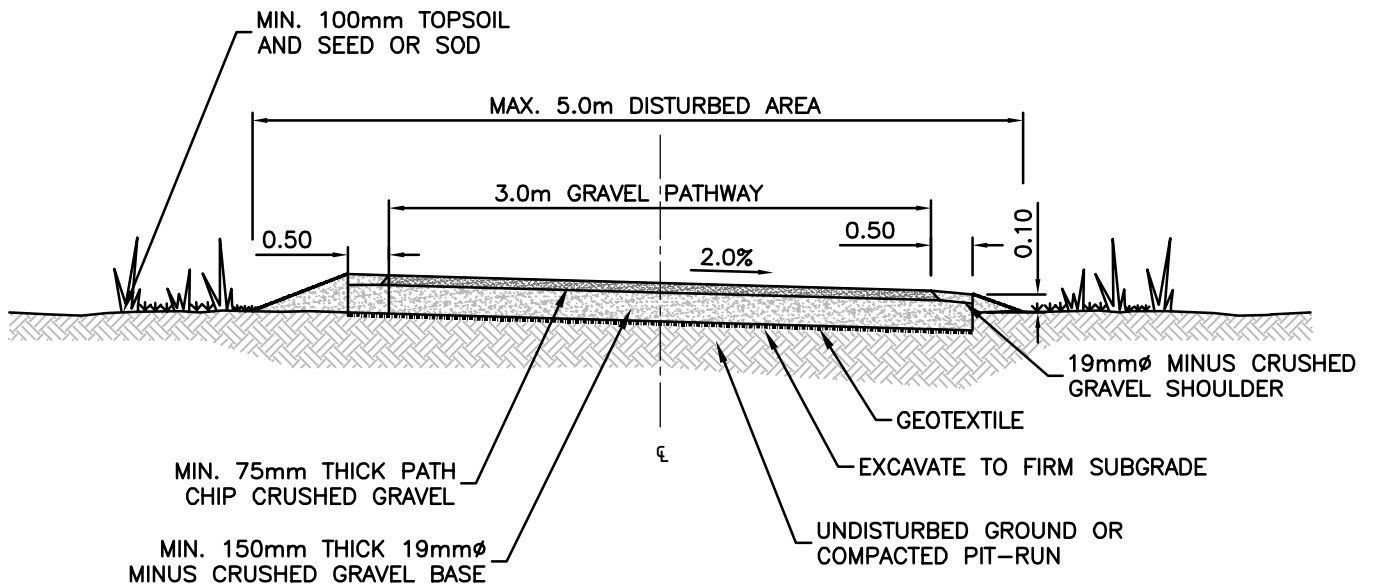

**NOTE:**

1. GRAVEL DEPTH TO SUIT GROUND CONDITIONS.
2. 150 $\phi$  DR-28 PVC DRAIN TO BE INSTALLED WHERE REQUIRED.
3. MATERIALS AND CONSTRUCTION TO MEET CURRENT CITY OF COURTENAY SPECIFICATIONS.
4. THE CONTRACTOR IS RESPONSIBLE FOR EROSION AND SEDIMENT CONTROLS AS REQUIRED TO COMPLETE THE WORK. THE CONTRACTOR IS TO SUPPLY A "SEDIMENT & EROSION CONTROL PLAN" FOR REVIEW BY THE CITY PRIOR TO CONSTRUCTION.
5. ALL MATERIALS TO BE SUPPLIED & CONSTRUCTED AS PER THE MOST RECENT VERSION OF THE MASTER MUNICIPAL CONTRACT DOCUMENTS (MMCD).
6. WHERE PATHWAY INTERSECTS WITH CITY ROAD OR SIDEWALK, THE FIRST 5.0m IS TO BE CONSTRUCTED OF CONCRETE COMPLETE WITH REMOVABLE BOLLARD PER DETAIL CSSD C12. SEE DETAIL CSSD C10 FOR DETAILS.

NOVEMBER, 2017



ALTERNATIVE DESIGN STANDARD 2  
 GRAVEL TRAIL

DRAWING NUMBER

CSSD A2

REVISION NUMBER

0

SCALE

N.T.S.  
 146

CITY OF COURTENAY  
 SUPPLEMENTARY STANDARD DETAIL DRAWING

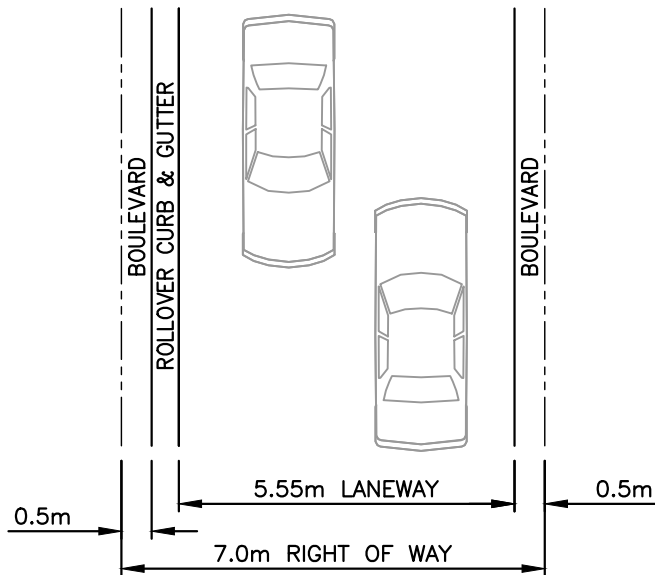
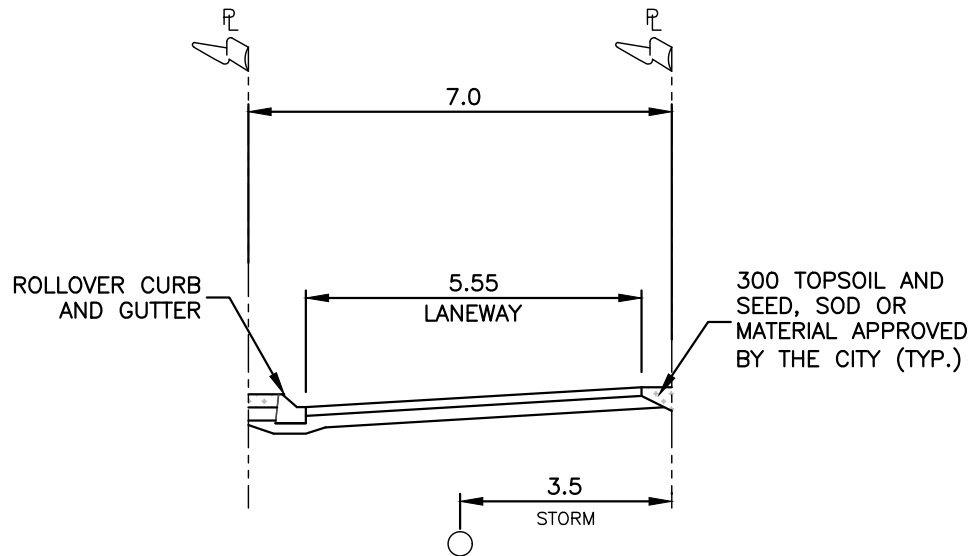

NOVEMBER, 2017



ALTERNATIVE DESIGN STANDARD 3  
 LANE

DRAWING NUMBER

CSSD A3

REVISION NUMBER

0

SCALE

N.T.S.  
 147

**CITY OF COURTENAY  
SUPPLEMENTARY STANDARD DETAIL DRAWING**

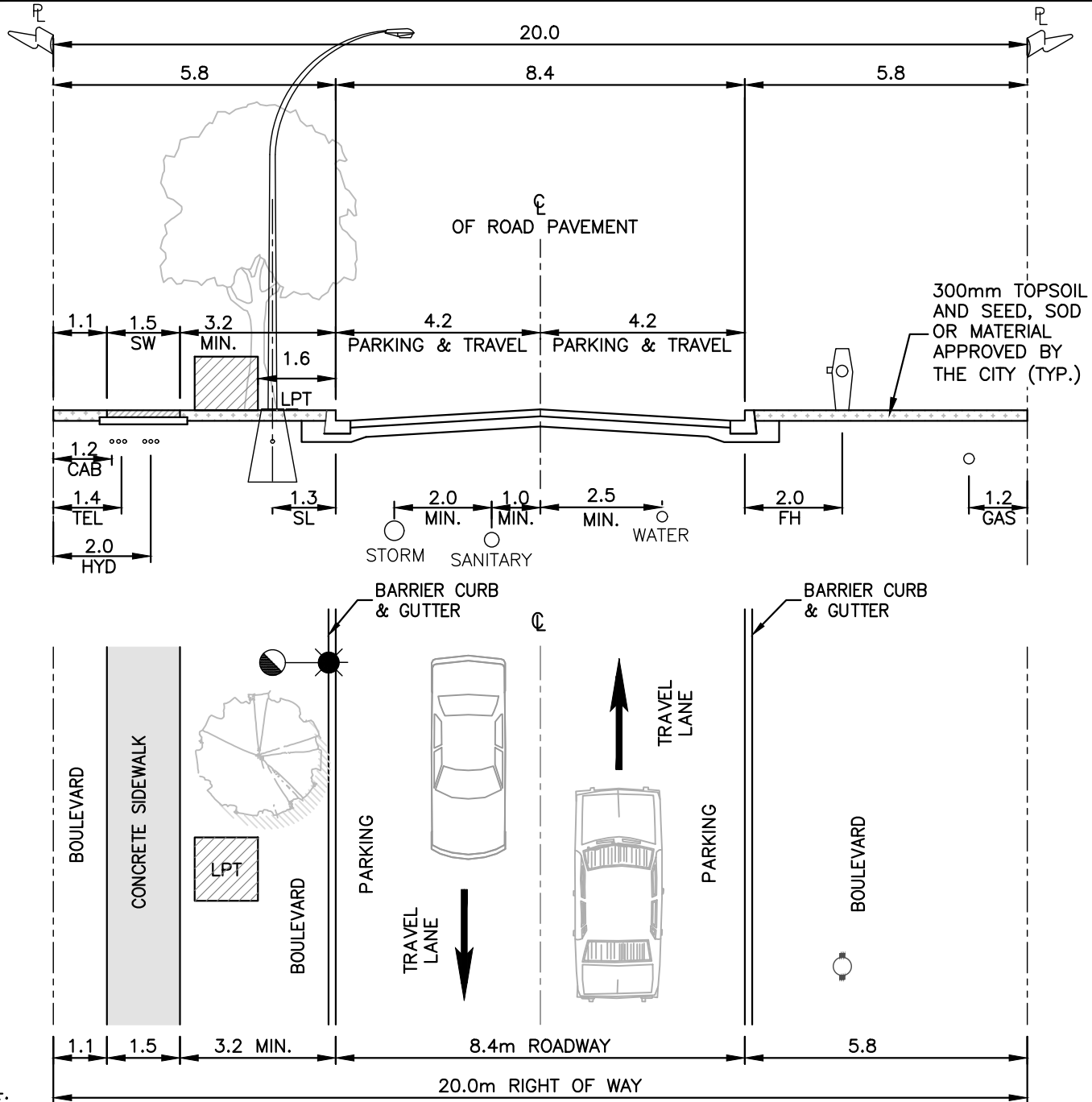

NOTE:

1. PAVEMENT MARKINGS NOT REQUIRED FOR THE CENTRE LINES, INTERSECTION APPROACHES AND FOG LINES.
2. 3rd PARTY UTILITY DESIGN TO BE PROVIDED BY THE RESPECTIVE UTILITIES.
3. THE STRUCTURAL ROAD ELEMENTS SHOWN ARE MINIMUM REQUIREMENTS. ROAD STRUCTURE TO BE DESIGNED BASED ON SITE CONDITIONS BY A QUALIFIED GEOTECHNICAL ENGINEER.
4. SIDEWALK TO BE LOCATED ON NORTH OR WEST SIDE OF ROAD.
5. HYDRO SERVICE BOX TO INCLUDE A STORM SEWER SERVICE CONNECTION AS PER CSSD S8. INSPECTION CHAMBER TO BE LOCATED 300mm FROM SERVICE BOX.
6. TREES TO BE CENTRED IN BOULEVARDS.

NOVEMBER, 2017



**LOCAL ROAD SECTION**

DRAWING NUMBER

**CSSD L1**

REVISION NUMBER

0

SCALE

N.T.S.

**148**

**CITY OF COURTENAY  
SUPPLEMENTARY STANDARD DETAIL DRAWING**

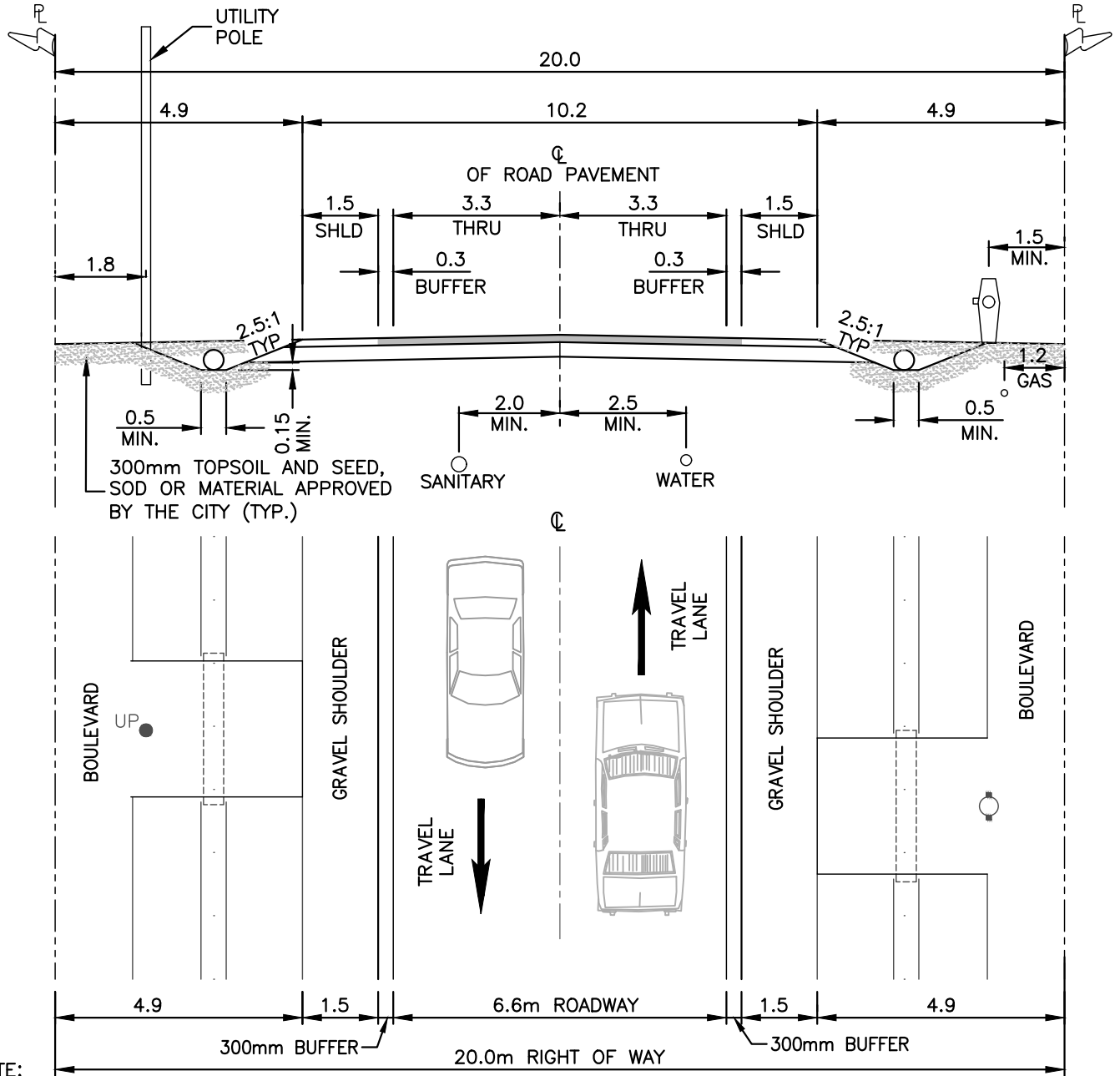

NOTE:

1. DESIGNATED BIKE ROUTE TO HAVE 1.5m PAVED AND 0.5m GRAVEL SHOULDER ON BOTH SIDES.
2. PAVEMENT MARKINGS TO INCLUDE: CENTRE LINE AND FOG LINES TO TAC STANDARD.
3. 3.0m LONG CULVERT CROSSING TO BE INSTALLED IN FRONT OF HYDRANT (C/W HEADWALLS), SIZED APPROPRIATELY FOR DRAINAGE FLOWS (MIN. 300mm).
4. REQUIREMENT FOR ROADSIDE BARRIER TO BE DETERMINED AS PER TAC WARRANT.
5. ADDITIONAL 0.75m ASPHALT WIDTH TO BE ADDED TO SHOULDER WIDTH IF ROADSIDE BARRIER IS REQUIRED.
6. 3rd PARTY UTILITY DESIGN TO BE PROVIDED BY THE RESPECTIVE UTILITIES.
7. IF UTILITY POLE LOCATED WITHIN DITCH PROFILE, 3.0m LONG CULVERT TO BE INSTALLED IN FRONT OF UTILITY POLE.

NOVEMBER, 2017



**COLLECTOR ROAD SECTION  
RURAL**

DRAWING NUMBER

**CSSD CRu**

REVISION NUMBER

0

SCALE

N.T.S.

**149**

**CITY OF COURTENAY  
SUPPLEMENTARY STANDARD DETAIL DRAWING**

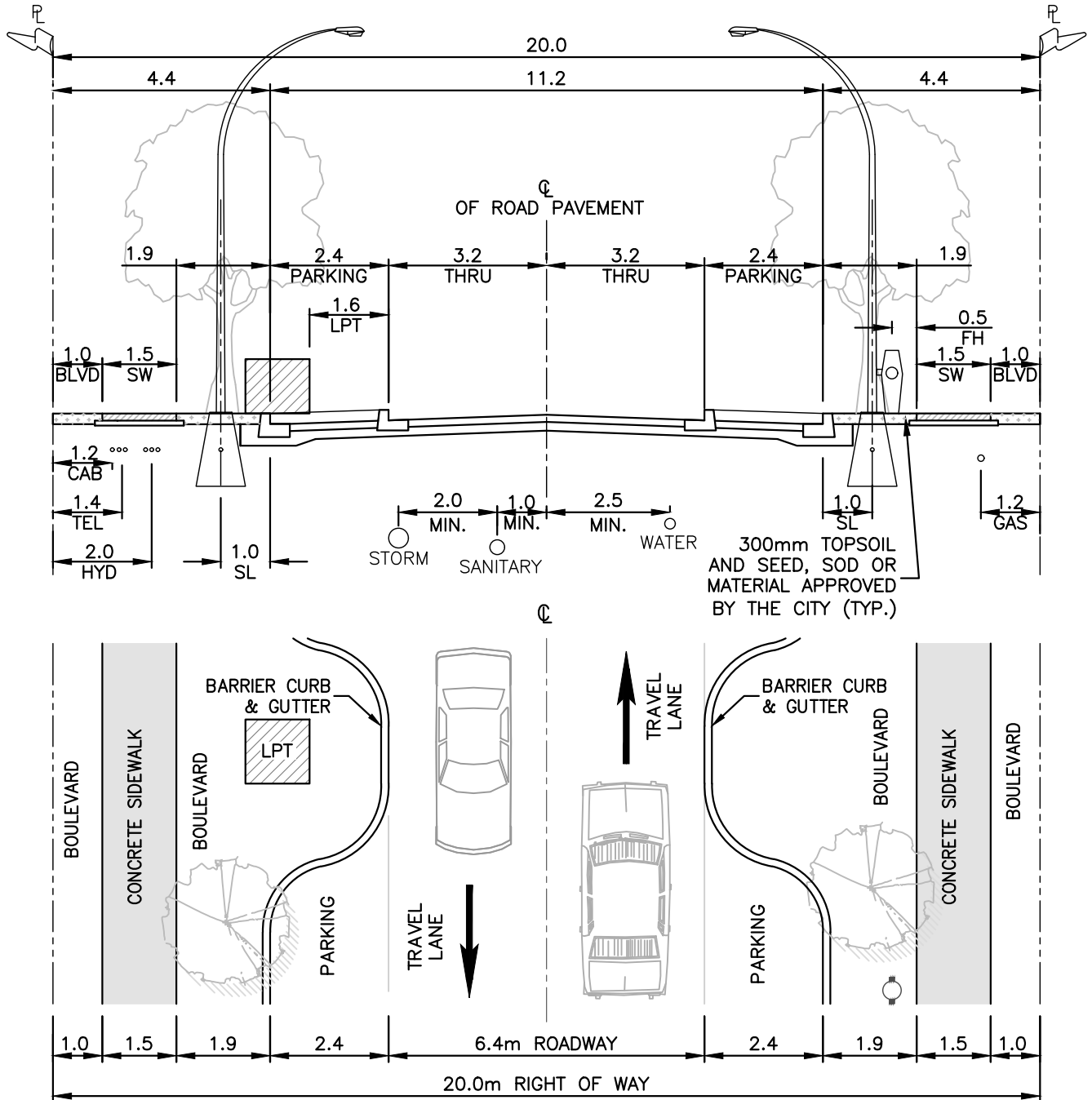

NOTE:

1. PAVEMENT MARKINGS TO INCLUDE: CENTRE LINE, LANE LINE, AND TRANSVERSE ROAD MARKINGS TO TAC STANDARD.
2. 3rd PARTY UTILITY DESIGN TO BE PROVIDED BY THE RESPECTIVE UTILITIES.
3. BULB OUTS TO BE LOCATED AT LPTS, CROSSWALKS AND INTERSECTIONS TO DELINEATE PARKING POCKETS.
4. HYDRO SERVICE BOX TO INCLUDE A STORM SEWER SERVICE CONNECTION AS PER CSSD S8. INSPECTION CHAMBER TO BE LOCATED 300mm FROM SERVICE BOX.
5. TREES TO BE CENTRED IN BOULEVARDS.

NOVEMBER, 2017



**COLLECTOR ROAD SECTION  
RESIDENTIAL**

DRAWING NUMBER

**CSSD CRe**

REVISION NUMBER

0

SCALE

N.T.S.  
**150**

**CITY OF COURTENAY  
SUPPLEMENTARY STANDARD DETAIL DRAWING**

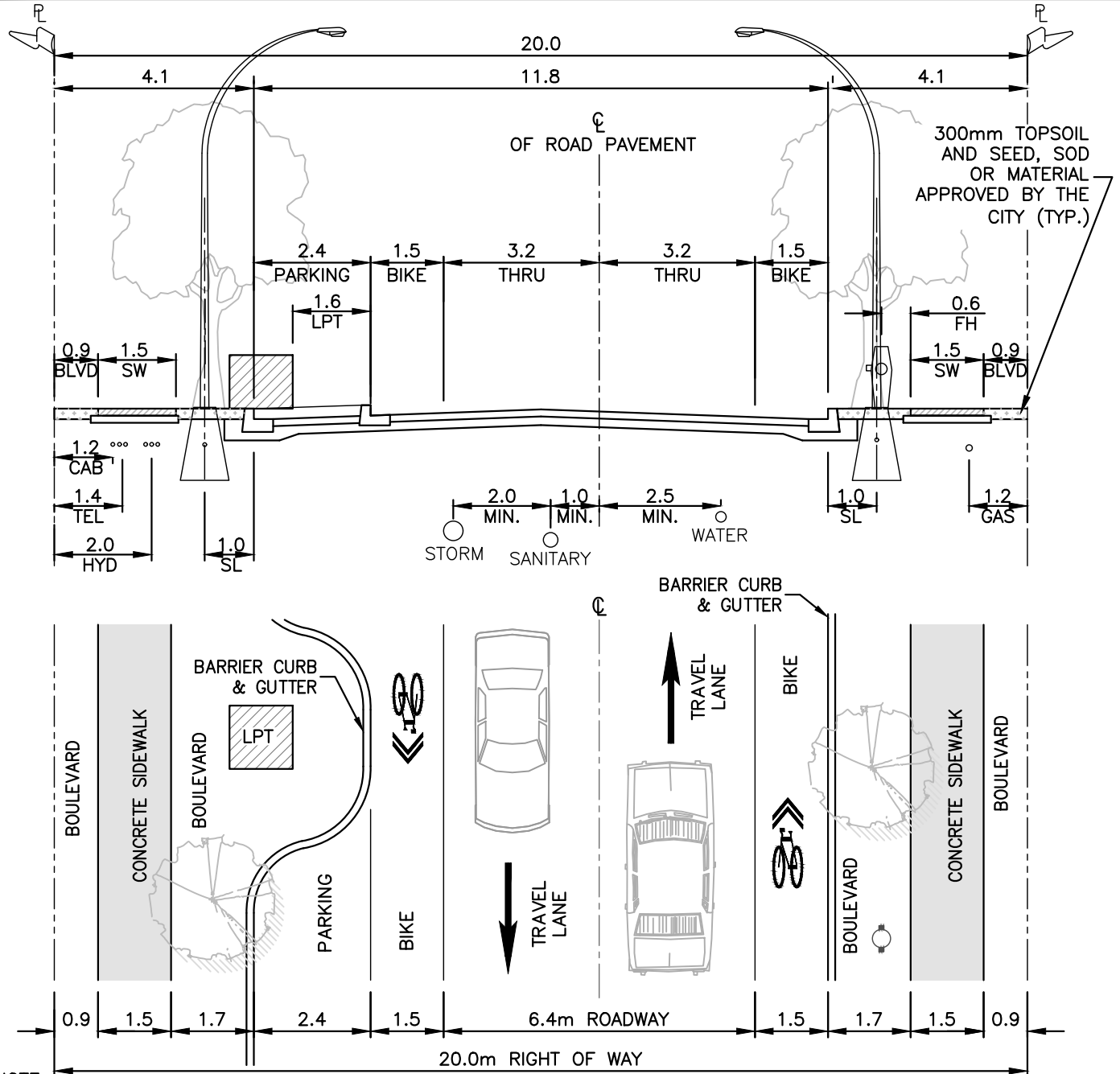

NOTE:

1. PAVEMENT MARKINGS TO INCLUDE: CENTRE LINE, LANE LINES, BIKE LANES AND ALL TRANSVERSE MARKINGS TO TAC STANDARD.
2. 3rd PARTY UTILITY DESIGN TO BE PROVIDED BY THE RESPECTIVE UTILITIES.
3. BULB OUTS TO BE LOCATED AT LPTS, CROSSWALKS AND INTERSECTIONS TO DELINEATE PARKING POCKETS.
4. PARKING PROVISION TO BE ON NORTH OR WEST SIDE OF ROAD.
5. HYDRO SERVICE BOX TO INCLUDE A STORM SEWER SERVICE CONNECTION AS PER CSSD S8. INSPECTION CHAMBER TO BE LOCATED 300mm FROM SERVICE BOX.
6. TREES TO BE CENTRED IN BOULEVARDS.

NOVEMBER, 2017



**COLLECTOR ROAD SECTION  
RESIDENTIAL – B**

DRAWING NUMBER

**CSSD CRB**

REVISION NUMBER

0

SCALE

N.T.S.

**151**

**CITY OF COURTENAY  
SUPPLEMENTARY STANDARD DETAIL DRAWING**

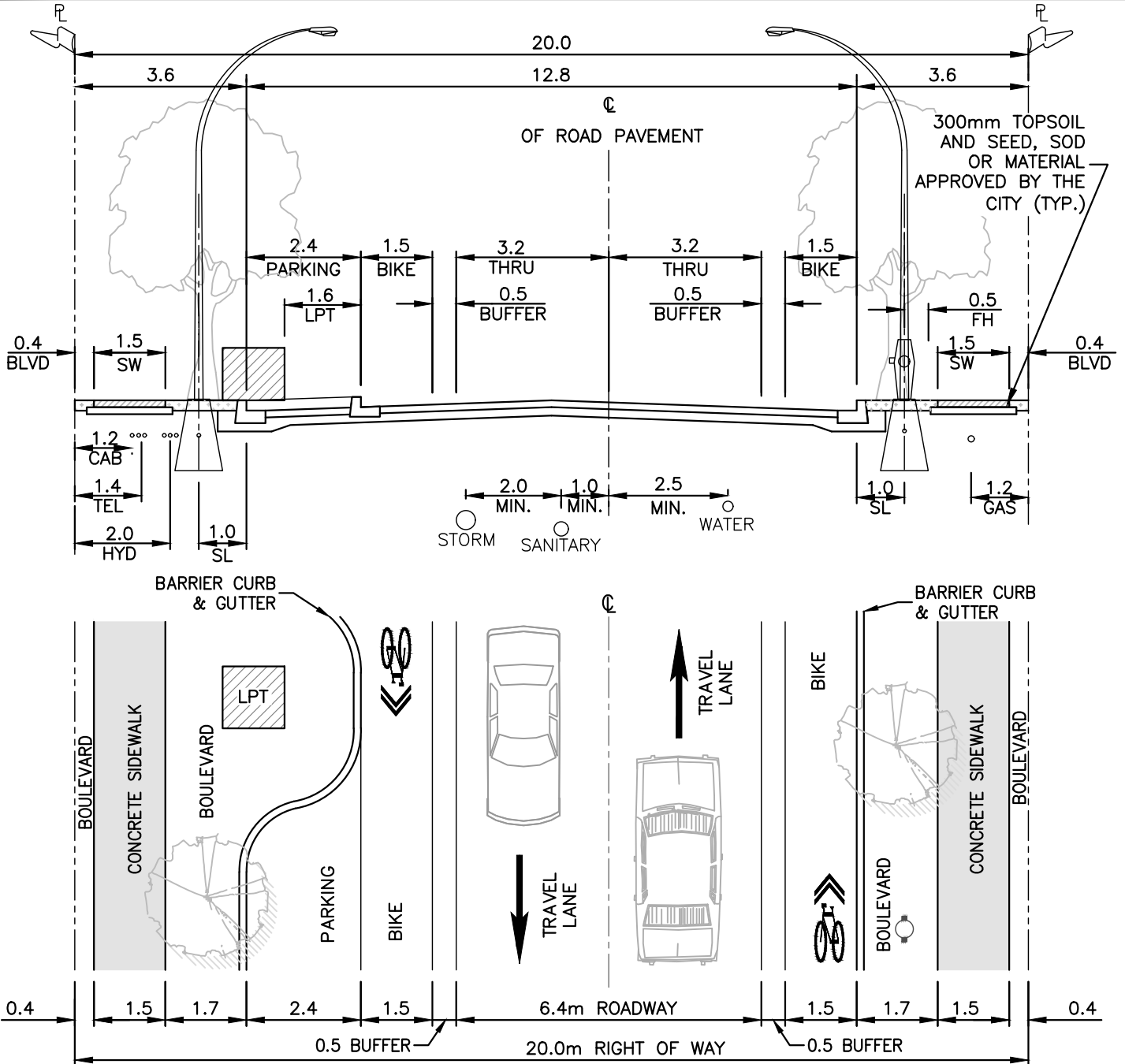

NOTE:

1. PAVEMENT MARKINGS TO INCLUDE: CENTRE LINE, LANE LINES, BIKE LANES, AND TRANSVERSE ROAD MARKINGS TO TAC STANDARD.
2. BIKE LANE BUFFER TO BE HATCHED / GORE TO TAC STANDARD.
3. 3rd PARTY UTILITY DESIGN TO BE PROVIDED BY THE RESPECTIVE UTILITIES.
4. BULB OUTS TO BE LOCATED AT LPTS, CROSSWALKS AND INTERSECTIONS TO DELINEATE PARKING POCKET.
5. HYDRO SERVICE BOX TO INCLUDE A STORM SEWER SERVICE CONNECTION AS PER CSSD S8. INSPECTION CHAMBER TO BE LOCATED 300mm FROM SERVICE BOX.
6. TREES TO BE CENTRED IN BOULEVARDS.

NOVEMBER, 2017



**COLLECTOR ROAD SECTION  
RESIDENTIAL - C**

DRAWING NUMBER

**CSSD CRC**

REVISION NUMBER

0

SCALE

N.T.S.

**152**



**CITY OF COURTENAY  
SUPPLEMENTARY STANDARD DETAIL DRAWING**

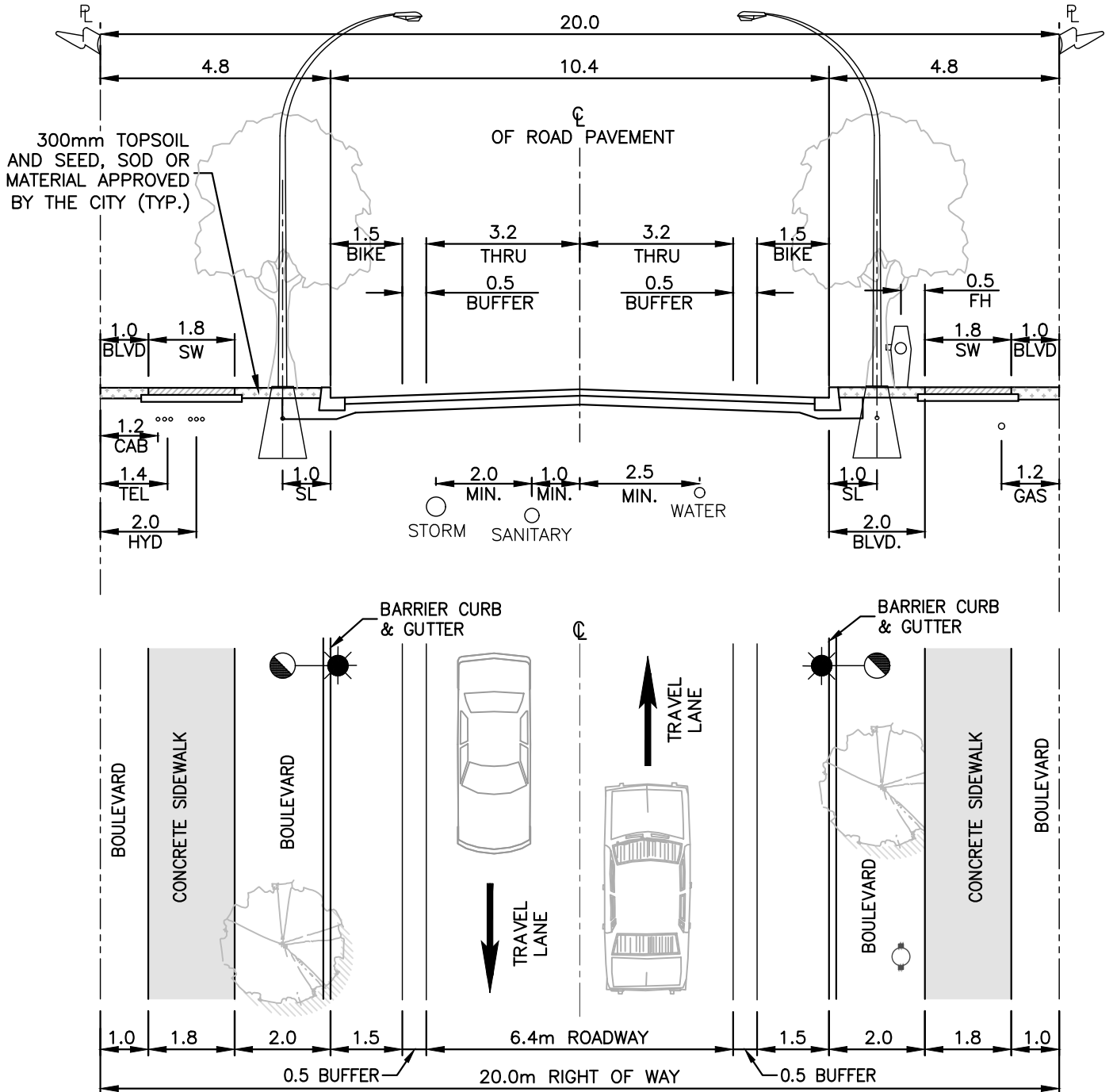

**NOTE:**

1. PAVEMENT MARKINGS TO INCLUDE: CENTRE LINE, BIKE LANES AND TRANSVERSE ROAD MARKINGS TO TAC STANDARD.
2. BIKE LANE BUFFER TO BE HATCHED / GORE TO TAC STANDARD.
3. 3rd PARTY UTILITY DESIGN TO BE PROVIDED BY THE RESPECTIVE UTILITIES.
4. THIS ROAD SECTION ASSUMES NO HYDRO LOADS OR LPT.
5. TREES TO BE CENTRED IN BOULEVARDS.

NOVEMBER, 2017



**COLLECTOR ROAD SECTION  
URBAN - B**

|                 |                 |
|-----------------|-----------------|
| DRAWING NUMBER  | <b>CSSD CUB</b> |
| REVISION NUMBER | 0               |
| SCALE           | N.T.S.          |

**CITY OF COURTENAY  
SUPPLEMENTARY STANDARD DETAIL DRAWING**

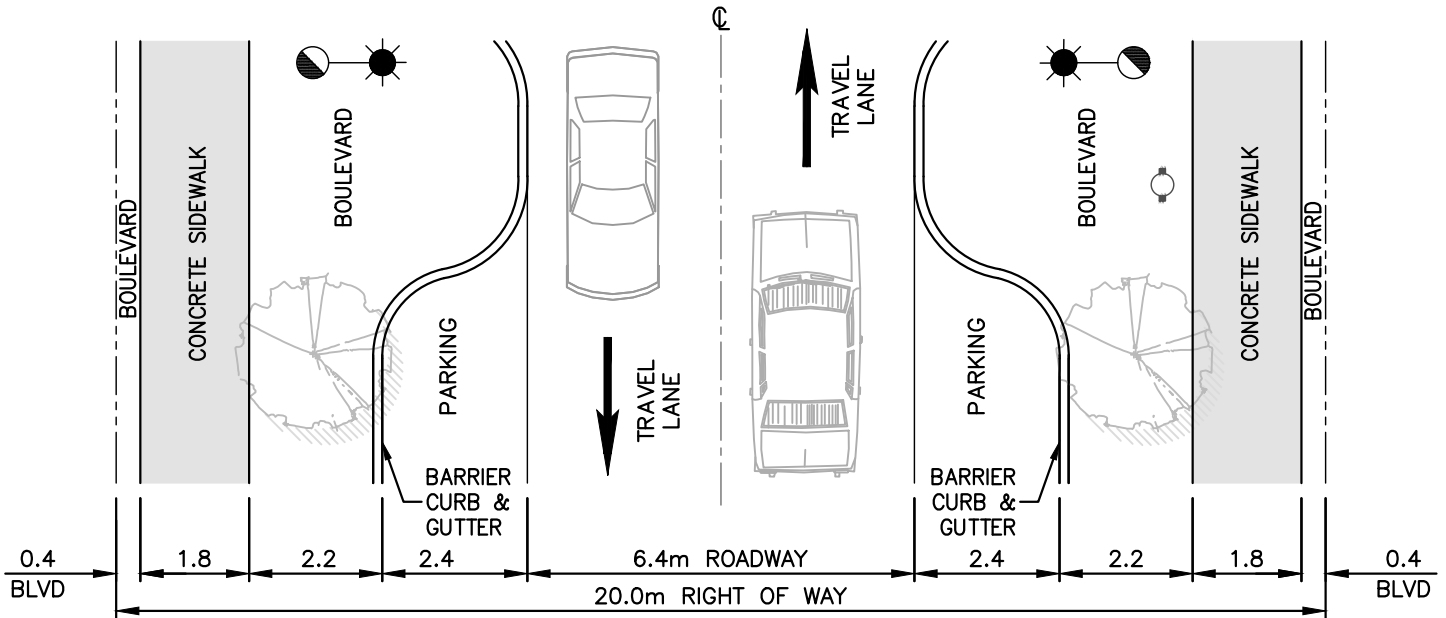
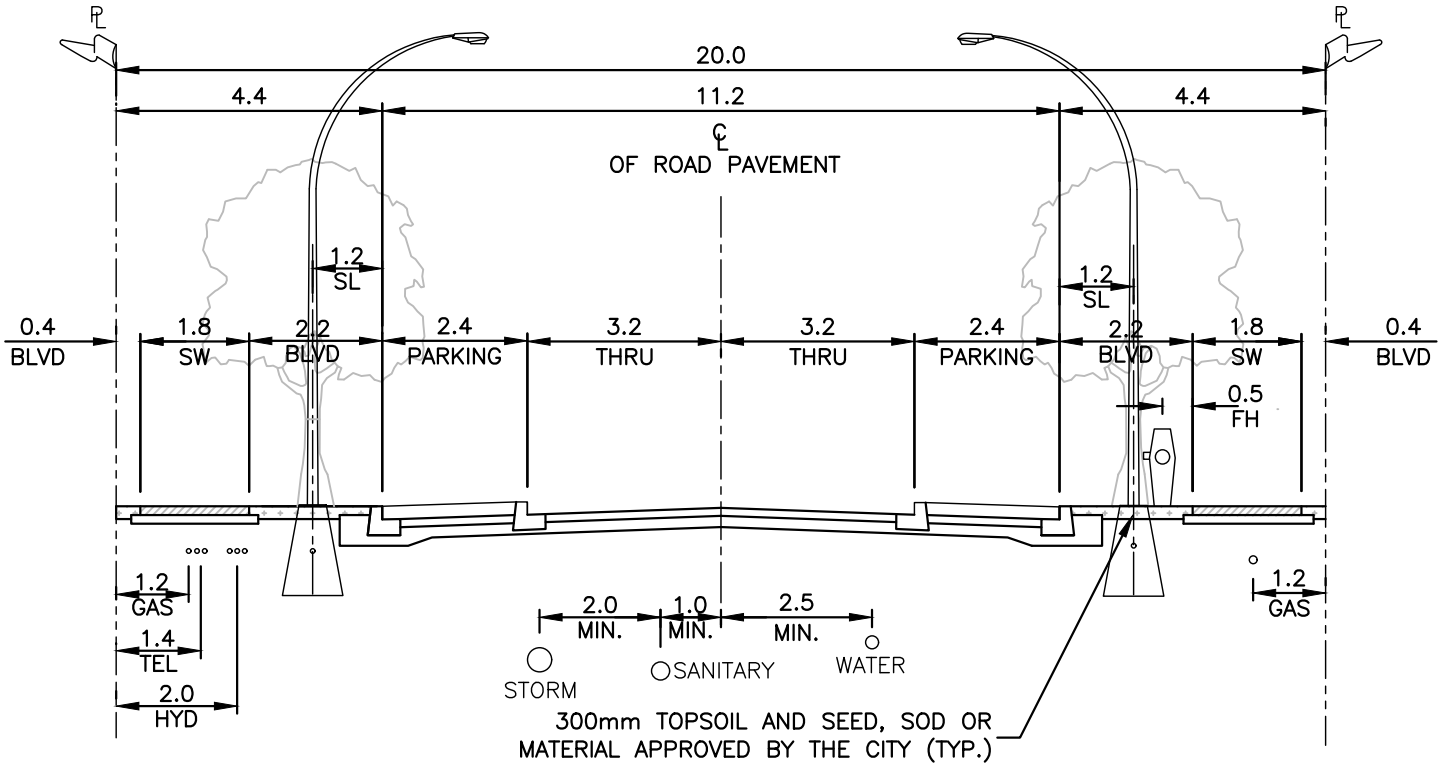

**NOTE:**

1. PAVEMENT MARKINGS TO INCLUDE: CENTRE LINE, BIKE LANES AND TRANSVERSE ROAD MARKINGS TO TAC STANDARD.
2. 3rd PARTY UTILITY DESIGN TO BE PROVIDED BY THE RESPECTIVE UTILITIES.
3. THIS ROAD SECTION ASSUMES NO HYDRO LOADS OR LPT.
4. BULB OUTS TO BE LOCATED AT INTERSECTIONS.
5. TREES TO BE CENTRED IN BOULEVARDS.

NOVEMBER, 2017



**COLLECTOR ROAD SECTION  
URBAN - P**

|                 |                 |
|-----------------|-----------------|
| DRAWING NUMBER  | <b>CSSD CUP</b> |
| REVISION NUMBER | 0               |
| SCALE           | N.T.S.          |

**CITY OF COURTENAY  
SUPPLEMENTARY STANDARD DETAIL DRAWING**

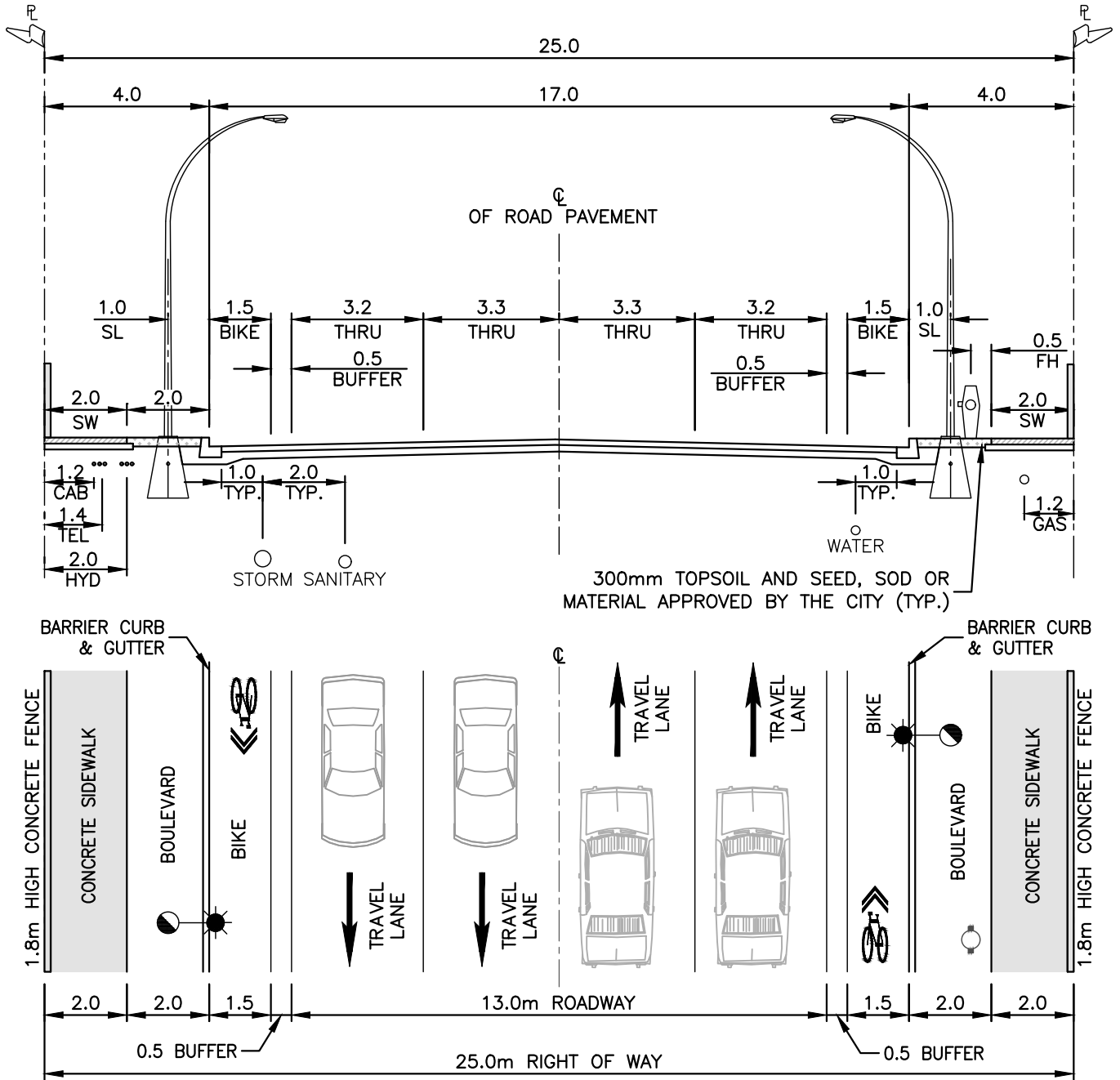

**NOTE:**

1. PAVEMENT MARKINGS TO INCLUDE: CENTRE LINE, THRU LANES, BIKE LANES AND TRANSVERSE ROAD MARKINGS TO TAC STANDARD.
2. BIKE LANE BUFFER TO BE HATCHED / GORE TO TAC STANDARD.
3. 3rd PARTY UTILITY DESIGN TO BE PROVIDED BY THE RESPECTIVE UTILITIES.
4. HYDRO SERVICE BOX TO INCLUDE A STORM SEWER SERVICE CONNECTION AS PER CSSD S8. INSPECTION CHAMBER TO BE LOCATED 300mm FROM SERVICE BOX.

NOVEMBER, 2017



**ARTERIAL ROAD SECTION B**

DRAWING NUMBER

**CSSD AB**

REVISION NUMBER

0

SCALE

N.T.S.

**155**

**CITY OF COURTENAY**  
**SUPPLEMENTARY STANDARD DETAIL DRAWING**

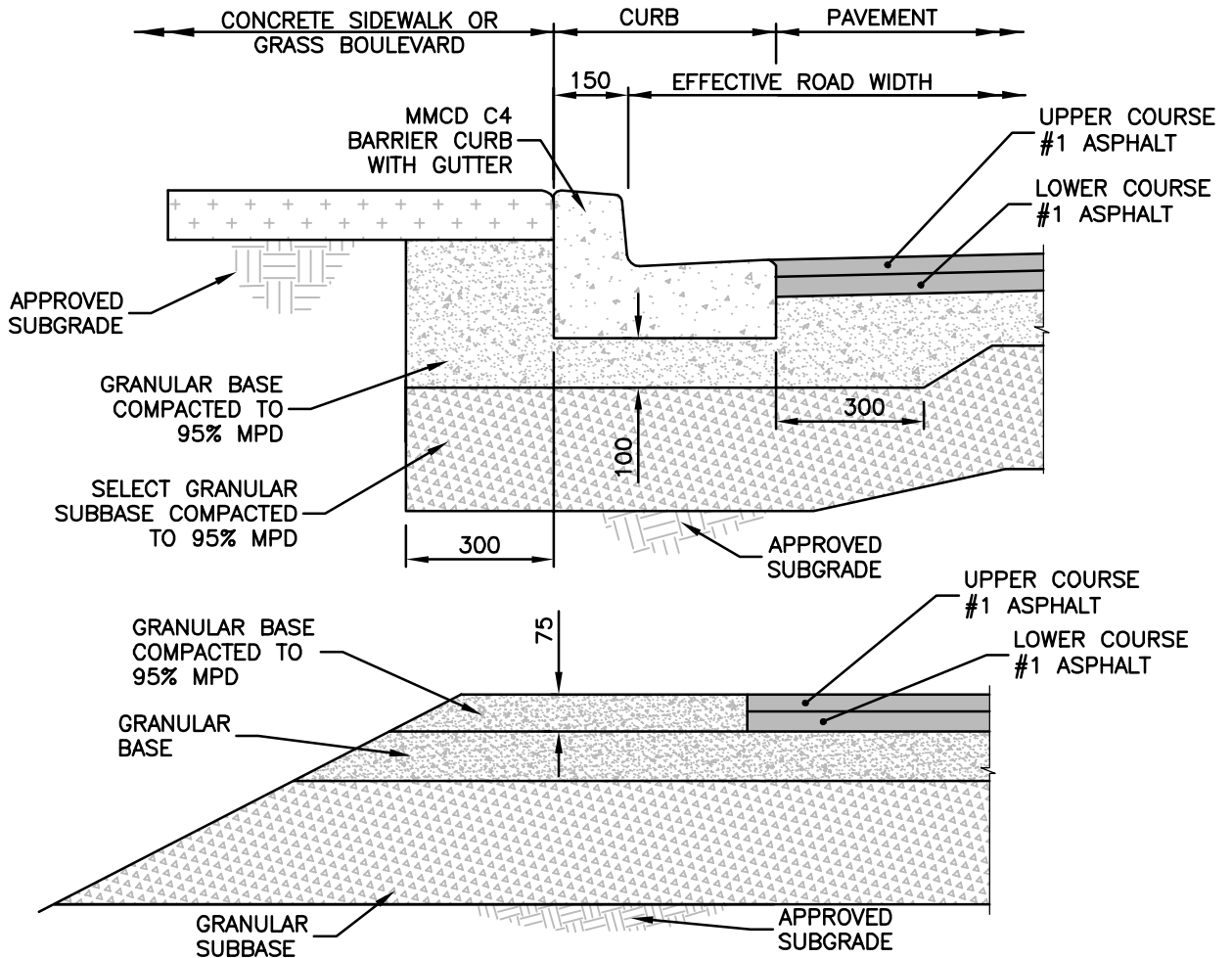

| STANDARD DETAIL | ROAD CLASSIFICATION                     | UPPER COURSE #1 ASPHALT | LOWER COURSE #1 ASPHALT |
|-----------------|---|-------------------------|-------------------------|
| CSSD L1         | LOCAL ROAD SECTION                      | 50                      |                         |
| CSSD CRu        | COLLECTOR ROAD SECTION: RURAL           | 35                      | 40                      |
| CSSD CRe        | COLLECTOR ROAD SECTION: RESIDENTIAL     | 35                      | 40                      |
| CSSD CRB        | COLLECTOR ROAD SECTION: RESIDENTIAL - B | 35                      | 40                      |
| CSSD CRC        | COLLECTOR ROAD SECTION: RESIDENTIAL - C | 50                      | 50                      |
| CSSD CUB        | COLLECTOR ROAD SECTION: URBAN - B       | 35                      | 40                      |
| CSSD CUC        | COLLECTOR ROAD SECTION: URBAN - C       | 50                      | 50                      |
| CSSD CUP        | COLLECTOR ROAD SECTION: URBAN - P       | 50                      | 50                      |
| CSSD AB         | ARTERIAL ROAD SECTION: B                | 50                      | 50                      |
| CSSD A3         | ALTERNATIVE DESIGN STANDARD 3: LANE     | 50                      | N/A                     |

**NOTE:**

1. THE STRUCTURAL ROAD ELEMENTS SHOWN ARE MINIMUM REQUIREMENTS. ROAD STRUCTURE TO BE DESIGNED BASED ON SITE CONDITIONS BY A QUALIFIED GEOTECHNICAL ENGINEER.

MARCH, 2017



**MINIMUM PAVEMENT STRUCTURE REQUIREMENTS**

DRAWING NUMBER

**CSSD R2**

REVISION NUMBER

0

SCALE

N.T.S.  
**156**

CITY OF COURTENAY  
 SUPPLEMENTARY STANDARD DETAIL DRAWING

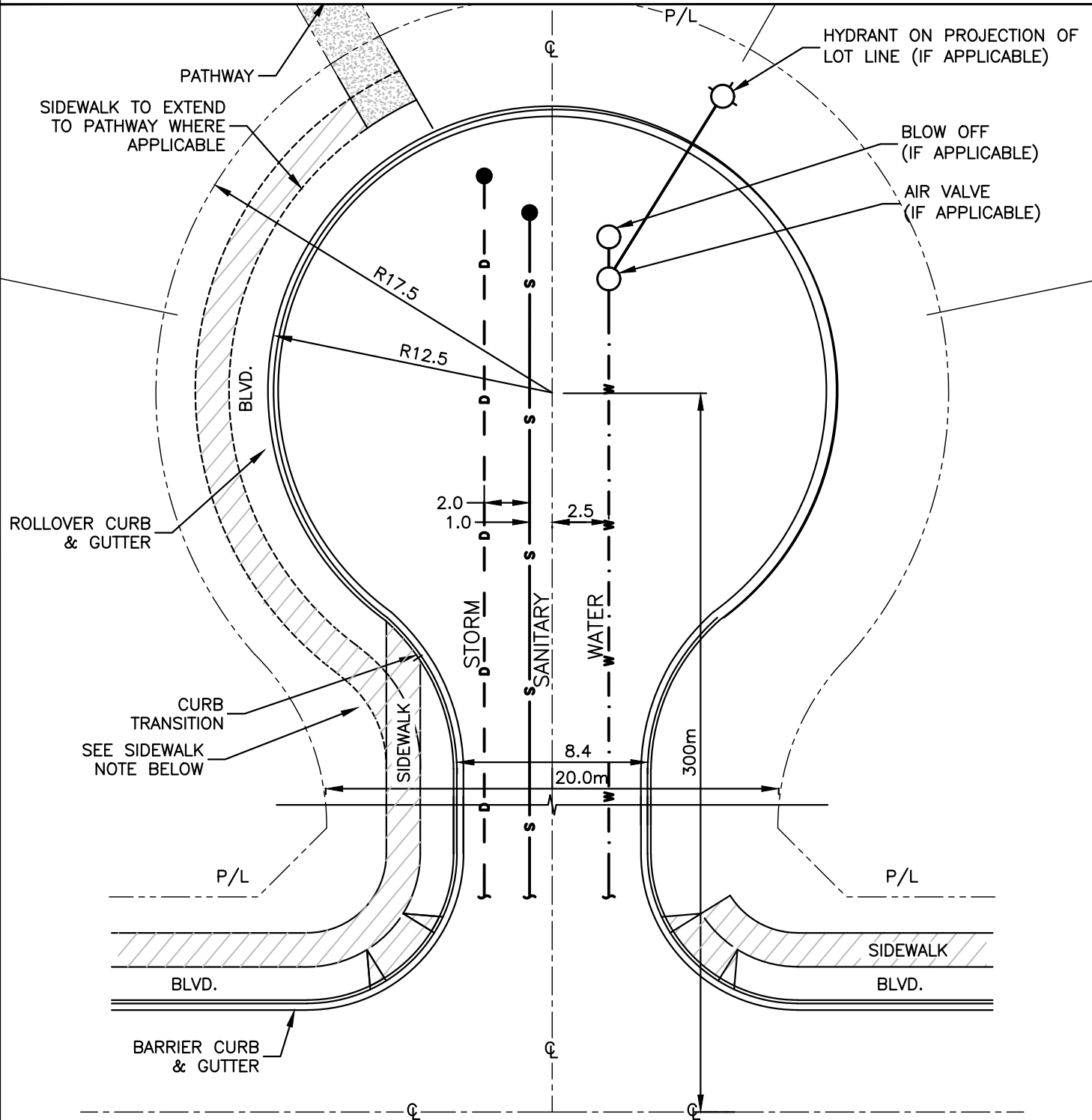

NOTE:

1. CUL-DE-SAC HAVING MORE THAN 10 LOTS INCLUDING THE CORNER LOTS TO BE PROVIDED WITH A SIDEWALK.
2. THE MAXIMUM PERMITTED PROFILE GRADE ON THE TURNAROUND OF A CUL-DE-SAC IS 6%.

NOVEMBER, 2017



CUL-DE-SAC

DRAWING NUMBER

CSSD R3

REVISION NUMBER

0

SCALE

N.T.S.

157

CITY OF COURTENAY  
 SUPPLEMENTARY STANDARD DETAIL DRAWING

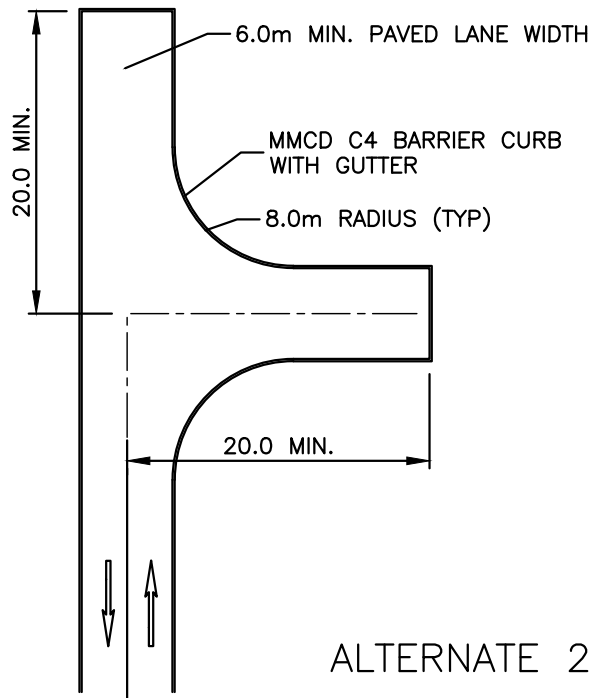
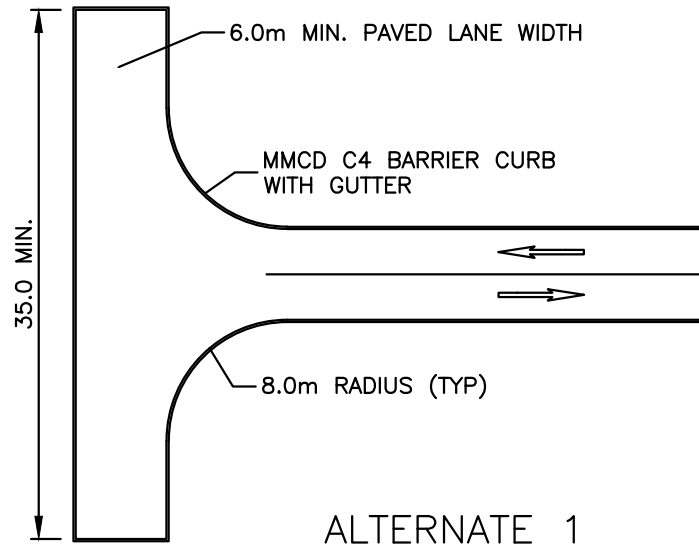

NOTE:

1. ALL DIMENSIONS ARE REQUIRED MINIMUMS

NOVEMBER, 2017



HAMMERHEAD TURNAROUND  
 (PRIVATE ROADS)

DRAWING NUMBER

CSSD R4

REVISION NUMBER

0

SCALE

N.T.S.

158

CITY OF COURTENAY  
 SUPPLEMENTARY STANDARD DETAIL DRAWING

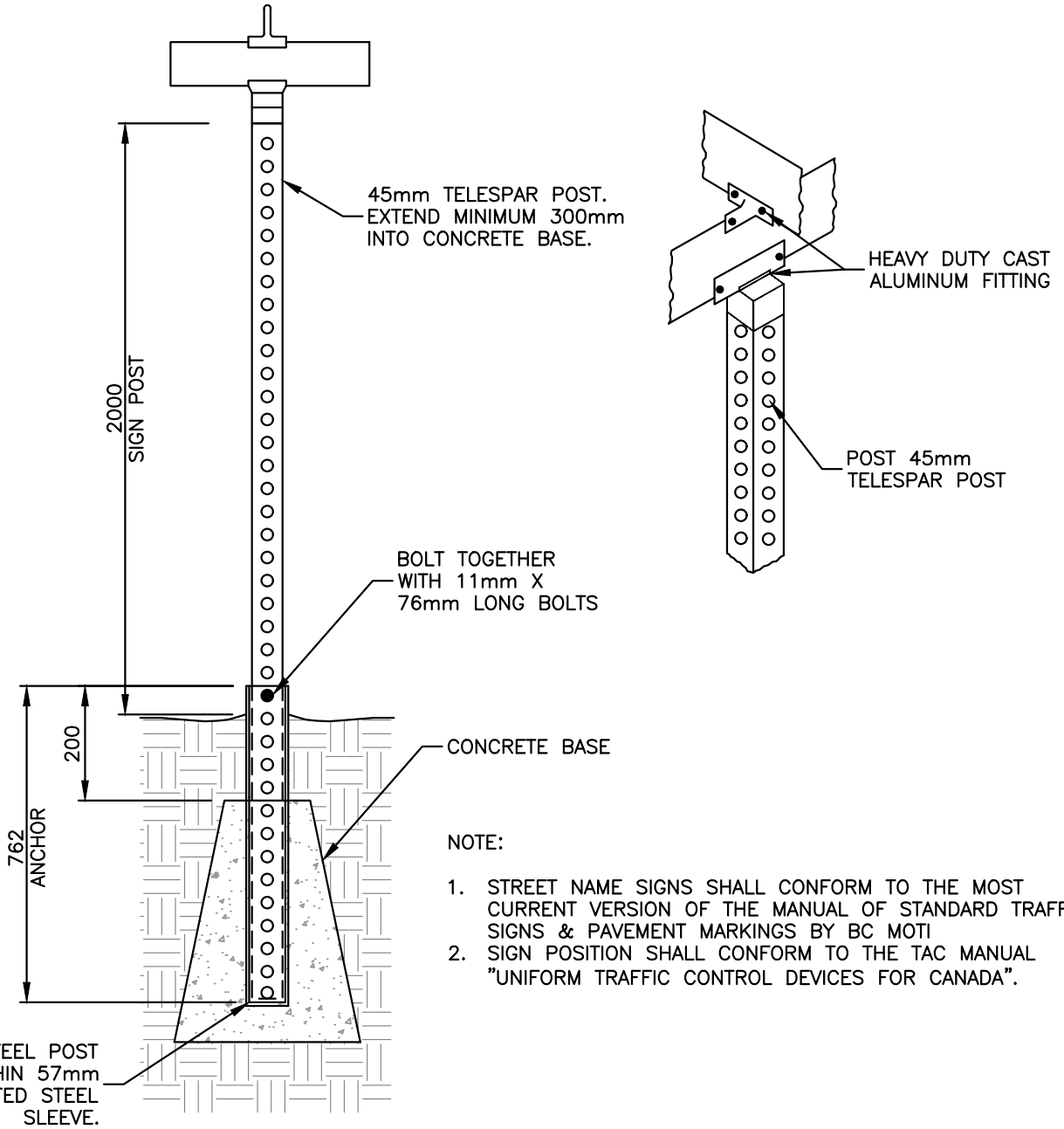

NOVEMBER, 2017



STREET NAME SIGN AND BASE DETAIL

DRAWING NUMBER

CSSD R5

REVISION NUMBER

0

SCALE

N.T.S.

159

**CITY OF COURTENAY  
SUPPLEMENTARY STANDARD DETAIL DRAWING**

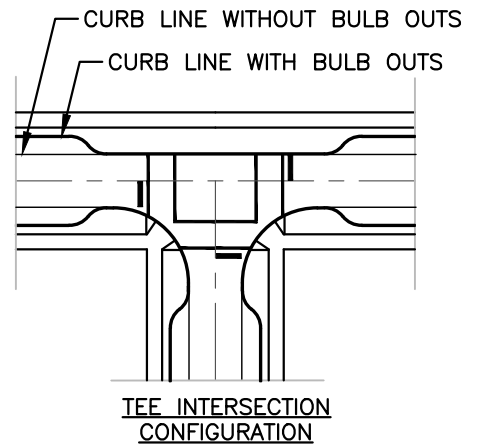
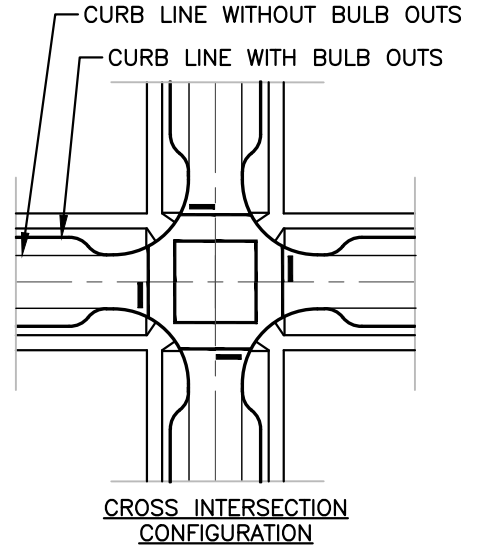
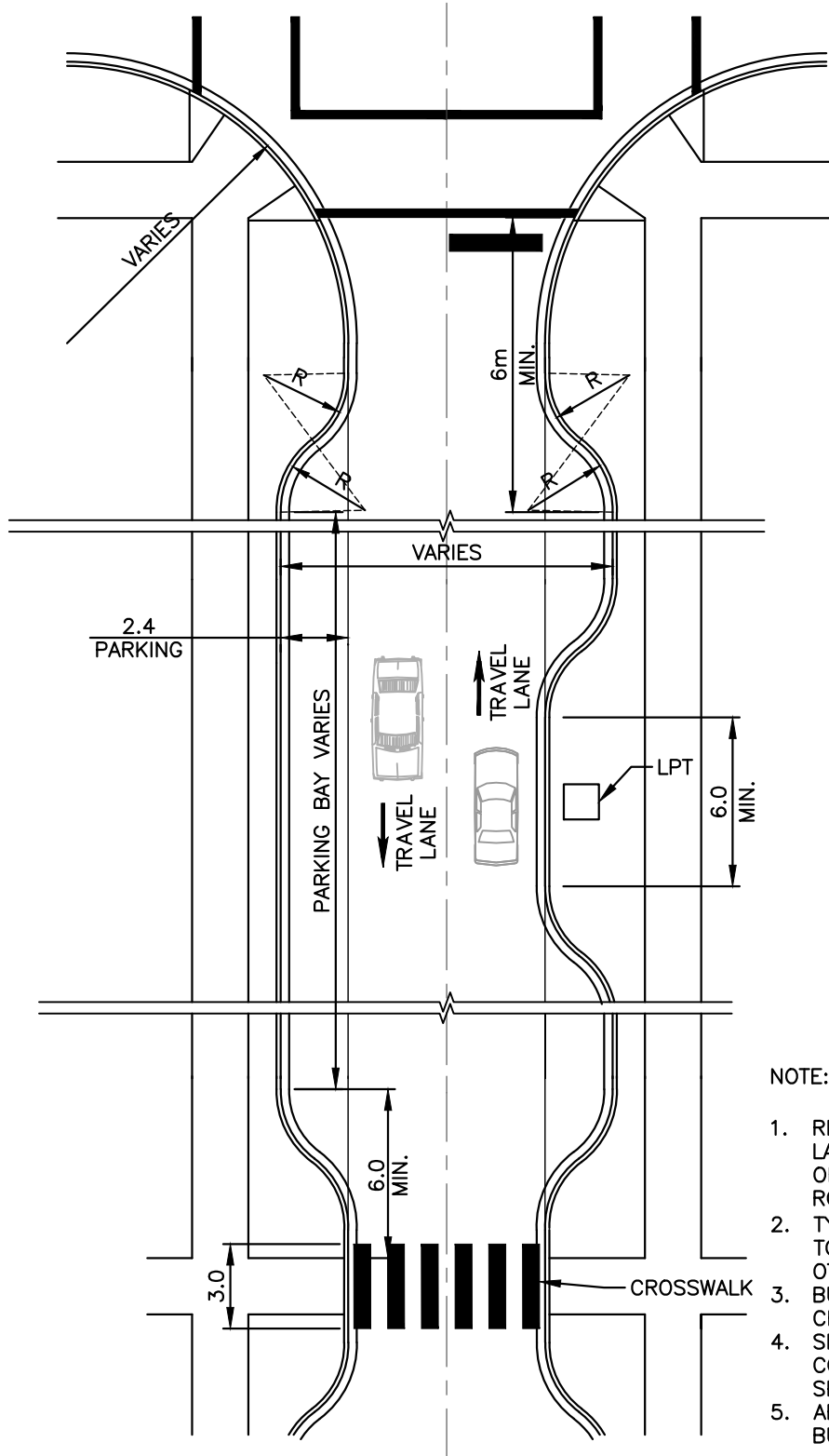

**NOTE:**

1. RIGHT OF WAY WIDTHS, NUMBER OF LANES AND INCLUSION OF BIKE LANES OR BUFFERS VARIES AS PER SPECIFIED ROAD CLASSIFICATION.
2. TYPICAL PARKING BAY FLARE RADII "R" TO BE 3.0m UNLESS SPECIFIED OTHERWISE.
3. BULB-OUT LENGTHS AT MID-BLOCK CROSSWALKS VARIES AS REQUIRED.
4. SIDEWALK & BOULEVARD WIDTHS AND CONFIGURATION VARIES AS PER SPECIFIED ROAD CLASSIFICATION.
5. ARTERIAL ROADWAYS SHALL NOT HAVE BULB OUTS.

NOVEMBER, 2017



**TYPICAL BULB OUT  
LOCATION AND DETAILS**

DRAWING NUMBER

**CSSD R6**

REVISION NUMBER

0

SCALE

N.T.S.  
**160**



**CITY OF COURTENAY  
SUPPLEMENTARY STANDARD DETAIL DRAWING**

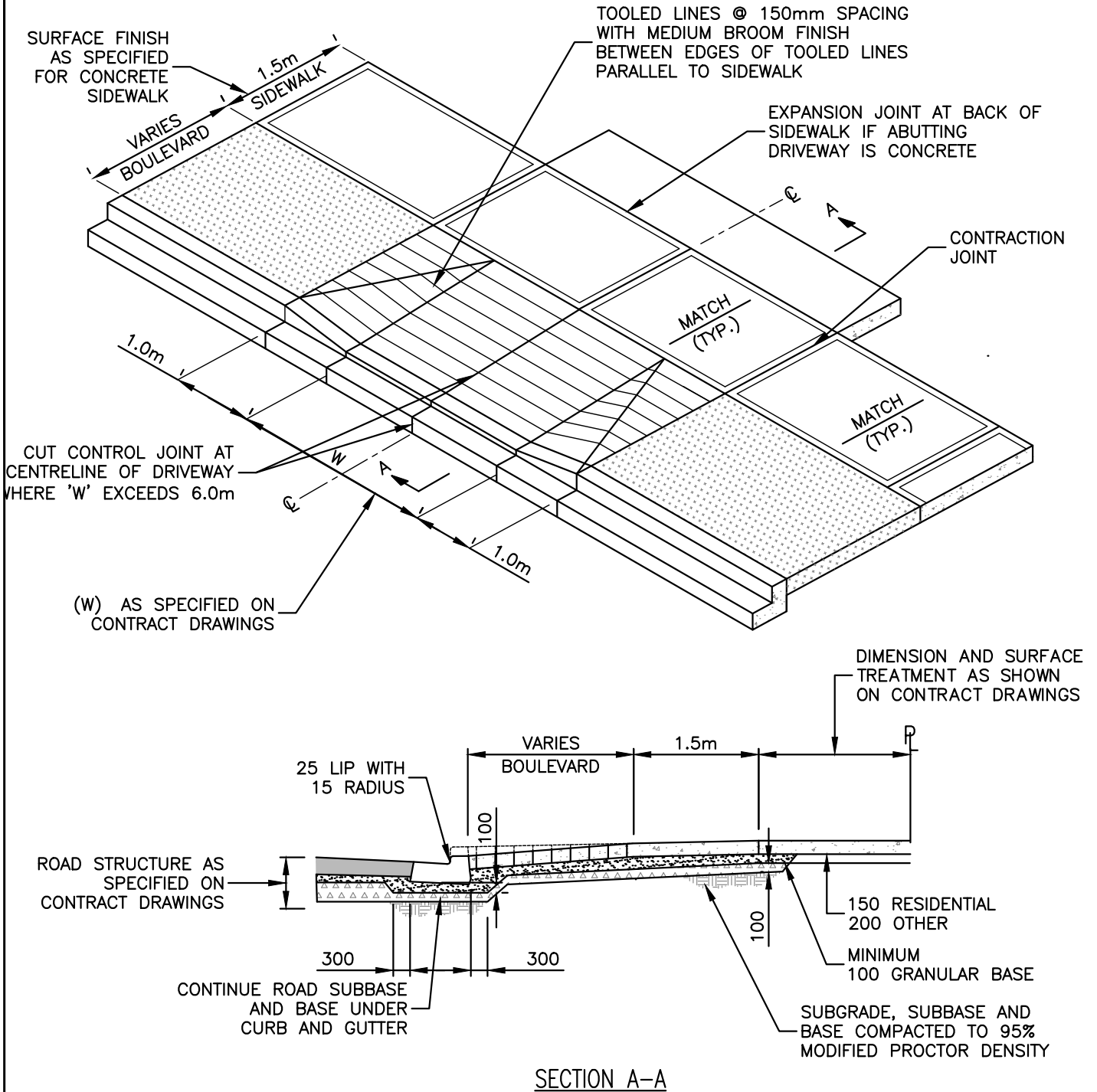

NOTE:

1. DRIVEWAYS ORIENTATED AT 90° TO CURB, UNLESS SPECIFIED OTHERWISE ON CONTRACT DRAWINGS.

NOVEMBER, 2017



**DRIVEWAY CROSSING FOR BARRIER CURBS  
TYPE 2**

DRAWING NUMBER

**CSSD C7b**

REVISION NUMBER

0

SCALE

N.T.S.

**161**

**CITY OF COURTENAY  
SUPPLEMENTARY STANDARD DETAIL DRAWING**

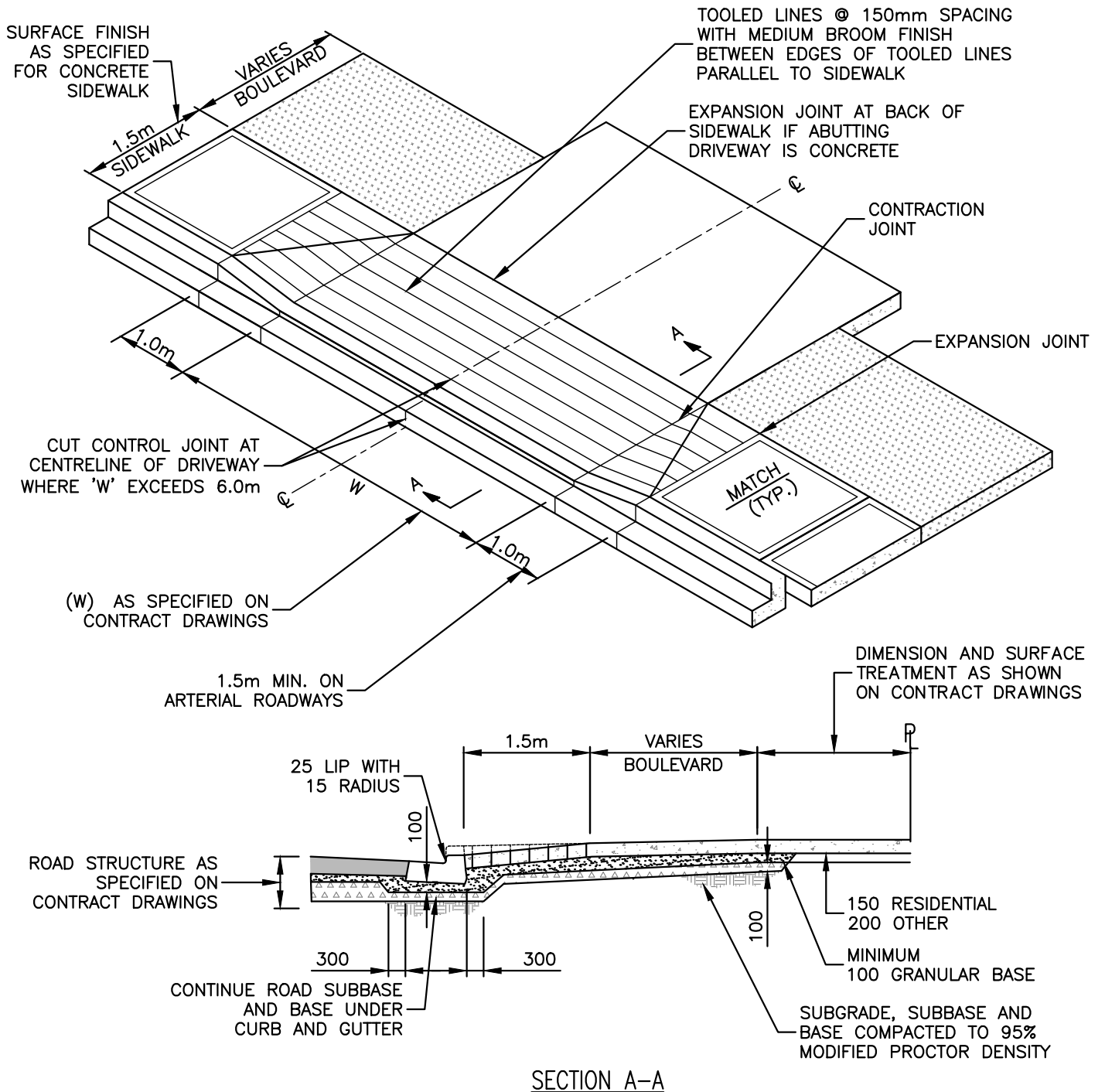

NOTE:

1. DRIVEWAYS ORIENTATED AT 90° TO CURB, UNLESS SPECIFIED OTHERWISE ON CONTRACT DRAWINGS.

NOVEMBER, 2017



**DRIVEWAY CROSSING FOR BARRIER CURBS  
TYPE 3**

DRAWING NUMBER

**CSSD C7c**

REVISION NUMBER

0

SCALE

N.T.S.

**162**



**CITY OF COURTENAY  
SUPPLEMENTARY STANDARD DETAIL DRAWING**

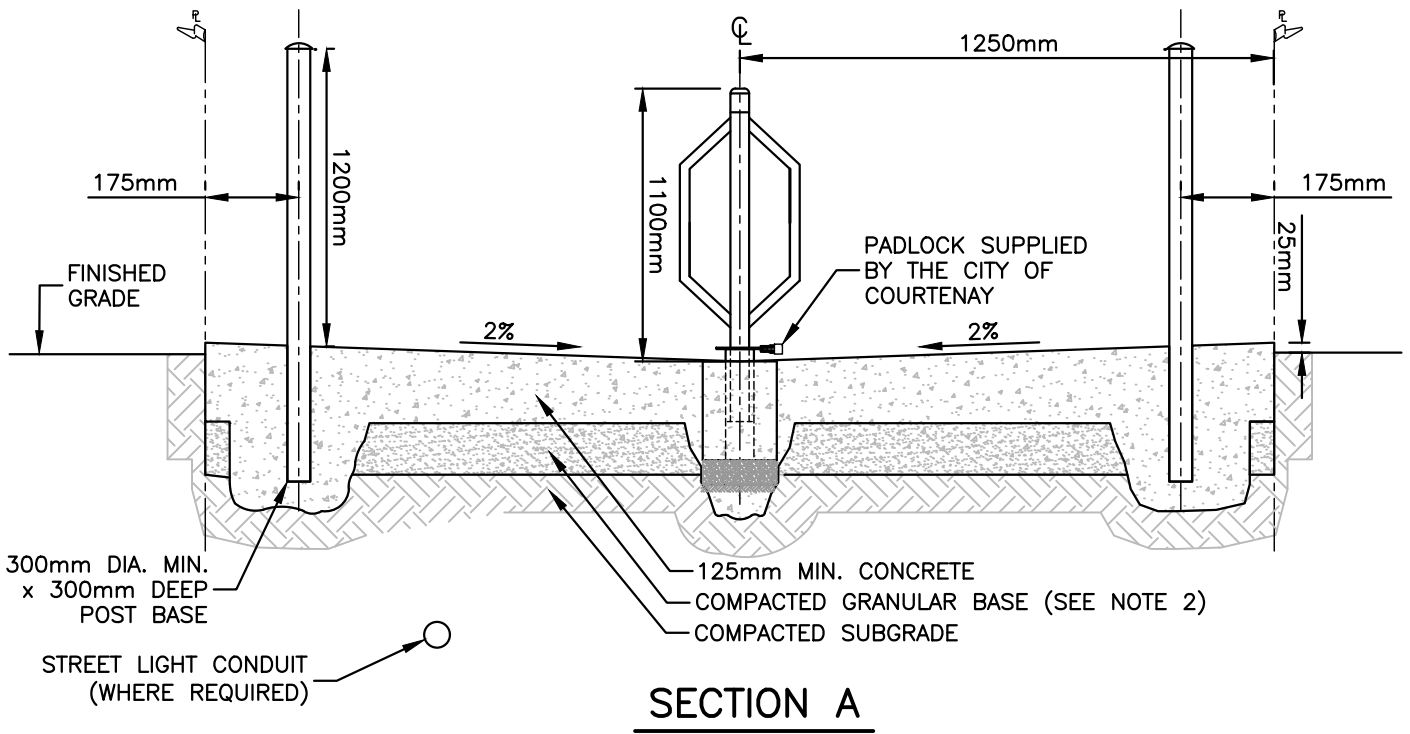
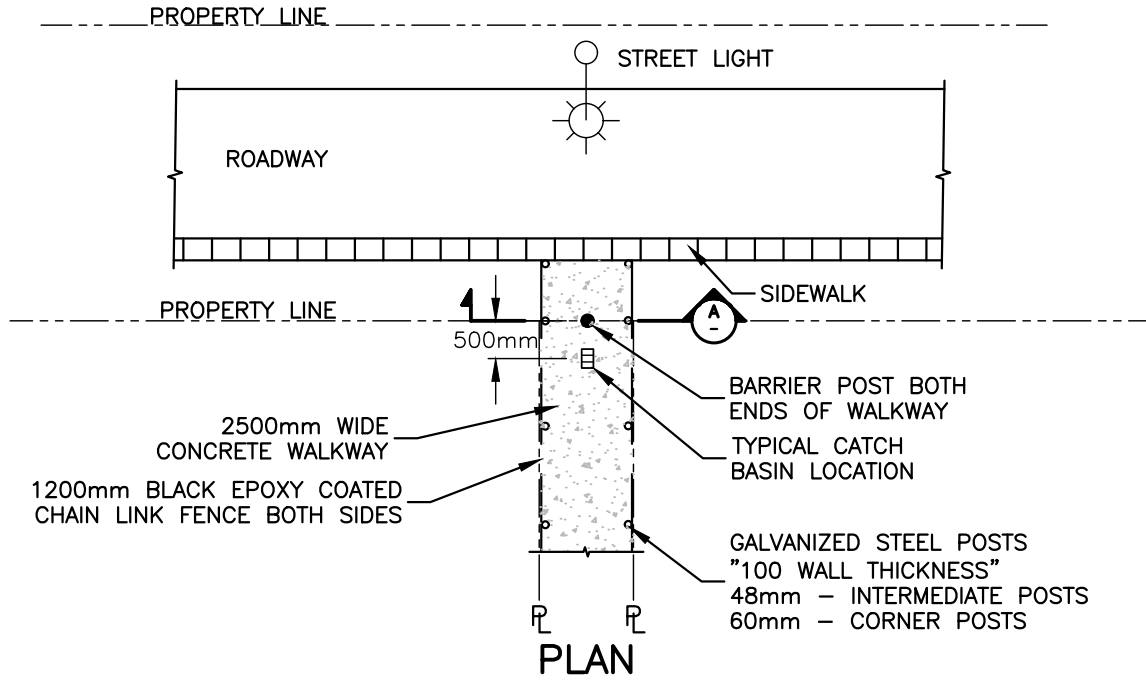

**NOTE:**

1. THE STRUCTURAL WALKWAY ELEMENTS SHOWN ARE MINIMUM REQUIREMENTS. WALKWAY STRUCTURE TO BE DESIGNED BASED ON SITE CONDITIONS BY A QUALIFIED GEOTECHNICAL ENGINEER.
2. CONCRETE THICKNESS TO BE 150mm MINIMUM WHEN WALKWAY USED TO ACCESS UTILITIES. GRANULAR BASE THICKNESS TO BE DETERMINED BY QUALIFIED GEOTECHNICAL ENGINEER.

FEBRUARY, 2016



**CONCRETE WALKWAY**

DRAWING NUMBER

**CSSD C10**

REVISION NUMBER

0

SCALE

N.T.S.

**164**

**CITY OF COURTENAY  
SUPPLEMENTARY STANDARD DETAIL DRAWING**

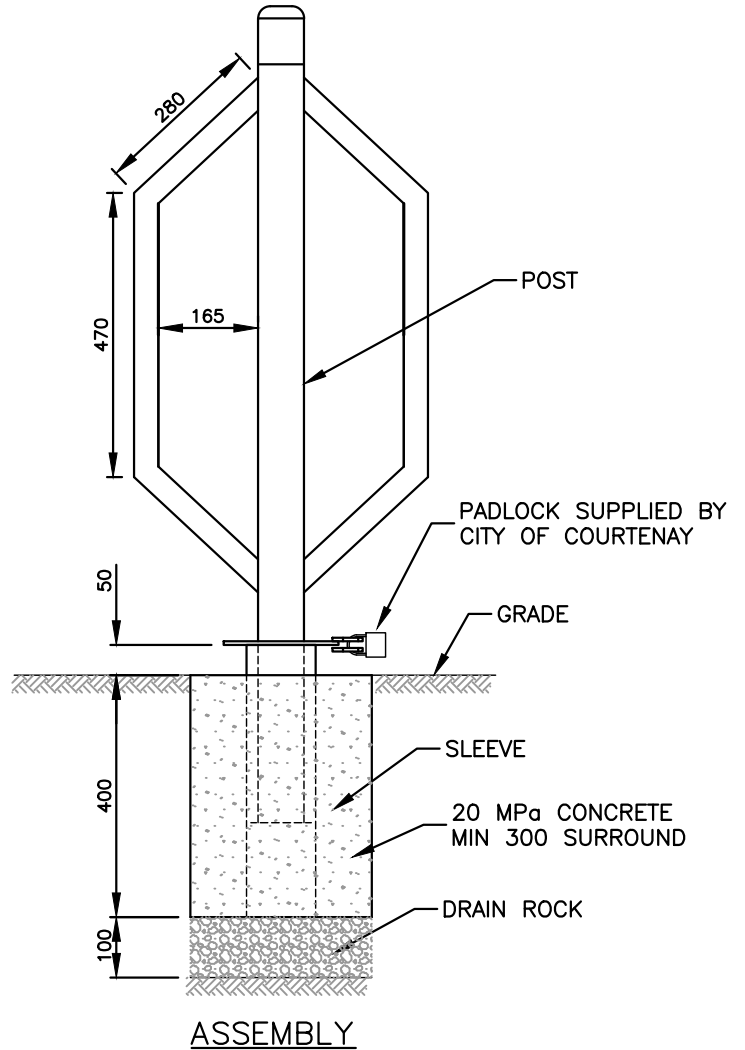
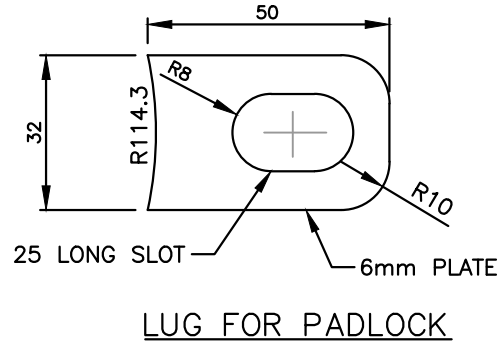
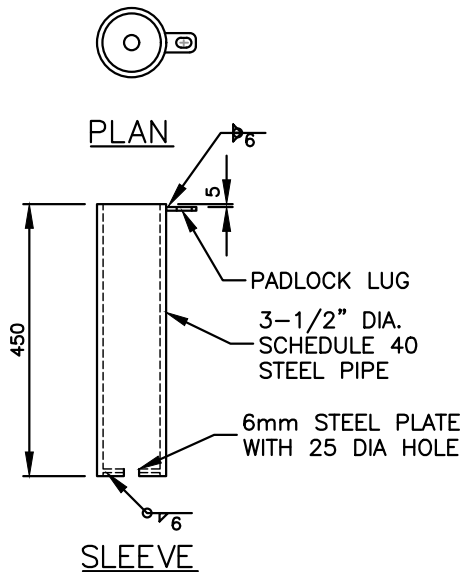
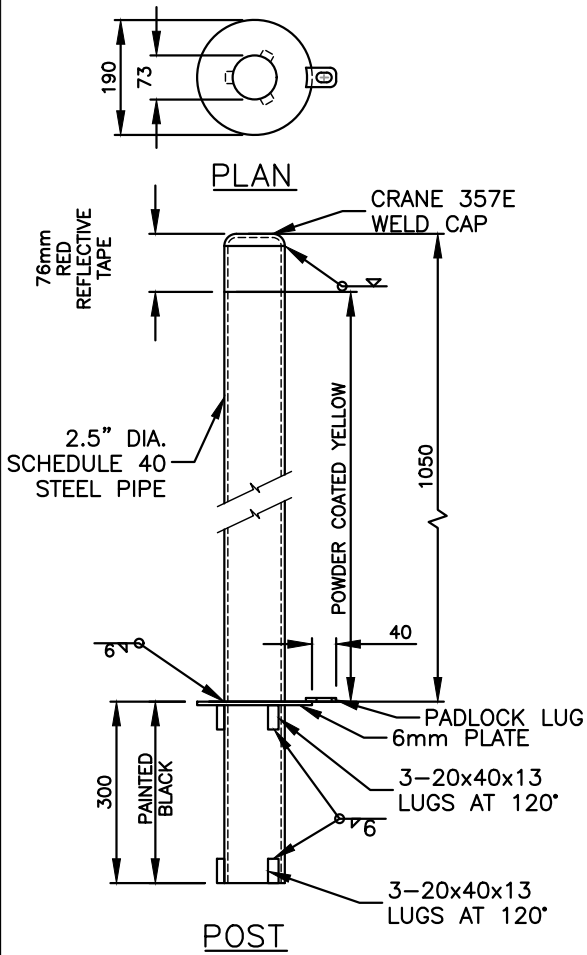

NOTE:

1. FOR USE ON MULTI-USE PATHWAYS AND TRAILS WHEN NECESSARY TO PREVENT VEHICLE ACCESS.
2. ALL DIMENSIONS IN MILLIMETERS UNLESS OTHERWISE NOTED.

NOVEMBER, 2017



**REMOVABLE BOLLARD**

DRAWING NUMBER

**CSSD C12**

REVISION NUMBER

0

SCALE

N.T.S.

**165**

**CITY OF COURTENAY**  
**SUPPLEMENTARY STANDARD DETAIL DRAWING**

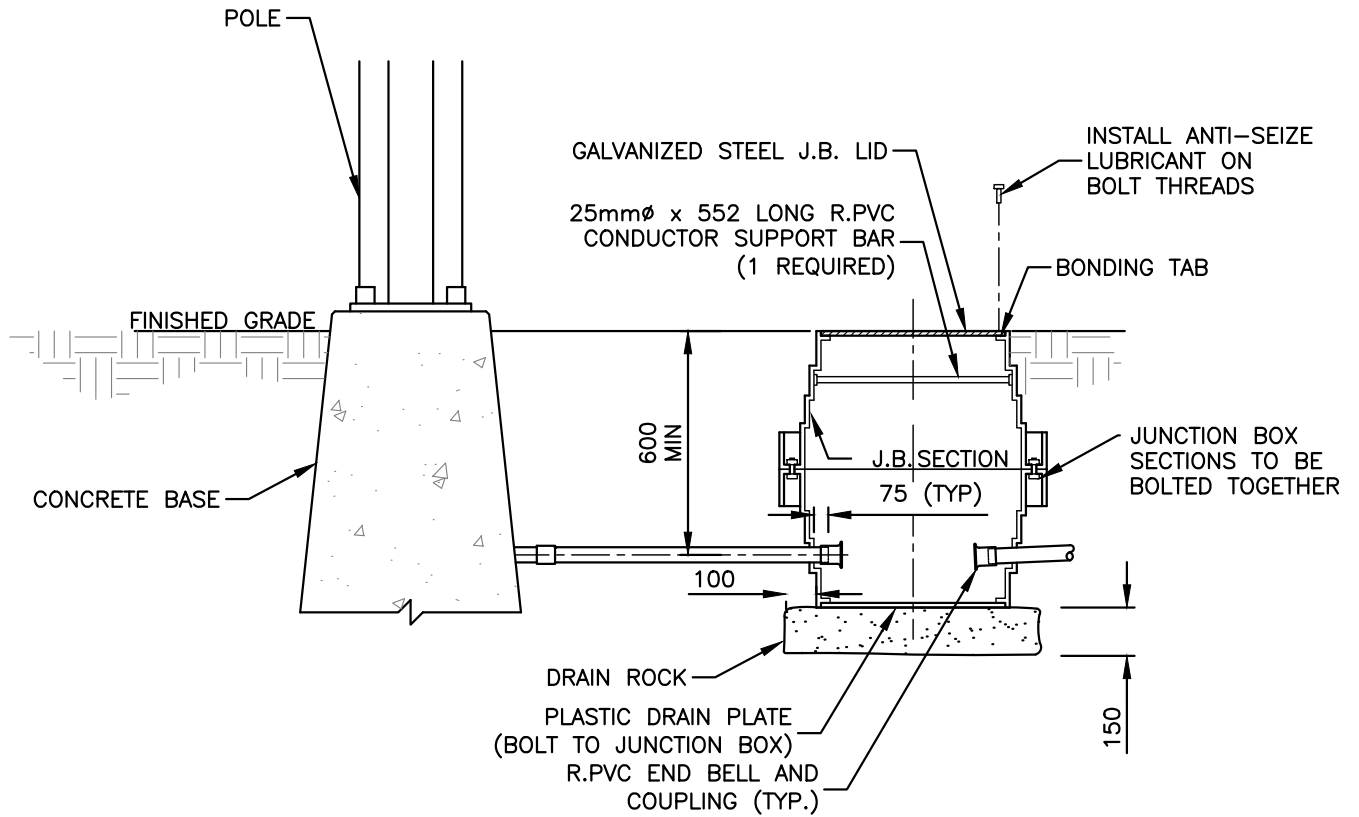

JUNCTION BOX

TWO J.B. SECTIONS  
 ONE STEEL LID  
 ONE DRAIN PLATE

NOTE:

1. REFER TO CONTRACT DRAWINGS, SECTION 34 41 13 FOR DETAILED SPECIFICATIONS.
2. BOLT DOWN LID ON BOX BEFORE BACKFILLING, TAMPING & PAVING OPERATIONS.
3. INSTALL TOP OF JUNCTION BOX FLUSH WITH FINISHED GRADE.
4. ALL CONDUITS SHALL DRAIN TO J.B.'S
5. ALL DIMENSIONS ARE IN MILLIMETRES UNLESS OTHERWISE NOTED.

NOVEMBER, 2017



**ROUND PLASTIC JUNCTION BOXES**

DRAWING NUMBER

**CSSD E2.1**

REVISION NUMBER

0

SCALE

N.T.S.

**166**

**CITY OF COURTENAY**  
**SUPPLEMENTARY STANDARD DETAIL DRAWING**

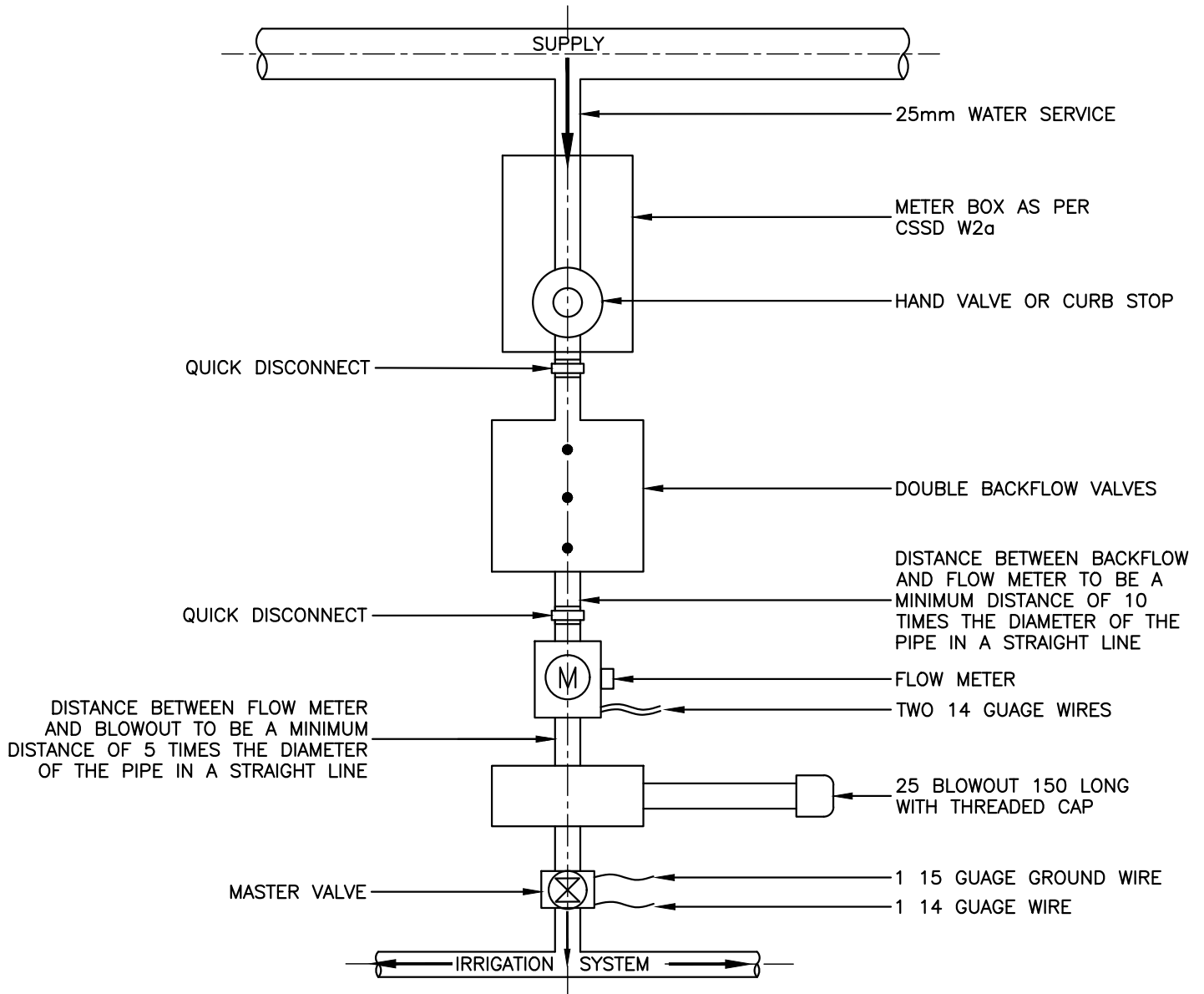

**NOTE:**

1. 25X150 RISER WITH THREADED CAP FOR BLOWOUT.
2. BACKFLOW VALVE DOUBLE CHECK.
3. (760X450X450) RECTANGULAR BOX.
4. TWO QUICK DISCONNECT COUPLERS FOR BACKFLOW REMOVAL.
5. 14 GAUGE T.W.U. WIRE FOR CONNECTION TO CONTROLLER.
6. ALL DIMENSIONS ARE IN MILLIMETRES UNLESS OTHERWISE INDICATED.

NOVEMBER, 2017



**IRRIGATION CONNECTION**

DRAWING NUMBER

**CSSD 11**

REVISION NUMBER

0

SCALE

N.T.S.

**167**

CITY OF COURTENAY  
 SUPPLEMENTARY STANDARD DETAIL DRAWING

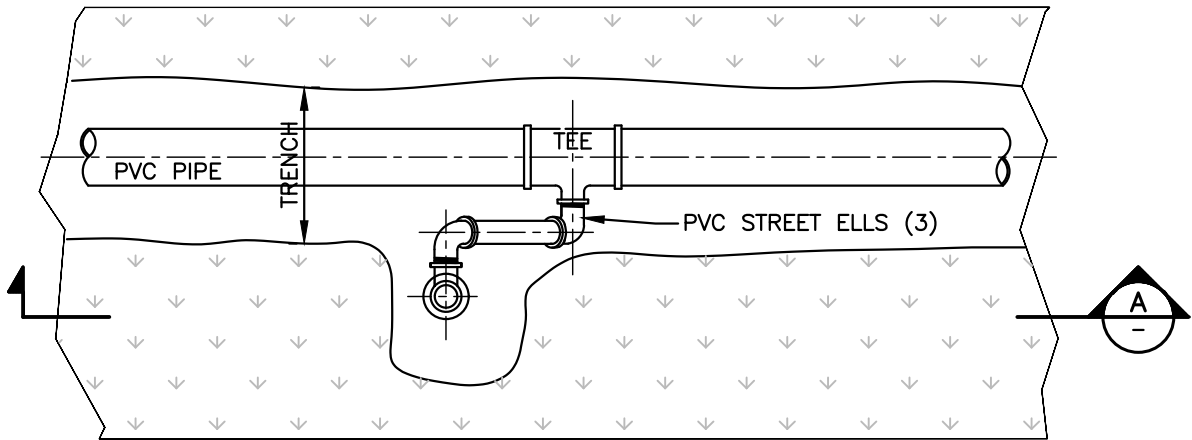

PLAN

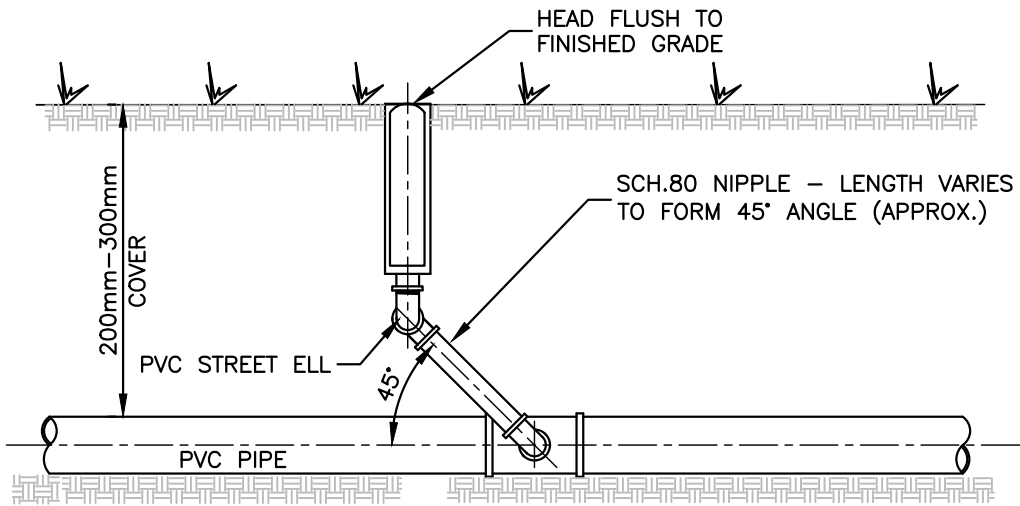

SECTION A

NOTE:

1. USE TEFLON TAPE ON ALL MALE THREADED ENDS

NOVEMBER, 2017



IRRIGATION SWING JOINT

DRAWING NUMBER

CSSD 12

REVISION NUMBER

0

SCALE

N.T.S.

168



**CITY OF COURTENAY  
SUPPLEMENTARY STANDARD DETAIL DRAWING**

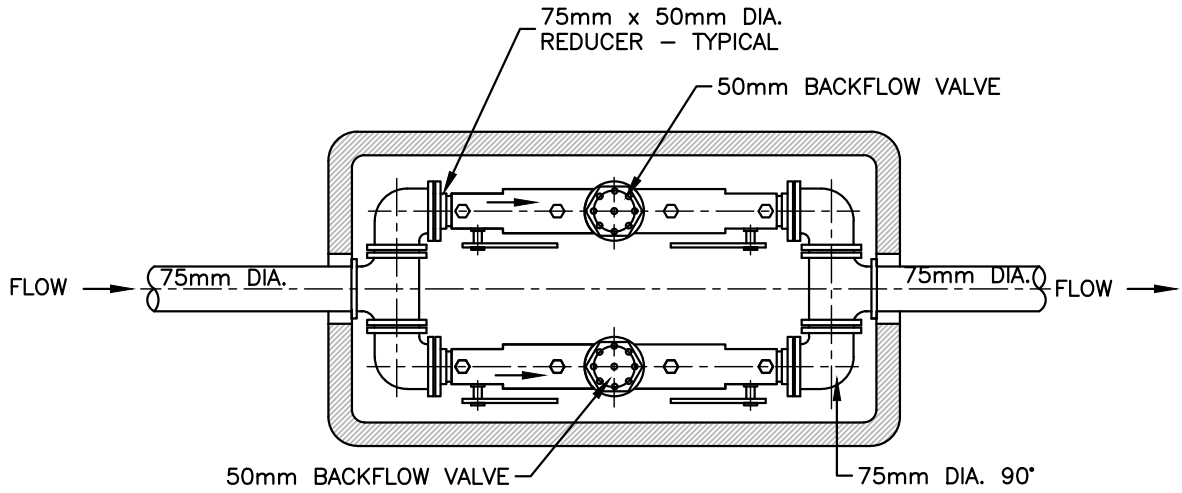

**TYPICAL LARGE LINE/TWIN BACKFLOW VALVES**

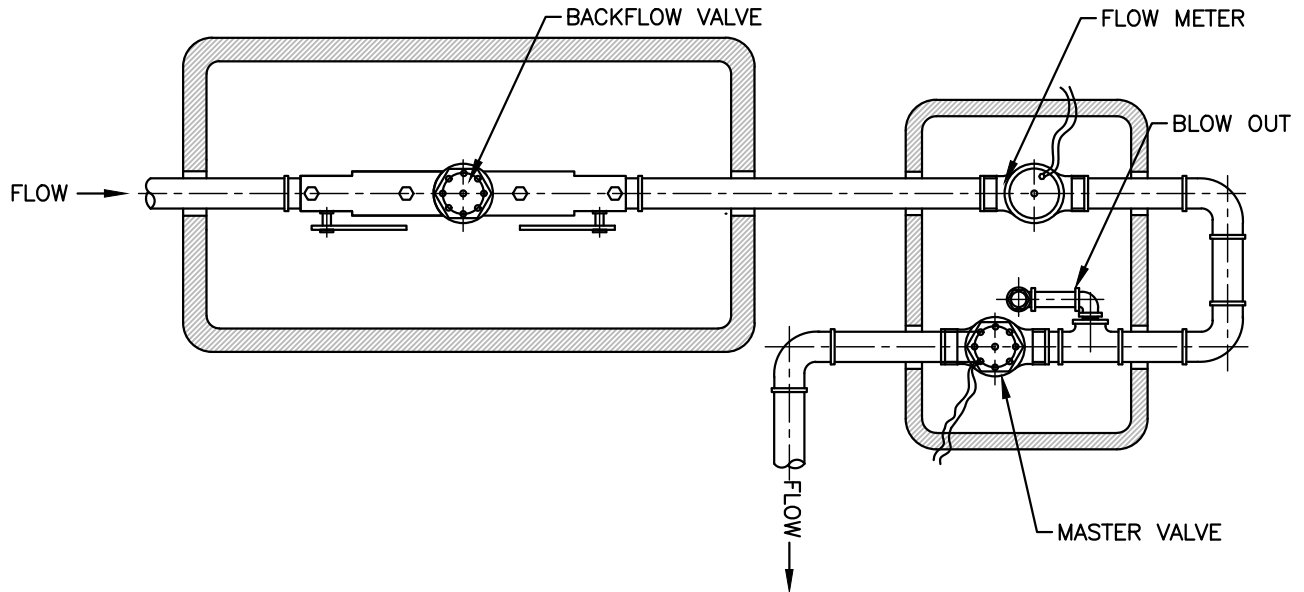

**TYPICAL MASTER VALVE/FLOW METER**

NOTE:

1. FLOW METER TO HAVE 10x PIPE DIA. BEFORE AND 5x PIPE DIA. AFTER, OF UNRESTRICTED STRAIGHT PIPE (OF THE SAME DIAMETER, NO FITTINGS) EACH SIDE OF METER.
2. FLOW METER TO BE DISASSEMBLED PRIOR TO GLUING OF PIPE.

NOVEMBER, 2017



**TYPICAL INSTALLATIONS  
LARGE LINE / TWIN BACKFLOW VALVES  
MASTER VALVE / FLOW METER**

DRAWING NUMBER

**CSSD 13**

REVISION NUMBER

0

SCALE

N.T.S.  
**169**

**CITY OF COURTENAY  
SUPPLEMENTARY STANDARD DETAIL DRAWING**

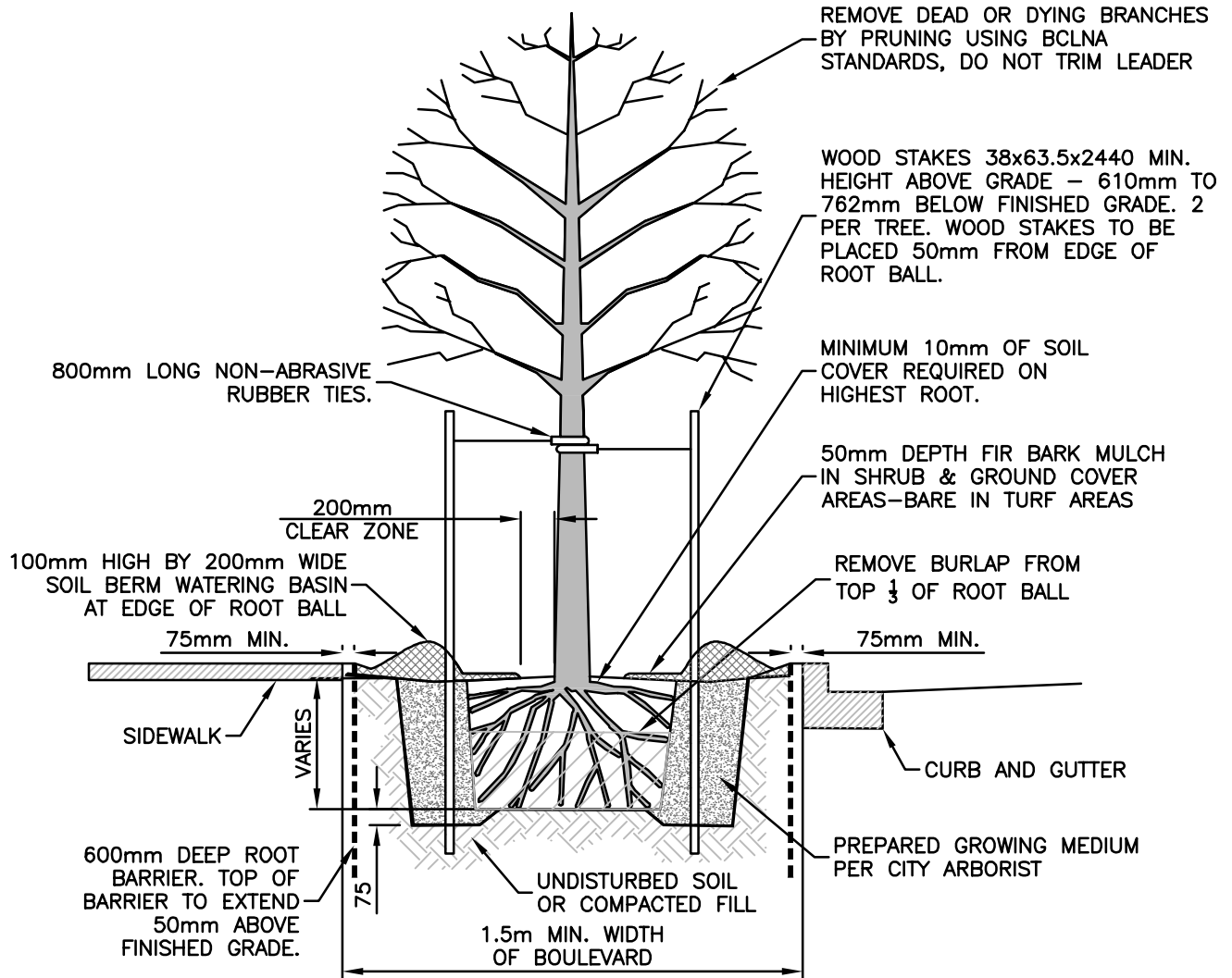

**NOTE:**

1. PLACE TREE & BACKFILL 50mm ABOVE GRADE TO ALLOW FOR SETTLEMENT.
2. ROOT BARRIERS SHALL BE INSTALLED WHEN ROOT BALL IS LOCATED WITHIN 2.44m OF PAVEMENT.
3. ROOT BARRIERS TO EXTEND 2.44m IN BOTH DIRECTIONS FROM TREE CENTRE LINE.
4. ALL DIMENSIONS ARE IN MILLIMETRES UNLESS OTHERWISE INDICATED.

**TREE PLANTING  
AND STAKING**

DRAWING NUMBER

**CSSD P1**

REVISION NUMBER

0

SCALE

N.T.S.  
**170**



**CITY OF COURTENAY  
SUPPLEMENTARY STANDARD DETAIL DRAWING**

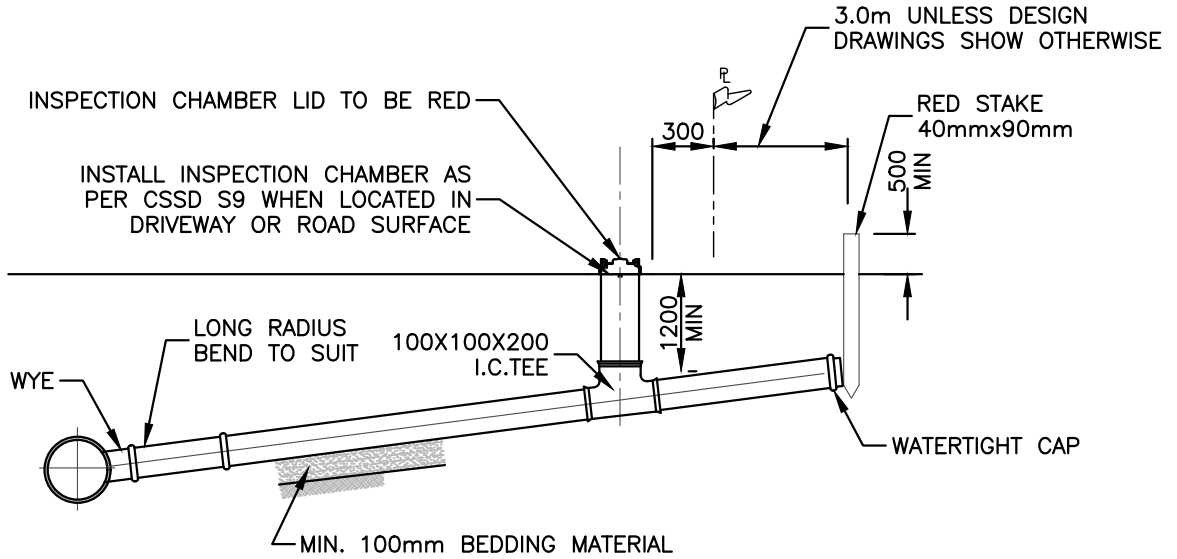

**SERVICE CONNECTION**

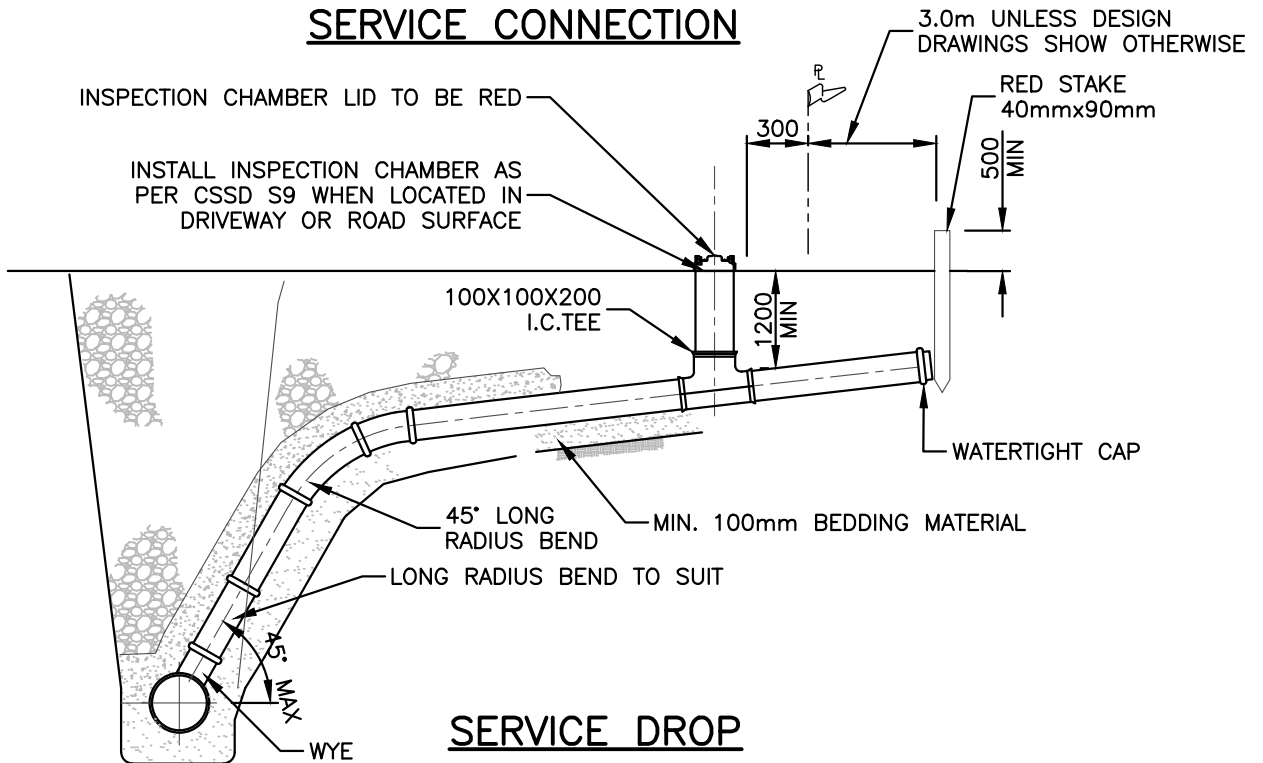

**SERVICE DROP**

NOTE:

1. SERVICE CONNECTIONS TO BE LONG LENGTHS OF PVC WITH AS FEW JOINTS AS POSSIBLE.
2. FOR LARGER SERVICE CONNECTIONS, REFER TO CONTRACT DRAWINGS
3. SANITARY SERVICE TO HAVE A MINIMUM GRADE OF 2%.
4. THE CONTRACTOR IS TO VIDEO INSPECT ALL SANITARY SERVICE CONNECTIONS. THE VIDEO MUST BE REVIEWED AND ACCEPTED BY THE ENGINEER OF RECORD PRIOR TO COMMENCEMENT OF ASPHALT PAVING.
5. BEDDING AND BACKFILL AS PER MMCD DRAWING G4.
6. DEVELOPER TO INSTALL INSPECTION CHAMBER 300mm ABOVE ESTIMATED GRADE. THE CITY WILL ADJUST THE INSPECTION CHAMBER ONCE THE FINAL LANDSCAPE GRADE HAS BEEN DETERMINED.

NOVEMBER, 2017



**SANITARY SEWER SERVICE CONNECTION  
100mm RESIDENTIAL SANITARY**

DRAWING NUMBER

**CSSD S7**

REVISION NUMBER

0

SCALE

N.T.S.

171

**CITY OF COURTENAY  
SUPPLEMENTARY STANDARD DETAIL DRAWING**

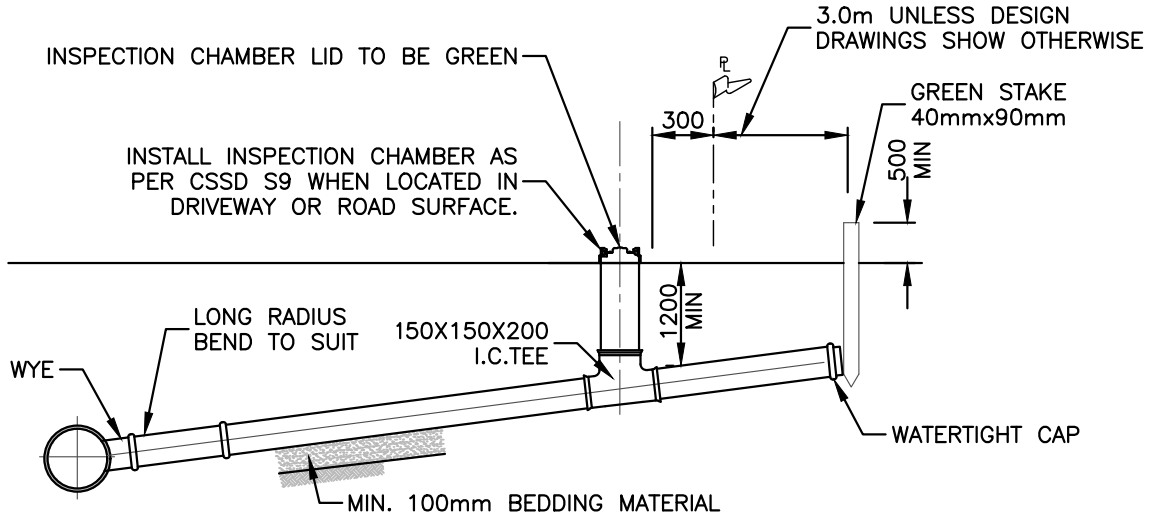

**SERVICE CONNECTION**

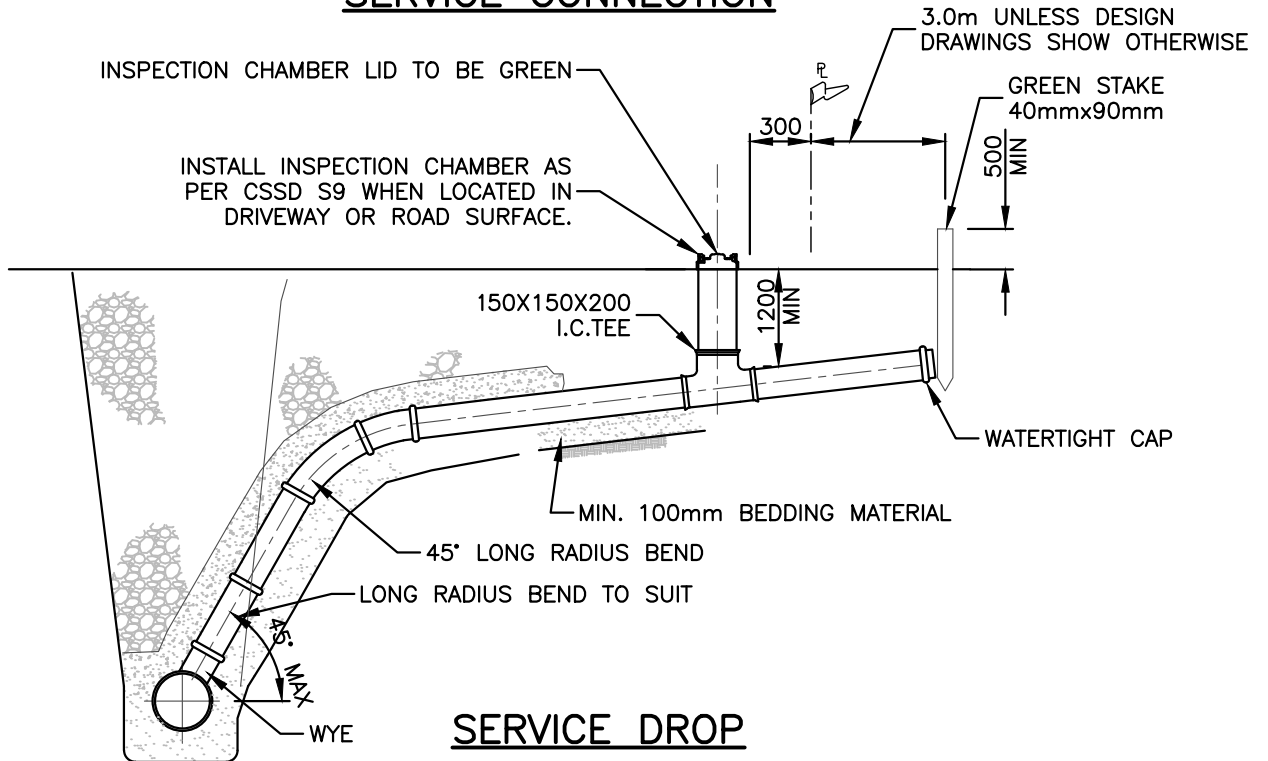

**SERVICE DROP**

NOTE:

1. CONCRETE STORM SEWER PIPES TO BE PROVIDED WITH SUPPLIER INSTALLED PVC STUB.
2. SERVICE CONNECTIONS TO BE LONG LENGTHS OF PVC WITH AS FEW JOINTS AS POSSIBLE.
3. STORM SERVICE TO HAVE MINIMUM GRADE OF 2%.
4. MINIMUM SIZE OF SERVICE CONNECTION: 150mm.
5. THE CONTRACTOR IS TO VIDEO INSPECT ALL STORM SERVICE CONNECTIONS. THE VIDEO MUST BE REVIEWED AND ACCEPTED BY THE ENGINEER OF RECORD PRIOR TO COMMENCEMENT OF ASPHALT PAVING.
6. BEDDING AND BACKFILL AS PER MMCD DRAWING G4.
7. DEVELOPER TO INSTALL INSPECTION CHAMBER 300mm ABOVE ESTIMATED GRADE. THE CITY WILL ADJUST THE INSPECTION CHAMBER ONCE THE FINAL LANDSCAPING GRADE HAS BEEN DETERMINED.

NOVEMBER, 2017



**STORM SEWER SERVICE CONNECTION  
150mm RESIDENTIAL STORM**

DRAWING NUMBER

**CSSD S8**

REVISION NUMBER

0

SCALE

N.T.S.  
**172**

**CITY OF COURTENAY  
SUPPLEMENTARY STANDARD DETAIL DRAWING**

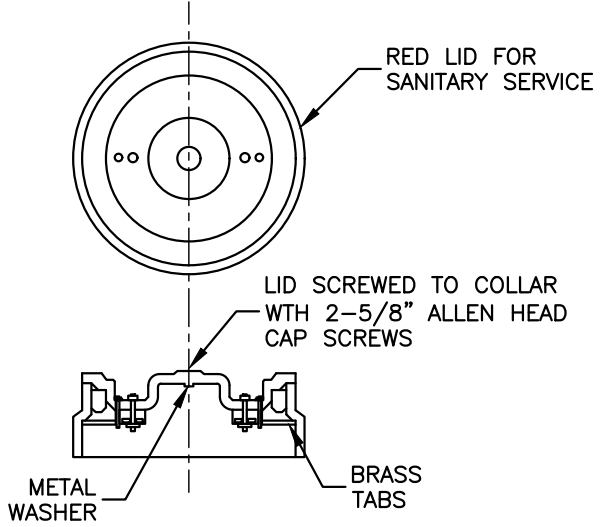
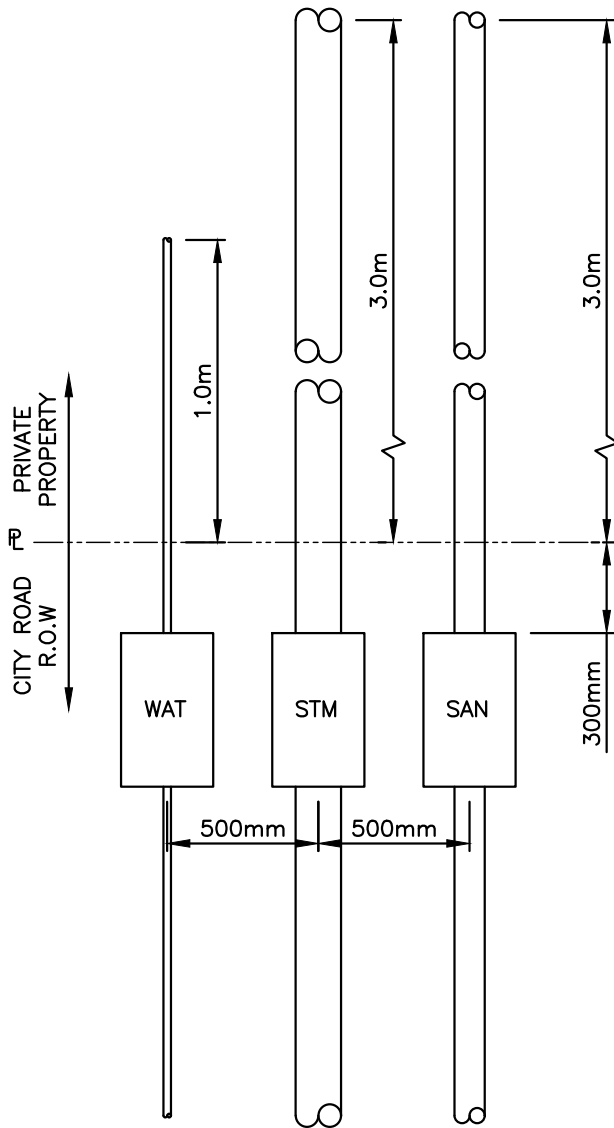

**LID DETAIL**

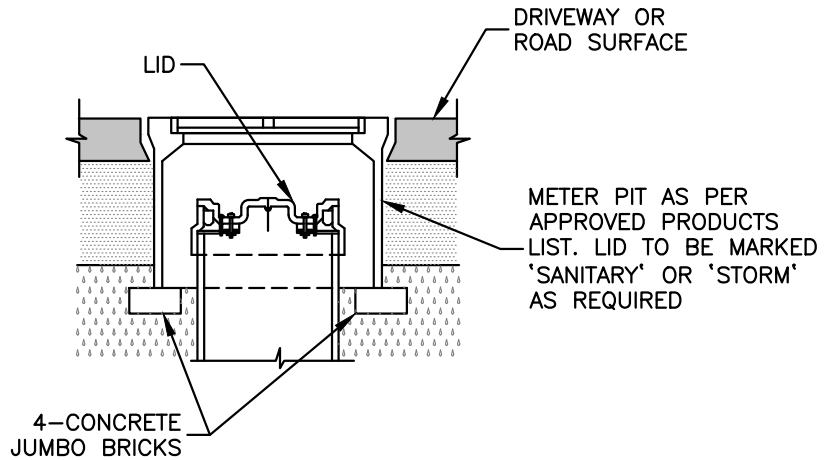

**INSPECTION CHAMBER  
DETAIL**

**NOTE:**

1. REFER TO DRAWING CSSD S7 AND CSSD S8 FOR INSTALLATION REQUIREMENTS.
2. INSPECTION CHAMBER TO BE APPROVED MANUFACTURED FITTING.
3. REFER TO CONTRACT DRAWINGS FOR SITE SPECIFIC DIMENSIONS. REFER TO SECTION 33 30 01 FOR DETAILED SPECIFICATIONS.
4. SANITARY AND STORM SERVICES TO BE EXTENDED 3.0m INTO PROPERTY UNLESS DRAWINGS SHOW OTHERWISE.
5. SERVICES TO BE LOCATED A DISTANCE OF  $\frac{1}{3}$  THE LOT WIDTH FROM THE PROPERTY LINE ON THE OPPOSITE SIDE AS THE DRIVEWAY.

NOVEMBER, 2017



**INSPECTION CHAMBER FOR  
SANITARY AND STORM SEWER CONNECTIONS**

DRAWING NUMBER

**CSSD S9**

REVISION NUMBER

0

SCALE

N.T.S.  
**173**

**CITY OF COURTENAY**  
**SUPPLEMENTARY STANDARD DETAIL DRAWING**

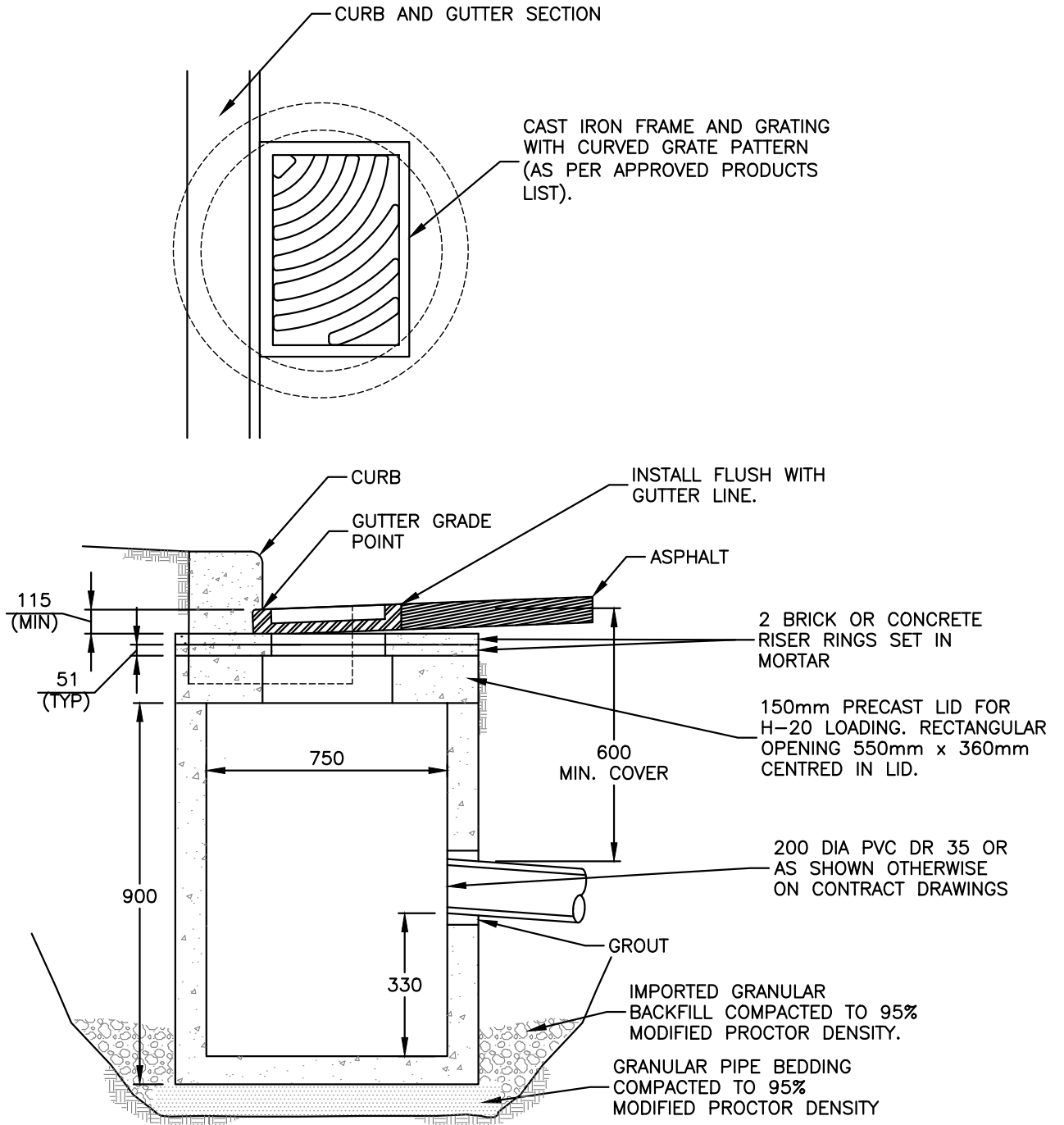

**NOTE:**

1. PRECAST UNITS c/w BASE AND H-20 RATING, APPROVED BY CONTRACT ADMINISTRATOR, ARE ACCEPTABLE.
2. REFER TO CONTRACT DRAWINGS, SECTION 33 44 01 FOR DETAILED SPECIFICATIONS.
3. ALL DIMENSIONS IN MILLIMETRES UNLESS OTHERWISE SHOWN.

NOVEMBER, 2017



**TOP INLET CATCH BASIN**

DRAWING NUMBER

**CSSD S11**

REVISION NUMBER

0

SCALE

N.T.S.

**174**

**CITY OF COURTENAY  
SUPPLEMENTARY STANDARD DETAIL DRAWING**

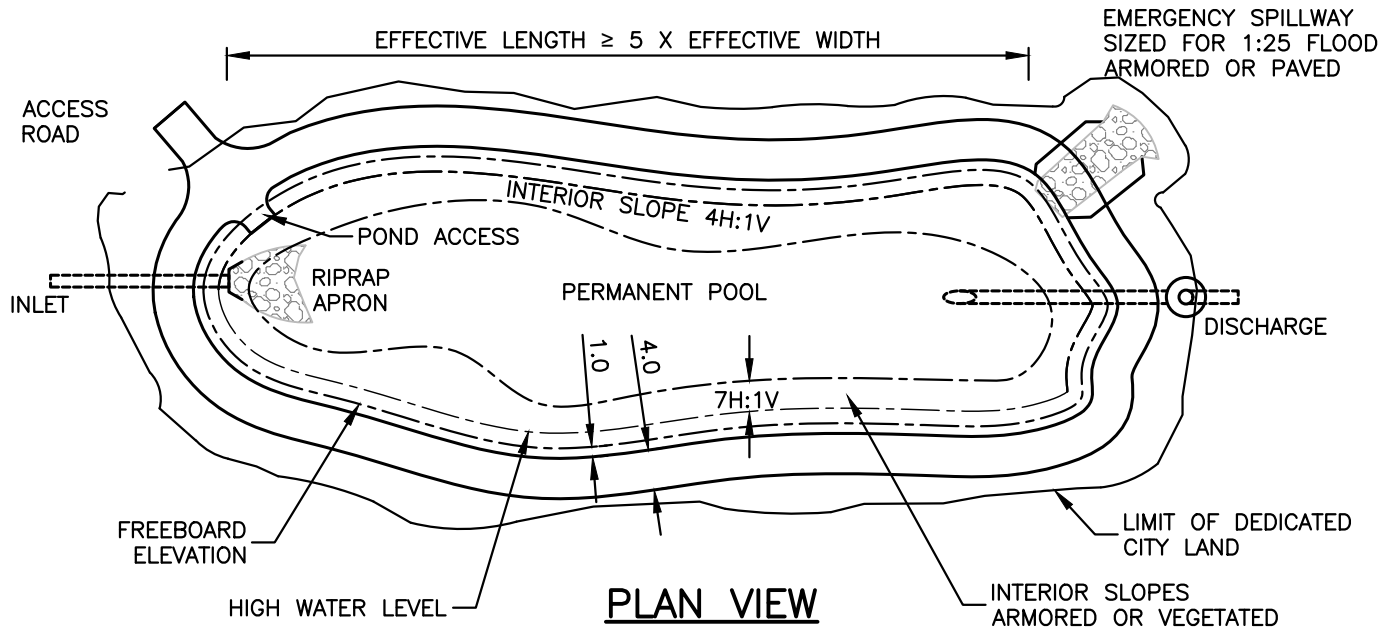

**PLAN VIEW**

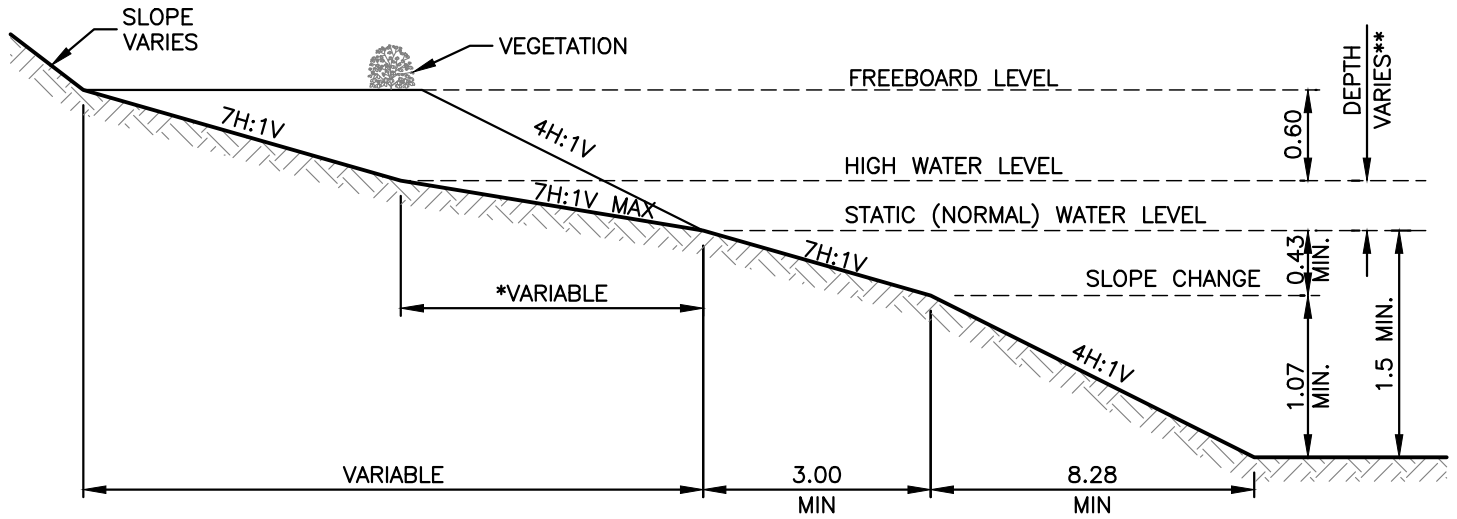

**SECTION VIEW**

NOTE:

- \*MAXIMUM SIDE SLOPES OF 4:1 (H:V) MAY BE USED PROVIDED ADEQUATE VEGETATION IS USED TO PREVENT ACCESS, OR FOR DRY POND SIDE SLOPES.
- \*\*MAXIMUM 1.5m FOR  $\leq 10$  YEAR LEVEL AND 3.0m FOR THE 25 YEAR LEVEL.
- PERMANENT POOL BOTTOM SHALL INCLUDE FULL WIDTH BAFFLES TO DEVELOP SEDIMENTATION BASINS IF APPLICABLE.
- DEPTHS ABOVE WET POND STATIC (NORMAL) WATER LEVEL SHALL ALSO APPLY TO DRY PONDS.
- ALL DIMENSIONS ARE IN METRES.

NOVEMBER, 2017



**WET DETENTION POND  
PLAN AND SECTION**

|                 |               |
|-----------------|---------------|
| DRAWING NUMBER  | CSSD S16      |
| REVISION NUMBER | 0             |
| SCALE           | N.T.S.<br>175 |

CITY OF COURTENAY  
 SUPPLEMENTARY STANDARD DETAIL DRAWING

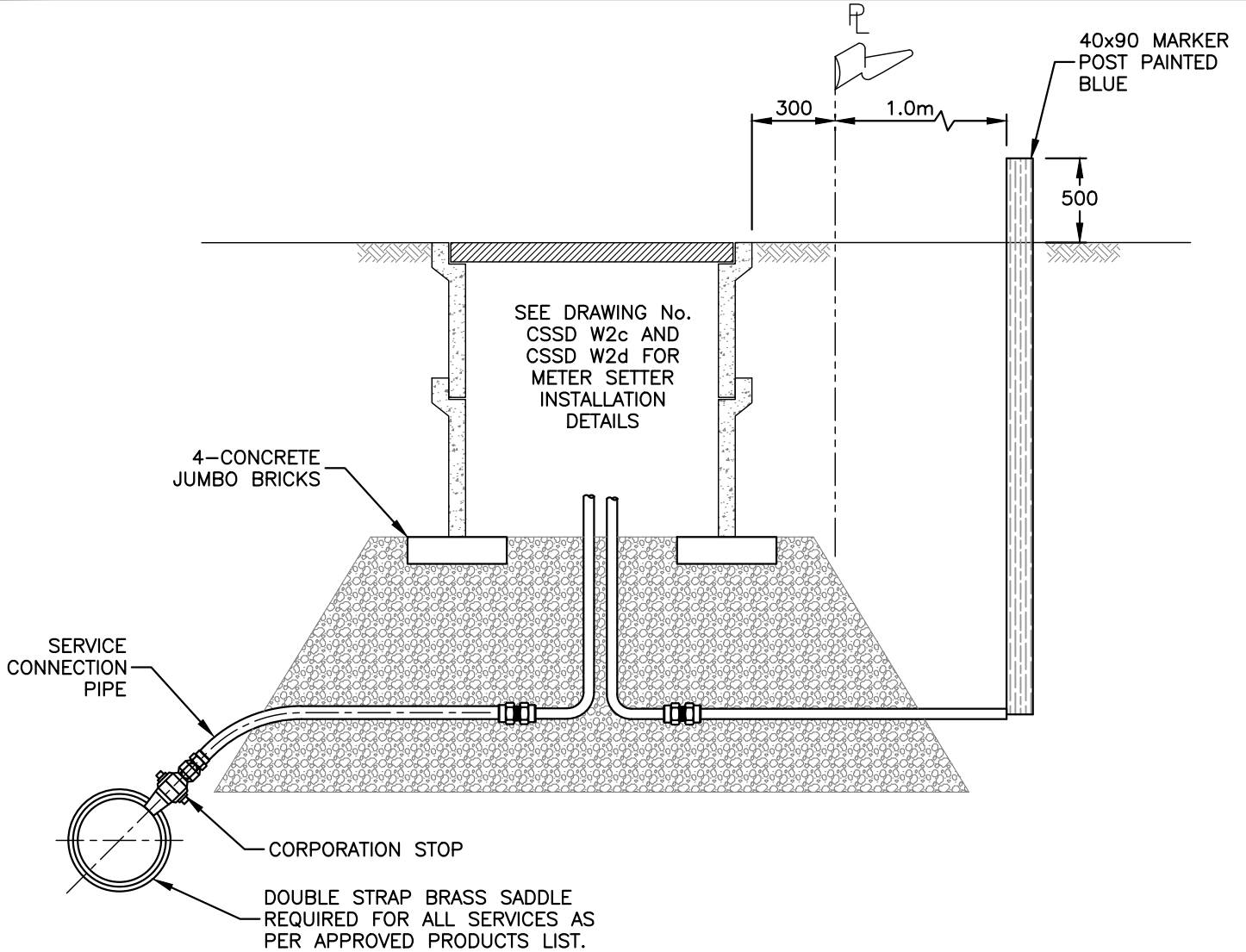

NOTE:

1. THIS DETAIL FOR SERVICES 25 TO 50mm ONLY.
2. PVC SADDLES TO SECTION 33 11 01.
3. INSTALL SERVICE PIPE WITH "GOOSE NECK" IN HORIZONTAL POSITION.
4. REFER TO CONTRACT DRAWINGS, SECTION 33 11 01 FOR DETAILED SPECIFICATIONS.
5. ALL DIMENSIONS ARE IN MILLIMETERS UNLESS OTHERWISE SHOWN.

NOVEMBER, 2017



WATER SERVICE CONNECTION  
 SERVICE BOX

DRAWING NUMBER

CSSD W2a

REVISION NUMBER

0

SCALE

N.T.S.  
 176



**CITY OF COURTENAY  
SUPPLEMENTARY STANDARD DETAIL DRAWING**

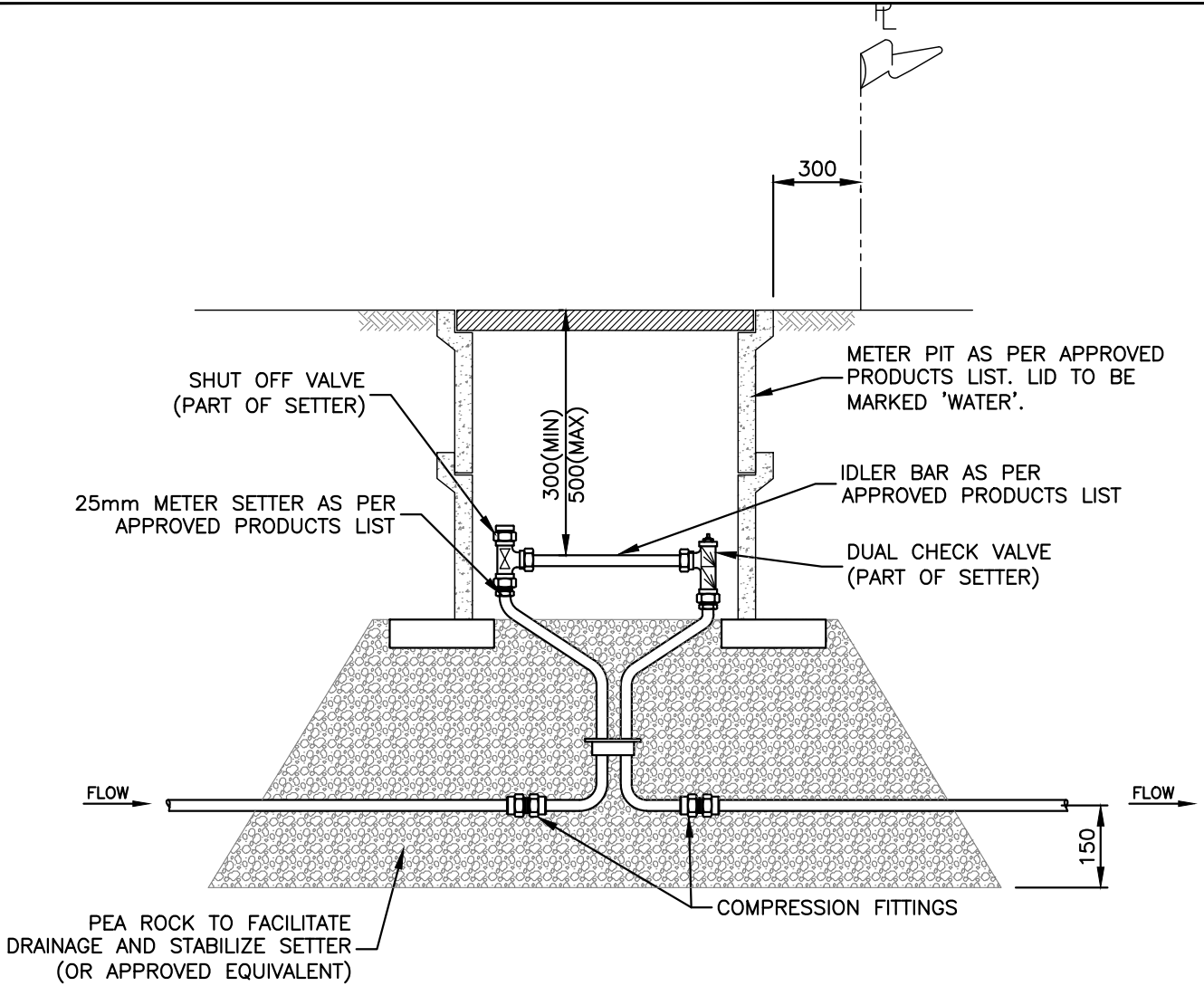

**NOTE:**

1. METER BOX TO BE INSTALLED AS PART OF THE INITIAL SERVICE INSTALLATION.
2. ALL DIMENSIONS IN MILLIMETRES UNLESS OTHERWISE SHOWN.
3. REFER TO CONTRACT DRAWINGS, SECTION 33 11 01 FOR DETAILED SPECIFICATIONS.

NOVEMBER, 2017



**WATER METER SETTER INSTALLATION  
FOR 25mm SERVICE CONNECTION**

DRAWING NUMBER

**CSSD W2c**

REVISION NUMBER

0

SCALE

N.T.S.

177

**CITY OF COURTENAY  
SUPPLEMENTARY STANDARD DETAIL DRAWING**

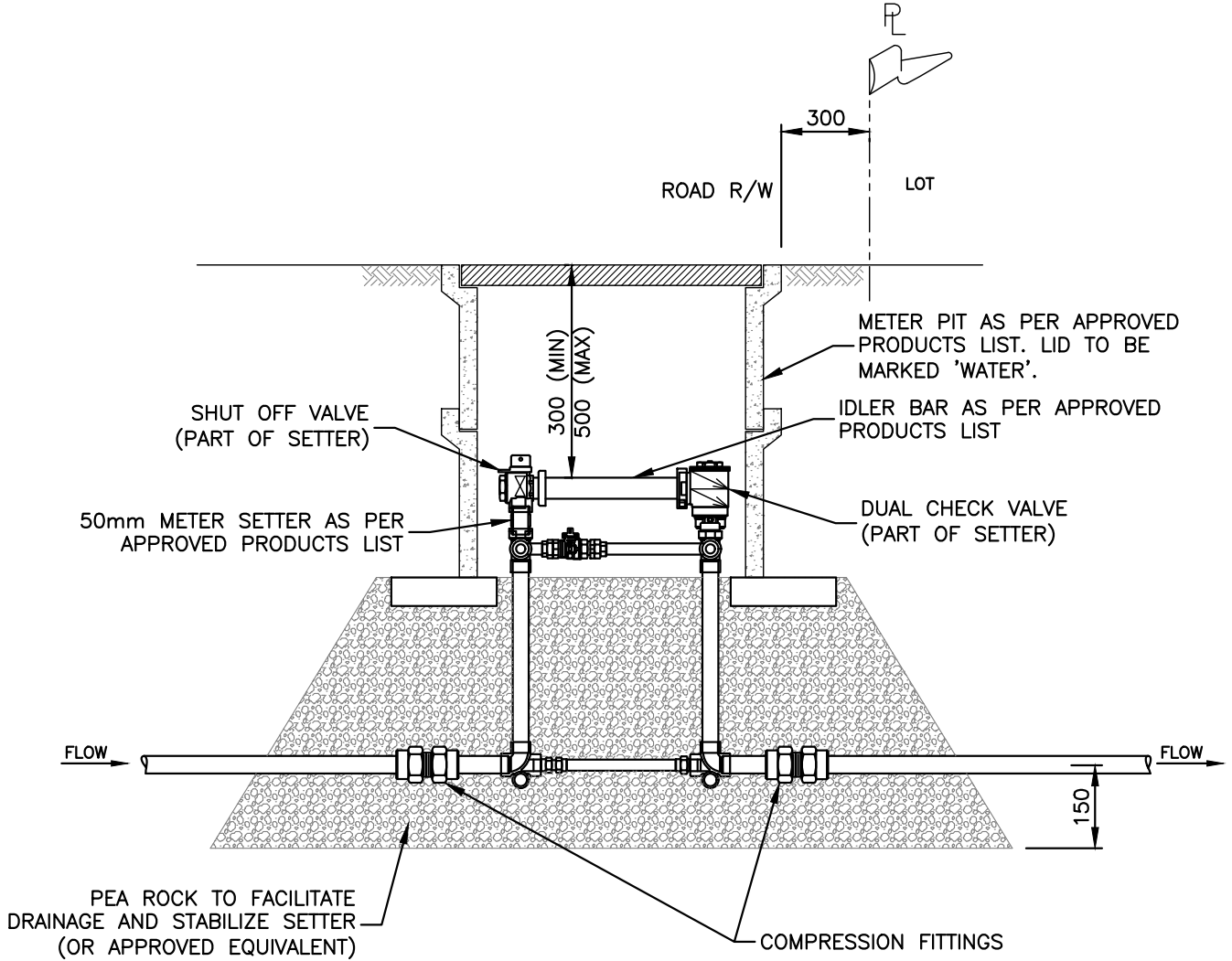

**NOTE:**

1. METER BOX TO BE INSTALLED AS PART OF THE INITIAL SERVICE INSTALLATION.
2. ALL DIMENSIONS IN MILLIMETRES UNLESS OTHERWISE SHOWN.
3. REFER TO CONTRACT DRAWINGS, SECTION 33 11 01 FOR DETAILED SPECIFICATIONS.

NOVEMBER, 2017



**WATER METER SETTER INSTALLATION  
FOR 50mm SERVICE CONNECTION**

DRAWING NUMBER

**CSSD W2d**

REVISION NUMBER

0

SCALE

N.T.S.  
**178**

**CITY OF COURTENAY**  
**SUPPLEMENTARY STANDARD DETAIL DRAWING**

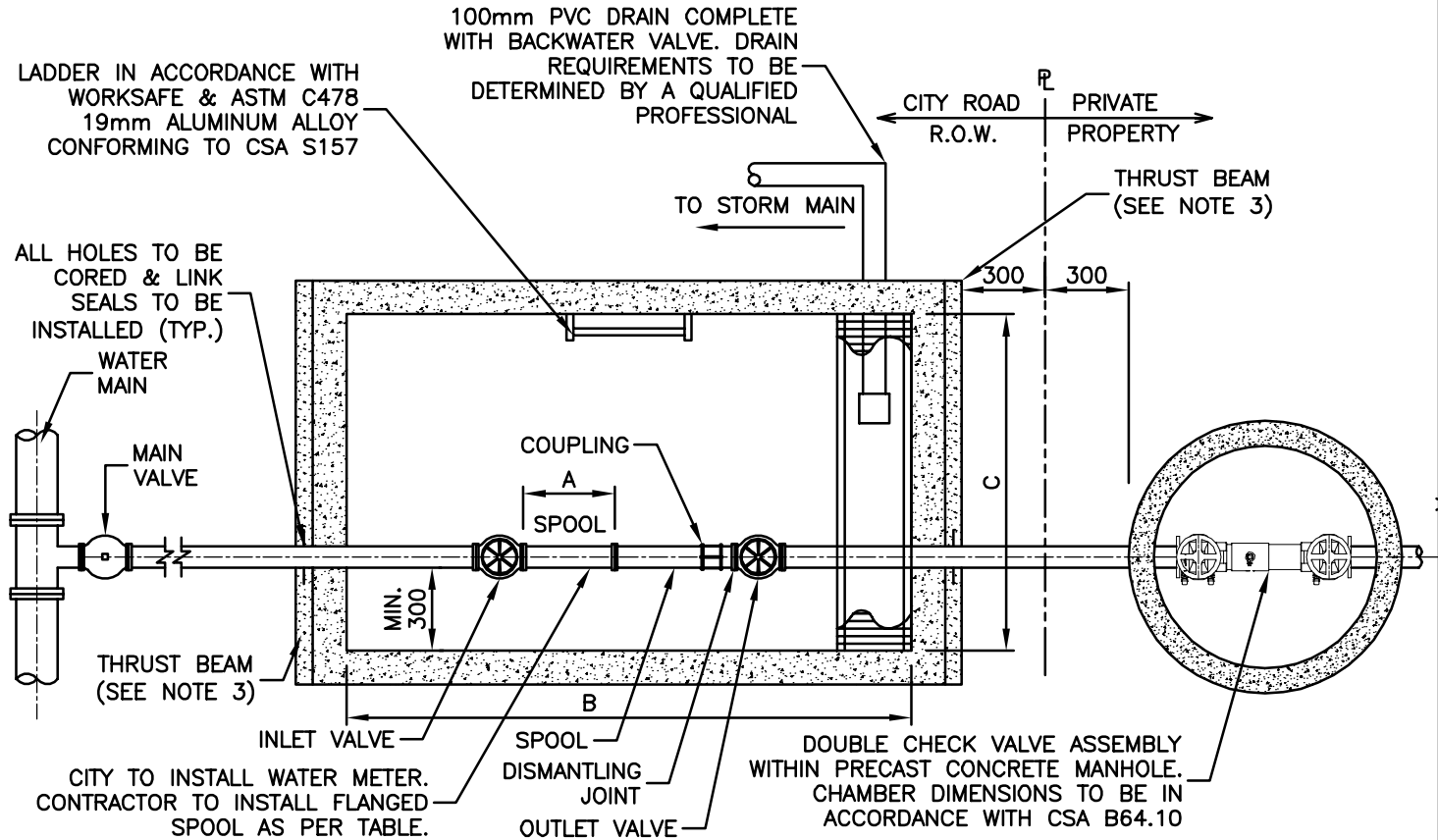

| WATER METER DIMENSIONS SPOOL LENGTH |        |  |        |
|-------------------------------------|--------|--|--------|
| METER SIZE                          | A (mm) | B (mm)                                     | C (mm) |
| 75mm (3")                           | 304.8  | 2060                                       | 1254   |
| 100mm (4")                          | 355.6  | 2060                                       | 1254   |
| 150mm (6")                          | 457.2  | 2060                                       | 1254   |
| 200mm (8")                          | 508.0  | TO BE DESIGNED BY A QUALIFIED PROFESSIONAL |        |
| 250mm (10")                         | 450.0  |  |        |

**NOTES:**

1. THIS DRAWING TO BE REVIEWED IN CONJUNCTION WITH THE CITY OF SUPPLEMENTARY DESIGN GUIDELINES AND SUPPLEMENTARY SPECIFICATIONS.
2. HATCH COVER TO BE DUAL DOOR. H20 OCCASIONAL (STATIC LOADING – NOT FOR DYNAMIC TRAFFIC) LOAD RATED LOCKABLE ALUMINUM LID C/W SPRING ASSISTED HATCH AND LOCK OPEN ARMS. HATCHES TO BE TROUGH FRAME WITH DRAIN DIRECTED TO SUMP.
3. PIPE ANCHORING/RETRAITMENT TO BE DESIGNED BY APPLICANT'S ENGINEER.
4. ALL DIMENSIONS ARE IN MILLIMETRES.
5. METER CHAMBER FLOOR TO SLOPE TOWARD DRAIN.
6. 2121.5 PRE-CAST CONCRETE VAULT TO BE USED UP TO AND INCLUDING 150mm METER SIZE.

NOVEMBER, 2017



**DOMESTIC WATER METER INSTALLATION**  
**FOR GREATER THAN 50mm SERVICE**

DRAWING NUMBER

**CSSD W2e**

REVISION NUMBER

0

SCALE

N.T.S.  
**179**

**CITY OF COURTENAY**  
**SUPPLEMENTARY STANDARD DETAIL DRAWING**

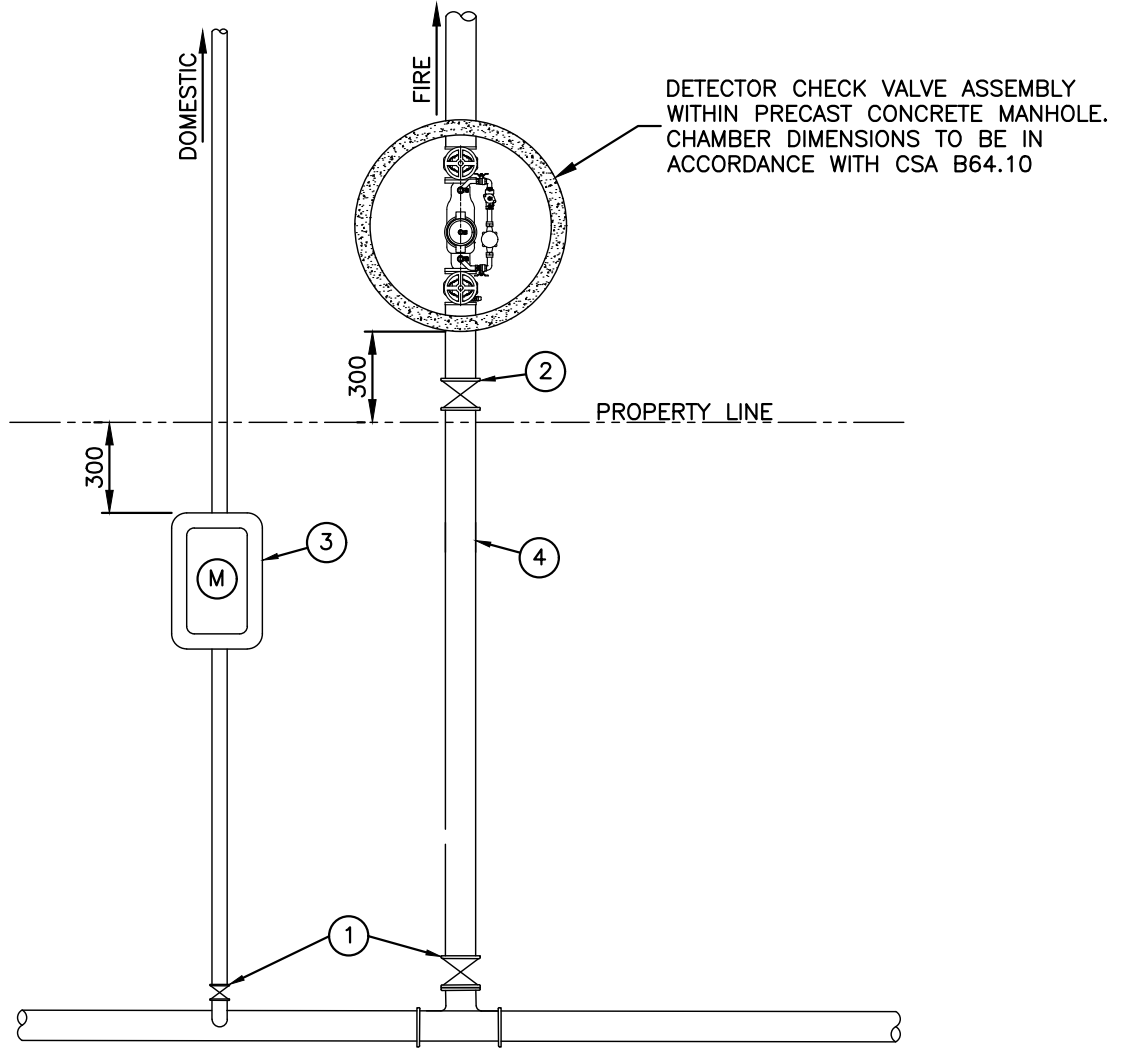

DETECTOR CHECK VALVE ASSEMBLY  
 WITHIN PRECAST CONCRETE MANHOLE.  
 CHAMBER DIMENSIONS TO BE IN  
 ACCORDANCE WITH CSA B64.10

| NO | NAME   |
|----|--|
| 1  | CORPORATION STOP, 25 $\phi$ -50 $\phi$<br>GATE VALVE, OVER 50 $\phi$   |
| 2  | CURB STOP, 25 $\phi$ -50 $\phi$ (IN METER BOX)<br>GATE VALVE, OVER 50 $\phi$   |
| 3  | DOMESTIC SERVICE, 25 $\phi$ -50 $\phi$<br>FOR MORE DETAIL SEE DRAWINGS<br>- CSSD W2a<br>- CSSD W2c<br>- CSSD W2d<br>SERVICES GREATER THAN 50 $\phi$<br>FOR MORE DETAIL SEE DRAWING<br>- CSSD W2e |
| 4  | FIRE LINE SERVICE (SIZE VARIES)  |

NOTE:

1. ALL DIMENSIONS IN MILLIMETRES UNLESS OTHERWISE SHOWN
2. REFER TO CONTRACT DRAWINGS AND SECTION 33 11 01 FOR DETAILED SPECIFICATIONS.
3. INSTALL THRUST BLOCKING AS REQUIRED.
4. SEPARATE DOMESTIC AND FIRE CONNECTION MAY BE PERMITTED IF APPROVED BY THE CITY.

NOVEMBER, 2017



**FIRE / DOMESTIC WATER  
 SERVICE PIPING LAYOUT**

DRAWING NUMBER

**CSSD W2f**

REVISION NUMBER

0

SCALE

N.T.S.

**180**

**CITY OF COURTENAY  
SUPPLEMENTARY STANDARD DETAIL DRAWING**

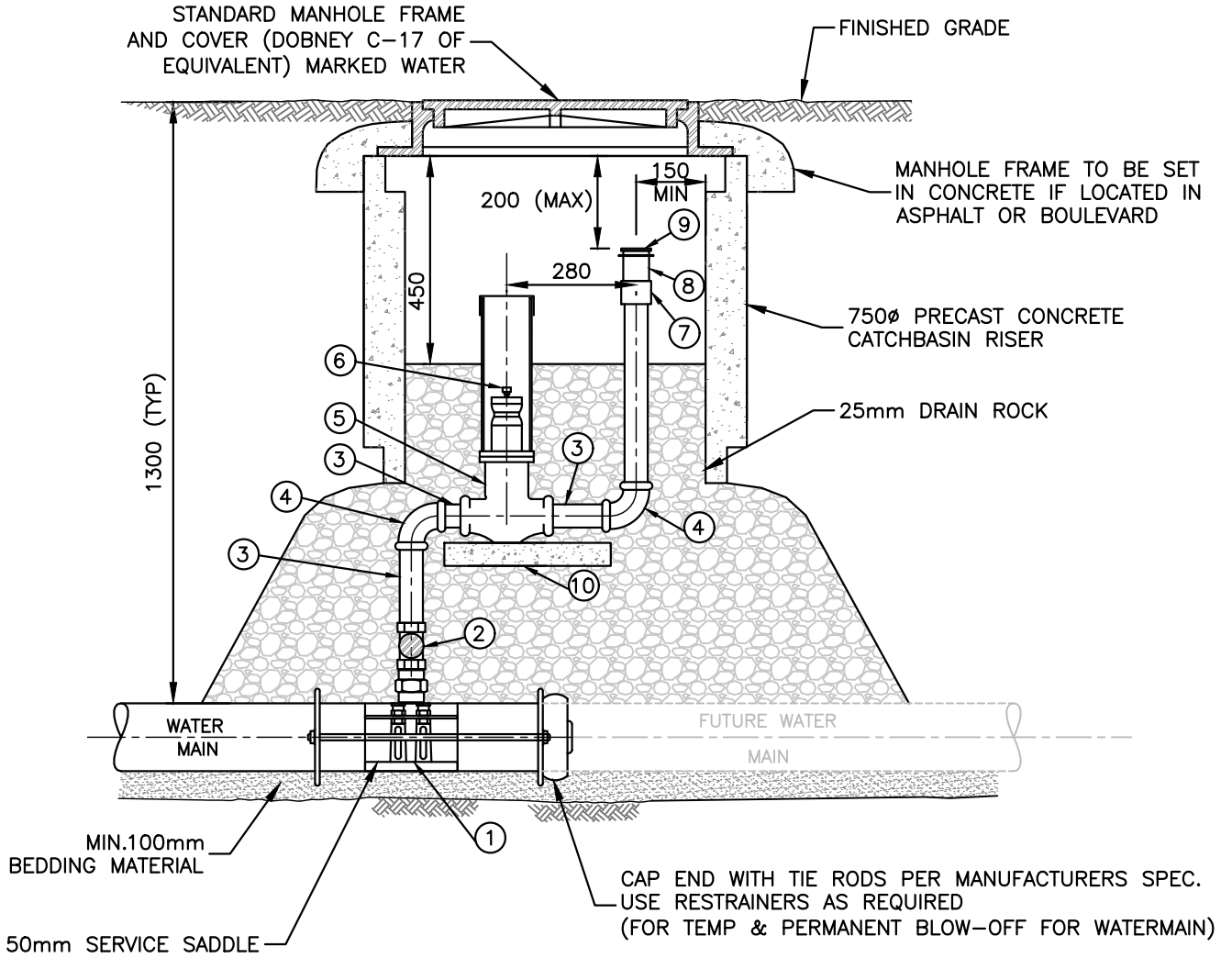

| MATERIALS LIST |  |
|----------------|--|
| ITEM           | DESCRIPTION                              |
| 1              | 50mm SERVICE SADDLE TAPPED AT PIPE CROWN |
| 2              | 50mm GATE VALVE                          |
| 3              | 50mm SS SPOOL PIECE                      |
| 4              | 50mm SS 90° BEND                         |

|    |                                 |
|----|---------------------------------|
| 5  | 50mm CURB STOP WITH DRAIN       |
| 6  | 50mm SQUARE NUT                 |
| 7  | 65mmx50mm BUSHING               |
| 8  | 65mmx65mm ADAPTOR               |
| 9  | 65mm QUICK CONNECT BRASS CAP    |
| 10 | 450x450x50 PRECAST CONCRETE PAD |

**NOTE:**

- FOR INSTALLATIONS SHOWN ON CONTRACT DRAWINGS WHERE WATER TABLE (AT SEASONAL HIGH) IS ABOVE BASE OF DRAIN ROCK, REMOVE 4mm DRAIN HOLE AND AND SUBSTITUTE GRANULAR PIPE BEDDING FOR DRAIN ROCK. (COMPACT PIPE BEDDING TO 95% MODIFIED PROCTOR DENSITY).
- REFER TO MMCD DRAWING W1 FOR THRUST BLOCK DETAILS.
- REFER TO CONTRACT DRAWINGS, SECTION 33 11 01 FOR DETAILED SPECIFICATIONS.

NOVEMBER, 2017



**TEMPORARY AND PERMANENT  
BLOW-OFF FOR WATERMAIN**

DRAWING NUMBER

**CSSD W8**

REVISION NUMBER

0

SCALE

N.T.S.

181

**SCHEDULE 4**  
**STANDARDS FOR SANITARY LIFT STATIONS**



TABLE OF CONTENTS

TABLE OF CONTENTS..... 1

INTRODUCTION..... 1

INTENT OF THE STANDARDS..... 1

SANITARY LIFT STATION DESIGN CRITERIA.....2

1.0 GENERAL SPECIFICATIONS.....2

    1.1 PUMPS..... 2

    1.2 KIOSK ..... 2

    1.3 PIPING/VALVE CHAMBER ..... 3

    1.4 VENTILATION..... 4

    1.5 LIFT STATION TANK..... 4

    1.6 EQUIPMENT ..... 4

    1.7 EMERGENCY BACKUP GENERATOR..... 5

    1.8 WARRANTY..... 6

    1.9 WATER CONNECTION..... 6

    1.10 SITE FENCING ..... 6

2.0 LIFT STATION ELECTRICAL DESIGN STANDARDS ..... 6

    2.1 STANDARD LIFT STATION ELECTRICAL SPECIFICATION..... 6

    2.2 USER INTERFACE ..... 7

    2.3 VFD STATION SUPPLEMENTARY SPECIFICATION ..... 8

    2.4 ENTRY AND ALARM TEST MODE..... 8

3.0 CITY SCADA SYSTEM.....9

4.0 COMMUNICATIONS BETWEEN SCADA AND LIFT STATION ..... 10

    1.0 GENERAL..... 11

    2.0 PRODUCTS ..... 12

    3.0 EXECUTION ..... 18



## INTRODUCTION

The use of sanitary lift stations is generally discouraged and the City must approve any proposal for a lift station prior to submission of any engineered drawings for a lift station. Lift stations are considered a "special case" and are to be designed by a qualified professional. The following will form the general design requirements for duplex lift stations categorized as small to mid-sized lift stations. For stations larger than 50 l/s, or that require more than two pumps, authorization must be obtained from the City on a case by case basis, and the following standards may not fully apply.

Unless documentation provided by the City of Courtenay along with a specific request for tender or request for proposal states specifically that a provision set forth has been waived, all provisions are to be satisfied.

The requirements set forth in these standards are minimum requirements that shall be applied universally by all parties performing services for and/or providing equipment to the City of Courtenay. This includes, but is not limited to, all component parts that may form part of package systems.

This document is part of a series of standards and as such should not be viewed in isolation of all other City of Courtenay associated standards which may modify and/or clarify the requirements set forth within this document.

The City of Courtenay may, on a case-by-case basis, and at the City's sole discretion, approve deviations from these standards.

## INTENT OF THE STANDARDS

The Design Criteria are intended to provide direction to the Applicant and their Engineer on the elements required to be considered in the design of sanitary lift stations. It is intended to be used in conjunction with the MMCD Design Guideline Manual and the City of Courtenay Subdivision and Development Servicing Bylaw Schedule 1.

The Supplementary Specifications are intended to provide direction to the Applicant and their Engineer on the specifications that must be incorporated into building servicing contracts for the installation of new sanitary lift stations. The Supplementary Specifications are to be used in conjunction with the City of Courtenay Subdivision and Development Services Bylaw Schedule 2 and Schedule 3 and the Master Municipal Construction Document (MMCD).





## SANITARY LIFT STATION DESIGN CRITERIA

### 1.0 GENERAL SPECIFICATIONS

#### 1.1 Pumps

- (a) All sanitary lift stations shall be designed with a minimum of two pumps, each capable of handling the Peak Wet Weather Flows independent of the other. The pump that is furthest away from the inlet shall be supplied with a 4901 flush valve.
- (b) Each pump must be:
- capable of passing solids up to 75 mm in size;
  - equipped with hour meters;
  - easily removed for maintenance;
  - constructed to operate on a voltage based on HP rating as shown on the table below:

| Pump Size         | Approved Voltages                    |
|-------------------|--------------------------------------|
| Less than 5HP     | Single phase 240V / Three phase 208V |
| 5HP – 10HP        | Three phase 208V / Three phase 600V  |
| Larger than 10 HP | Three phase 600V                     |

- (c) Motor cables, power cables, etc. shall be continuous from the lift station to the kiosk. Cables are not to be spliced. Only one power cable is allowed in one conduit.

#### 1.2 Kiosk

All auxiliary equipment and control panels shall be mounted in a secure lockable kiosk adjacent to the station. The kiosk shall be located not less than 1.2 metres and not more than 3 metres from the station lid, with the controls section of the kiosk facing the wet well and facing north (where practical to do so.). The kiosk shall be founded on a concrete foundation, and should be made from powder coated aluminum, with a standard green finish. All kiosks shall be supplied with a rubber gasket between the aluminum kiosk and the concrete to prevent water leakage into the kiosk.

The electrical Kiosk shall be CSA Type 3R rated and fabricated from marine grade aluminum in accordance with the following Ministry of Transportation and Infrastructure Kiosk Specifications:

- General Material Requirements: 402.3.1
- Connecting Hardware 402.3.2
- Fabrication Mechanical Requirements, General Requirements 402.4.1
- Welding 402.4.2
- Door Gaskets 402.4.4
- Kiosk Environmental Requirements, General 402.4.8.1
- Kiosk Fan and Heater Thermostat 402.4.8.5
- Kiosk Finish 402.6
- Electrical Kiosk shall be powder coated "Fence Post Green".



- Plan Pouch 402.9

The kiosk shall be fabricated with sufficient bracing to form a structure capable of withstanding transportation, wind, snow and ice loading. The kiosk manufacturer is responsible for obtaining structural and seismic certification from a professional engineer registered with Engineers and Geoscientists BC. Structural certification shall include recommendations for fastening methods.

The kiosk shall contain separate compartments for:

- pump control;
- service entrance and distribution; and
- fan and duct section, complete with isolated cable junction chamber vented to the atmosphere.

The kiosk shall be designed to contain:

- all control and telemetry equipment within the pump control compartment;
- an electrical service entrance that is complete with required appurtenances and components shall be arranged in a manner acceptable to B.C. Hydro;
- all power distribution equipment in the service entrance and distribution section, with exception to a 120/240 or 120/208V electrical panel which shall be mounted within the pump control compartment;
- an extra 120 volt receptacle within the pump control and service entrance/distribution sections;
- an automatic transfer switch in the service entrance and distribution section;
- a manual transfer switch in the service entrance and distribution section;
- a receptacle for mobile backup generator on the exterior of the kiosk;
- intrusion and fault alarm keypad and panel, keypad to be accessible, with equipment mounted within the pump control compartment;
- exterior lighting mounted to an overhead pole capable of illuminating the area around the tank lid to WorksafeBC required standards;
- a heater within each of the pump control and service entrance/distribution sections; and
- a digital clock.

The fan and duct section shall be isolated from the pump control and service entrance/distribution sections by means of a continuous weld.

### 1.3 Piping/Valve Chamber

All piping within the wet well shall be stainless steel or approved equivalent, and all stations shall feature an external separate valve chamber for valves and flow measurement equipment. The valve chamber can be either fiberglass or pre-cast concrete with suitable lockable lids with lift assist mechanisms as required.

Each pump discharge shall have a ball check valve or lever type swing check valve.



Each pump discharge shall have a plug valve installed downstream of the check valves.

Drain to be provided at floor elevation and floor to be sloped to convey inflow of water or sewage toward drain inlet. The drain shall include a backwater valve and p-trap to prevent sewage and gas from entering the piping/valve chamber.

#### 1.4 Ventilation

Ventilation at each station is to be by forced air using a fixed speed fan that runs continuously. The minimum ventilation rate is to be 12 air changes per hour or higher if required for safety considerations. The fan shall be located in the kiosk and be sealed to the inlet blower line. The blower shall indicate failure on the control panel.

Each station shall have a minimum of one vent stack, and shall have odour control installed. As a minimum, the vent stack shall be equipped with an activated carbon filter capable of conveying the required air flow rate without excessive pressure loss: Calgon SweetVent or equal.

#### 1.5 Lift Station Tank

The lift station tank to be of fiberglass construction.

Wet wells shall be designed with the following features:

- Include a benched bottom to direct all solids into the pump suction;
- Include surface access with a lockable, waterproof fiberglass or aluminum cover. Access hatches must include hydraulic assist and safe hatch;
- Provide access that is 200 mm to 500 mm above the finished grade to prevent vehicles from riding overtop of the structure;
- Contain aluminum (or fiberglass) ladder mounted so it does not interfere with the removal and installation of the pumps, etc. The ladder shall be designed to extend and lock least 1.0 metre above the tank access. Ladders mounts to be structurally sufficient to prevent puncturing of the tank wall, where mechanical fasteners are to be used, the wall shall be reinforced to provide sufficient capacity for the type and size of fastener. Integrated fiberglass ladders shall be fixed mounted to the fiberglass wall with appropriate reinforcing of the fiberglass as specified by the manufacturer;
- Contain a platform above the high water level float to permit wet well access wherever the total depth from ground level to wet well floor exceeds 2.4 metres;
- Include 1 base and davit complete with hand operated winch capable of lifting the pumps clear of the lift station (as per the City's Approved Products List);
- Include 1 base and davit for confined space entry. (as per the City's Approved Products List);
- Contain explosion proof lighting capable of illuminating the interior of the tank.

#### 1.6 Equipment

All equipment must be CSA Approved and Work Safe BC compliant.



## 1.7 Emergency Backup Generator

All sewage lift stations shall be equipped with an emergency backup generator unless otherwise approved by the City. The generator transfer switch shall be of the automatic type. The generator shall be diesel fueled unless otherwise approved by the City. Diesel fuel tanks shall be base tanks integrated into generator unit by OEM, shall include double wall containment, and shall be sized to run the generator for at least 24 hrs continuously at 100% load. The concrete base to install the generator shall be provided with a spill containment structure to capture any spillage. The generator shall have a 1.2m clearance all around, and it shall be provided with a noise control package. Noise Control Package Specification for Generator shall be residential rated. Sound attenuation includes enclosure and exhaust muffler package. Sound attenuation system performance shall result in measured sound levels not to exceed 65 dB @ 10.7 metres. Design Engineer shall perform a load analysis with the sequence of motor starting in order to know the motor starting loads and the motor running loads. Such electric load calculations must be done in kVA units to account additional loads due to low power factor. The generator shall have a motor starting kVA capacity to limit the voltage dip to no more than 15% for any motor starting conditions. Such generator load analysis must be included in the engineering report. The generator manufacturer must be pre-approved by the City prior to design of the backup system.

The generator shall also come equipped with a permanently-mounted resistive load bank, with a full load that equals +/- 80% of the generator unit's full load capacity. The load bank shall also include the following specifications:

- Duty Cycle: Rated for continuous operation.
- Load Steps: 5, 10, 10, 25, 50, 100 KW
- Cooling System: integral with generator cooling system
- Sound dampening: integral with generator muffling system
- Operator Controls: Control Panel housed in a NEMA-type wall mount enclosure including:
  - Main Power ON/OFF Switch, Power ON Indicator, and Master Load ON/OFF Switch.
  - Load selection shall be provided by individual industrial lever-type toggle switches for on/off application of resistive load segments, one provided for each load step.
  - Auto Load Dump Circuit: A remote load dump circuit is provided as part of the load bank control circuit.
- Provisions shall be provided to trip the load bank off-line from a normally closed set of auxiliary contacts from an automatic transfer switch or other device. In the event of a utility failure, all load is removed.

**Automatic Load Controller:** Automatic Load step controller that maintains a minimum load on the generator set. The controller shall monitor the connected downstream loads and will automatically add or subtract load steps in response to overall load changes as to maintain a minimum load level on the generator set.



### 1.8 Warranty

All lift station components shall be warranted in accordance with the manufacturer’s warranty, and such warranty shall be explicitly stated in a warranty statement (section) provided with the Operations and Maintenance Manuals submitted upon acceptance of the Lift Station by the City.

### 1.9 Water Connection

A 50 mm water service connection for cleaning purposes must be provided at the site. The service must include a dry standpipe and appropriate cross-connection control devices located in an above ground heated lockable cabinet. The connection shall also include an on/off ball valve and a 38mm quick connect cam-lock fitting. Cross-connection control devices must be designed to be compliant with CSA standard B64.10-11 (Selection and Installation of Backflow Preventers/Maintenance and Field Testing of Backflow Preventers). RP backflow device shall be located in an above ground kiosk.

### 1.10 Site Fencing

1.8m black epoxy coated perimeter fencing is to be provided.

## 2.0 LIFT STATION ELECTRICAL DESIGN STANDARDS

### 2.1 Standard Lift Station Electrical Specification

All lift stations shall include at a minimum the following features and capabilities:

|                         |  |
|-------------------------|--|
| Manual pump controls    | It shall be possible to set each pump into manual (Hand) mode. When in the manual mode the control of the pump shall be independent of (and unaffected by) the actions (or absence) of the controller or fail-safe pump control relays.  |
| Motor type and starting | All pumps 10hp or larger require soft starting devices or are to be speed controlled via Variable Frequency Drives.  |
| Controller              | The station controller shall conform to the City of Courtenay Approved Products List.  |
| Float Switches          | Each station shall be supplied with a high level and low level float switch. These shall be either an ITT Flygt float level tree type (mercury) or an acceptable alternative as Approved by the City and CSA certified. Guides must be used for all float levels. The low level float is to be set at a level just above the pump intake. The high level float is to be set at a level no higher than the obvert of the lowest inlet pipe. |



|   |  |
|---|--|
| Fail Safe Operation                                 | The high level float shall trigger operation of pumps, the operation of which shall be independent of the main station controller. The pump operation shall be wired to cease on either activation of the low level float or time-out of a timer relay. During normal operation the high level float will not be activated.  |
| Level monitoring                                    | Wet well levels shall be monitored using an ultrasonic sensor or pressure transducer connected as an analog input to the control unit. This level is to be used for pump control and shall be reported to the central monitoring station.  |
| Programmable operation                              | Pump start and stop levels are to be programmable and set through the local pump controller HMI and via SCADA.   |
| Pump supervision                                    | Pumps shall be monitored, as a minimum, for stator over temperature faults, seal leakage and over current condition.   |
| Flow rate   | Flow rate data is to be reported by flow monitoring device.  |
| Intrusion alarm for kiosk or building               | Access to the electrical controls is to be monitored by a contact switch, and an alarm condition shall be generated when the contact is broken.  |
| Receptacle for plug in of standby generator         | Each station, including those which include local generator, shall be equipped with a receptacle for plug-in of City standby generator, mounted on the exterior of the building or kiosk within a lockable NEMA-4X enclosure (padlock provided by the City).   |
| Alarms  | The following alarms shall be generated and reported by the alarm system by way of a dedicated telephone connection. The alarms shall also be connected to the lift station controller to allow for annunciation through the City's SCADA system <ul style="list-style-type: none"> <li>• Intrusion Alarm</li> <li>• Loss of Power</li> <li>• High level alarm</li> <li>• Low level alarm</li> <li>• Pump monitoring alarms (leakage, high temperature)</li> <li>• Generator Faults (if generator installed)</li> <li>• Breaker tripped</li> <li>• Float switch failure</li> </ul> |
| UPS backup for controller and communications system | A UPS standby power system is required. The UPS must provide power to the controller for at least one hour in the event of a power outage.   |

## 2.2 User Interface

The user interface in a typical lift system consists of manual controls for emergency and maintenance purposes, and an electronic interface directly to the controller.



Manual Controls

The operator interface at this level shall be kept to a minimum. Auto/Off/Manual selectors for each pump are to be provided. These controls shall function independently of the controller. When in placed in manual mode the appropriate pump shall start. When placed in the Off condition the pump shall not start regardless of input from the controller. In Auto mode the pump is controlled by the controller. Pump run time meters shall be installed for each pump.

Status lamps are required as follows:

- One lamp indicating kiosk power
- One status lamp for each pump indicating pump run condition
- One status lamp for each pump indicating a failure condition

Controller Interface

Each station shall also include a station control Human-Machine-Interface (HMI), mounted in the door of the control cabinet. This control keypad is used to view and reset alarm status, and to configure the operation of the station. The HMI shall conform to the City of Courtenay Approved Products List, and shall integrate directly with the station controller.

2.3 VFD Station Supplementary Specification

All lift stations involving VFDs shall include the features and capabilities outlined above plus the following features and capabilities:

|                           |   |
|---------------------------|---|
| VFD                       | A solid state variable frequency drive, sized for the motors associated with the project, with inline load filters. Xylem ACS550 or similar.            |
| VFD Manual Mode           | The VFD shall be programmed to run the pump at an appropriate default speed in manual mode (when started).  |
| VFD controller connection | Connection to the VFD is by analog output from the controller.  |
| VFD output monitoring     | The controller shall monitor and make use of the speed output, and current outputs of each VFD. These shall be made available to the monitoring system. |

2.4 Entry and Alarm Test Mode

Each pumping station panel will have a key lock access to the control cabinet. A momentary spring-to-centre rotary selector switch shall be provided to switch to select between Test & Normal mode of operation. In Test mode the system shall behave as follows:

When momentarily switched to the "Test" position all normal alarms from the station will be acknowledged and disabled for 30 minutes, and a local "Test Mode" pilot light will illuminate.



In addition, a test alarm shall be triggered which will be treated as a low priority alarm at the SCADA system.

The station controller begins a phased monitoring of the situation, as described in the following table.

| Phase | Description   |   |
|-------|---|---|
| 1     | The input is activated by the test mode selector switch.<br>Result: Work time begins (25 minutes).  |   |
| 2     | The input has been activated longer than the Work time.<br>Result: Common alarm outputs are activated. Warning time begins. (5 minutes)   |   |
| 3     | Personnel acknowledge their presence within the Warning time.<br>Result:<br>Work time is restarted.<br>Common alarm outputs are set to passive.   | No acknowledge is received within the Warning time.<br>Result:<br>Personnel alarm is generated. |
| 4     | The selector switch is momentarily placed in the "Normal" position, or the kiosk/station door is closed.<br>Result:<br>"Test Mode" pilot light extinguishes and station alarming returns to normal. |   |

### 3.0 CITY SCADA SYSTEM

City of Courtenay sewage pumping stations are to be compatible with a central monitoring system, planned for some future date. This section is provided to explain the requirements on all new lift stations in order to ensure compatibility with the planned SCADA system.

Key features of the planned SCADA system are planned to include:

- real time information regarding the status of stations throughout the municipality in order to efficiently respond to faults and other issues as they arise;
- limited remote control capability of the stations, which in certain cases may avoid the need for a site visit;
- historical information and other data that will assist with proactive maintenance activities; and
- historical information and other data that can be used to make informed decisions guiding future infrastructure development.





#### 4.0 COMMUNICATIONS BETWEEN SCADA AND LIFT STATION

Stations constructed pre SCADA system shall support the future installation of communications equipment. Sufficient space is to be provided in the kiosk for a lockable louvred/ventilated box that will contain transmitter/receiver and networking equipment. In addition, a 100mm underground communications conduit shall be stubbed out from the kiosk/building foundation to allow for a future installation of antenna.



CONSTRUCTION SUPPLEMENTARY SPECIFICATIONS

- |     |                              |    |  |
|-----|------------------------------|----|--|
| 1.0 | GENERAL                      | .1 | This section refers to those portions of the Work that are unique to the supply and installation of prefabricated submersible sewage lift stations. This section must be referenced to and interpreted simultaneously with all other sections pertinent to the works described herein.   |
| 1.1 | Related Work                 | .1 | Electrical <span style="float: right;">Division 26</span>  |
|     |                              | .2 | Concrete Reinforcement <span style="float: right;">Section 03 20 01</span>   |
|     |                              | .3 | Cast-in-Place Concrete <span style="float: right;">Section 03 30 53</span>   |
|     |                              | .4 | Aggregates and Granular Materials <span style="float: right;">Section 31 05 17</span>  |
|     |                              | .5 | Excavating, Trenching, and Backfilling <span style="float: right;">Section 31 23 01</span>   |
|     |                              | .6 | Sanitary Sewers <span style="float: right;">Section 33 30 01</span>  |
|     |                              | .7 | Sewage Force mains <span style="float: right;">Section 33 34 01</span>   |
| 1.2 | Shop Drawing and Data Sheets | .1 | Before fabrication, the supplier shall submit shop drawings to the City for review. The submission shall include data sheets for all equipment to be ordered, along with a full drawing package for the electrical kiosk (external kiosk, internal layouts, wiring and controls diagrams)  |
|     |                              | .2 | Lift station structural drawings, stamped by a Professional Engineer registered in British Columbia, shall be provided for the fibreglass wet well, the reinforced concrete base, the electrical kiosk enclosure and the anchoring systems for the generator, electrical kiosk and wet well.   |
| 1.3 | Requests for Approved Equals | .1 | Any requests for approved equal shall contain sufficient documentation regarding the service organization which is available to back up the tendered pumping units. In particular, the service organization shall: <ul style="list-style-type: none"> <li>• have been in existence a sufficient length of time to have established a reputation which can be backed up with references;</li> <li>• have a number of qualified employees whose major commitment is to carry out service calls; and</li> <li>• have a well-equipped local maintenance shop.</li> </ul> |
|     |                              | .2 | The Contractor shall also be prepared to demonstrate the availability of commonly required spare parts. If these are not kept in stock locally, the anticipated delivery period must be clearly indicated in the Form of Tender.   |



- 1.4 Commissioning Plan .1 A commissioning plan should be provided to the City for review 2 weeks in advance of the scheduled commissioning.
- 2.0 PRODUCTS
- 2.1 Structure .1 Chamber:
- .1 The main chamber shall contain the pumps and associated equipment and shall be a vertical cylinder.
  - .2 The shell shall be constructed of Fibreglass Reinforced Plastic (FRP) and shall provide sufficient rigidity to resist deflection during installation and to resist pump loads and vibrations.
  - .3 The main chamber shall be reinforced with external reinforcing rings.
  - .4 Four (4) lifting "eyes" adequate for the entire weight of the completed station, including all installed equipment, shall be provided.
  - .5 Where inflow, discharge and ventilation lines, pass through the tank wall, the wall shall be reinforced.
  - .6 The connecting flanges shall be ANSI B-16.1, Class 125, unless shown otherwise on drawings.
  - .7 Color of the fibreglass interior shall be sanitary white. The exterior shall be dark green.
  - .8 Hold down lugs, complete with hold down bolts, shall be provided with sufficient strength to anchor the lift station to the reinforced concrete base, preventing flotation.
  - .9 The wet well shall be smooth and free of projections and pockets which could impede flow and collect sediment.
  - .10 An aluminum access ladder shall be provided as per Work Safe BC requirements. After installation of the complete lift station, all equipment shall be capable of servicing from the upper chamber.
  - .11 Electrical connection points shall be provided for the pump motors, light, and float conduits.



.2 Physical Properties of FRP Fabrication:

.1 The material of all tanks shipped shall meet the following minimum requirements:

| <u>Property at 73° F.</u> | <u>ASTM Test</u> | <u>Value</u>              |
|---------------------------|------------------|---------------------------|
| Tensile Strength          | D638             | 8,000 - 16,000 psi        |
| Compressive Strength      | D695             | 14,000 - 27,000 psi       |
| Flexural Strength         | D790             | 16,000 - 30,000 psi       |
| Flexural Modulus          | D790             | 1.0 x 10 <sup>6</sup> psi |
| Hardness (average)        | D790             | Barcol 40                 |

.2 Fiberglass tank to be helically filament wound utilizing chemically inert ISO resins. The laminate shall contain at least 60% and not over 70% glass by weight. All FRP work shall meet or exceed the following standards:

|          |                   |
|----------|-------------------|
| C.G.S.B. | 41-GP-22          |
| A.S.T.M. | 3299 and 2563-2.4 |
| A.S.T.M. | D883-69           |

.3 The maximum load rating permitted on the top of the tank must be posted on a plaque on the inside of the lid. The plaque must clearly visible when the lid is open.

.3 Construction

.1 Laminates shall be dense, without voids, dry spots, foreign inclusions, air bubbles, pinholes, or delamination and shall not be cracked or crazed. Such deficiencies shall be removed by grinding and replaced with hand laid matt and roving exceeding the amount removed. The fabricated unit shall have a smooth white inner surface and shall have a dimensional tolerance of plus or minus 6mm from design dimensions.

.2 Bonded joints shall be made by wrapping with strips of fibreglass mat soaked in resin. The wrap material shall be at least as thick as the heaviest plastic section joined, and it shall extend to either side of the joint a sufficient distance to make the joint at least as strong as the pieces joined. Interior joints shall be coloured white to match the interior surfaces; exterior joints shall be of the same colour as the exterior surface.



- .3 The inside surfaces of bonded joints shall be sealed with one layer of mat and then coated with resin to a minimum of 2.5mm thick.
- .4 All exposed interior and exterior surfaces shall have sufficient resin coating 0.51mm minimum thickness, to avoid exposure of glass fibres.
- .5 To prevent "flowing" of the final resin coat, it shall be bonded by using "Veil" glass fibre.
- .6 All cut edges and drilled holes shall be coated with resin so that no glass fibres are exposed and voids filled.
- .7 Structural elements having edges exposed shall be reinforced with chopped strand glass mat.
- .8 The minimum tank wall thickness shall be 16mm and shall be externally reinforced to resist soil, bearing, hydraulic, and handling loads, both internal and external. Wall thickness to be increased as required to resist loading.
- .9 The resin used shall be a commercial grade and shall be evaluated by test of previous service to be acceptable for use in domestic sewage applications and suitable for installation underground throughout Canada.
- .10 Ultraviolet light inhibitors to be used on all external surface in accordance with resin manufacturer's instructions.

2.2 Submersible Sewage Pumps

.1

Pumps to be equipped with ANSI discharge flange. Pumps shall be a centrifugal, submersible, non-clog, bottom suction, capable of passing a 76mm solid. Pumps and motors shall incorporate the following:

Impeller: Cast iron.

Volute/Motor Frame: Cast iron, close coupled to seal chamber. Volute to be equipped with quick discharge nozzle to provide an automatic rapid and leakproof gravity lock type connection or disconnection from the fixed elbow. Sliding guide brackets to slide along guide rails.

Shaft: Stainless Steel.

Seals: Double mechanical seals (tungsten carbide to carbide upper and tungsten carbide to tungsten carbide lower).



Bearings: Anti-friction suitable for a minimum bearing life of 50,000 hours B10 life under operating conditions.

Fluid Operating Temp.: 0°C to 20°C.

Fluid Specific Gravity: 1.0

Fluid Type: Domestic Sewage

Fasteners: Stainless Steel (ASTM TYPE 316).

- .2 Motors shall be CSA approved submersible squirrel cage induction type with Class F insulation and non-hydroscopic windings. Service factor shall be 1.0. Use EEMAC Design B. If higher starting torque is required for the equipment loading, use EEMAC Design C.

Pump motors shall come equipped with means of communicating seal leaks and over-temperature conditions.

- .3 Power cables shall be factory-sealed into the motors and flush valve. They shall be of a type of construction acceptable to the electrical inspector. Cables shall be of sufficient length to reach the Control Kiosk without splices.

Power cables shall be equipped with a disconnect switch located inside the wet well, complete with lockout. Disconnect switches to be Meltric Decontactors or approved equal.

- .4 The pump motor nameplates shall be mounted in the Kiosk or Panel.

- .5 Pumps shall be painted with epoxy and equipped with sacrificial zinc anodes to provide corrosion protection.

- .6 Pump P2 to be equipped with Flygt Model 4901 Mix Flush Valve or approved equal.

- .7 Contractor shall supply the following spare equipment:

- one (1) impeller
- one (1) spare pump

2.3 Fixed Discharge Connection

- .1 Fixed discharge elbow, quick disconnect type, with steel soleplate, lower guide rail holder and drilled for anchor bolts.



|      |                             |    |   |
|------|-----------------------------|----|---|
| 2.4  | Lifting Chains              | .1 | Lifting chains to be Grade 80 Accoloy A8 material, rated with a working load of 1900 kg and shall be NAR approved for overhead lifting, finish to be galvanized. Chain length to be sufficient to connect between pump and chain hoist. |
| 2.5  | Guide Rail Assembly         | .1 | Schedule 40 galvanized steel pipe c/w upper guide bar holder.   |
|      |                             | .2 | All fittings and connectors to be galvanized.   |
| 2.6  | Ventilation Duct Work & Fan | .1 | Inlet duct shall be provided for air blown into the lift station and a vent shall release exhaust air.  |
| 2.7  | Lighting Fixture            | .1 | The wet well light shall be an explosion-proof, wall-mounted, LED fixture suitable for Class 1 locations, complete with globe and guard, RAB Type EB 123 or equal. Switch by General Contractor.  |
| 2.8  | External Piping             | .1 | As per the Contract Drawings.   |
| 2.9  | Internal Piping             | .1 | Sewage piping shall be stainless steel.   |
| 2.10 | Plug Valves                 | .1 | Plug Valve, c/w lever. Flanges to ANSI B-16.1, Class 125.   |
| 2.11 | Check Valves                | .1 | Ball check valve. Flanges to ANSI B-16.1, Class 125.  |
| 2.12 | Level Regulators            | .1 | Provide five ENM-10 Flygt level regulators to stop both pumps, start lead pump, start standby pump, high level alarm, low level alarm for 24 volt operation, each with sufficient cable suitable for the installation.                  |
|      |                             | .2 | Provide one aluminum liquid level hanger, with wall bracket mount and flat switch conductor hooks for excess cable. Hanger shall also provide threaded strain-relief squeeze connectors for each level regulator.                       |
| 2.13 | Bolts                       | .1 | All bolts, including those for the check valve and plug valve, shall be ASTM Type 316 Stainless Steel.  |
| 2.14 | Access Covers               | .1 | Access covers shall be designed to allow removal of the pumps from the stations without removing or damaging other equipment.   |
|      |                             | .2 | Each cover shall be hinged and include hydraulic assist for easy opening with less than 225 N lifting force and shall be provided with a padlock hasp with a box enclosure to prevent vandalizing of the lock.                          |



- .3 A brass padlock shall will be installed by the City at the developer's cost.
- .4 Each cover shall be provided with a positive means of locking open.
- .5 Safe-Hatch (or approved equal) shall be included to provide fall through protection.
- 2.15 Air Release Valve .1 Air release valve to be 50mm diameter NPT inlet, cast iron body, bronze mechanism and seat, stainless steel lever pins and float, designed for sewage, rated at 1MPa. Provide shut-off valve and back flushing facilities including blow-off valves and 3 metre long back flush hose. Equip valve and hose with quick disconnect couplings.
- 2.16 Floor Gratings .1 Fibreglass or Borden Type B aluminium Size No. 6 suitable for a bearing load of 5 kN/m<sup>2</sup>, or 200 kg plus dead weight of one pump whichever is greater.
- 2.17 Miscellaneous Metals .1 Aluminium: to ASTM 655.  
.2 conforming to CSA G40.2-M1977; Type W with yield strength of 300 MPa, shop primed.  
.3 stainless steel ASTM Type A316 Stainless Steel unless otherwise noted.  
.4 Miscellaneous metalwork, including brackets, nuts and bolts, cables, turnbuckles, and eye bolts shall be stainless steel or aluminium. Sharp edges and weld splatter shall be removed prior to installation.
- 2.18 Pressure Gauge .1 GIC #6211, liquid 100 mm diameter pressure gauge c/w snubber and isolating valve.
- 2.19 Hydrostatic Tests .1 Pressure piping within the FRP wet well and valve chamber shall be hydrostatically tested to a pressure no less than 1.5 x the shut off pressure of the lift station pumps. The test pressure shall be held for a period of not less than two (2) hours, with no leakage permitted.

Sewage forcemains external to the lift station shall be tested in accordance with Section 33 34 01 – Sewage Forcemains.

Should any test disclose leakage greater than that specified above, the Supplier shall locate and repair the defect and retest





|      |                                    |    |   |
|------|------------------------------------|----|---|
|      |                                    |    | the section to ensure that the leakage is within the allowable limits.  |
| 2.20 | Concrete Base and Anchoring System | .1 | The reinforced concrete wet well base and anchoring system shall be designed to prevent uplift of the fibreglass lift station assuming that the surrounding soil is flooded to finished ground elevation and that the station is empty. A minimum safety factor of 1.5 against uplift shall be used in the design of the base and anchoring system. |
| 2.21 | Power Supply and Controls          | .1 | As per Division 26.   |
| 3.0  | EXECUTION                          |    |   |
| 3.1  | Excavation and Backfilling         | .1 | To requirements of Section 31 23 01 Excavation, Trenching and Backfilling.  |
|      |                                    | .2 | Start backfilling only after the concrete has acquired a suitable degree of strength and only after obtaining written permission from the Contract Administrator. No backfilling of walls shall take place before the slabs have been cast and have reached a minimum of 75% design strength.   |
|      |                                    | .3 | Use only the approved portion of the excavated material and other approved imported granular fill.  |
|      |                                    | .4 | Deposit backfill in layers not exceeding 150mm thickness, and compact to obtain 95% of Standard Proctor Density or otherwise indicated on the Contract Documents.   |
|      |                                    | .5 | Keep heavy compacting equipment away from structure by at least 1.5 metres. This portion shall be compacted using hand operated tampers.  |
|      |                                    | .6 | Make all fills and embankments to elevations, contours, and slopes shown on the drawings.   |
|      |                                    | .7 | Grade top layer carefully to smooth regular surface, with a minimum thickness of 100mm of topsoil, when indicated on the drawings.  |
|      |                                    | .8 | Allow for any settlement which may occur in order that the finished fills or embankments will be to the final grades as shown on the drawings.  |



- .9 Excavate and remove all materials whatever their nature and condition to depths and dimensions necessary for the construction of the structure and piping to the limits shown on the drawings.
  - .10 Furnish all equipment for construction, temporary supports including shoring, bracing, cribs, coffer dams, etc. and for de-watering.
  - .11 Install and operate an adequate de-watering system for construction of the structures in the dry.
  - .12 All equipment used for de-watering and excavation shall be of a suitable and rugged type to assure continuous operation.
  - .13 Make special provisions to relieve the water pressure and prevent flotation or damage to parts of the works in case of accidental stoppage of de-watering equipment.
  - .14 Where over excavation is required, fill with specified sub-base or lean concrete unless otherwise indicated in the Contract Documents.
  - .15 Stockpile excavated granular material meeting backfill specification designated by the Contract Administrator. Save for re-use.
  - .16 Notify the Contract Administrator for inspection and approval after the excavation is completed.
  - .17 Do not place any concrete until the Contract Administrator has approved the depth of excavation and the character of the foundation material.
- 3.2 External Piping .1 To requirements of Sections 31 23 01 - Excavating, Trenching and Backfilling, Section 33 30 01 - Sanitary Sewers, and Section 33 34 01 - Sewage Forcemains.
- 3.3 Concrete Work .1 To Section 03 30 53 - Cast-in-Place Concrete and Section 03 20 01 - Concrete Reinforcement.
- 3.4 Electrical .1 To Division 26.
- 3.5 Piping Installation .1 Pipe shall be adequately supported on adjustable pipe saddle supports or from pie hangers or brackets during construction and completion to prevent abnormal stresses being imposed on items of equipment such as pump flanges.



- .2 Valves shall be installed in accordance with the manufacturer's recommendations.
  - .3 Before installing bolted connections, pipe ends, and gaskets shall be absolutely clean. Gaskets shall be lubricated with soapy water and bolts with thread lubricant. Bolts shall be tightened progressively by the crossover method and not in rotation around the joint. Bolts shall be torqued to the manufacturer's requirements. Wrenches used for tightening bolts shall be in good condition and properly sized to prevent rounding of nuts and bolt heads.
  - .4 During all stages of construction, piping shall be protected from damage from any cause. Openings in the piping system shall be securely covered, capped, or plugged to prevent collection of dirt, debris, or other extraneous matter during the entire construction.
  - .5 Damaged work shall be removed and replaced with new material to the satisfaction of the City.
- 3.6 Pumps and Accessories
- .1 Locate discharge elbows on the sump floor at exact locations required so that guide rails which connect from them to the access frame will be in perfect alignment.
  - .2 Firmly anchor discharge elbows to the floor at their proper location.
  - .3 Install guide rails.
  - .4 Lower pumps on guide rail system until contact is made with discharge elbows. Ensure that system functions to give leaktight connection.
- 3.7 Start-Up
- .1 Lift station shall be completed, including work of other sections, before start-up.
  - .2 Start-up of equipment to take place in the presence of a trained representative of the Equipment Supplier and City. Copies of final operating and maintenance manuals shall be provided to the City at least two (2) weeks in advance of start-up.
  - .3 Set level and align all equipment to the complete satisfaction of the City.
  - .4 Carefully check the operation and controls of the equipment.



- .5 Notify the City when the operation and controls of the equipment are satisfactory.
- .6 Provide the necessary facilities for the City to check the operation of the equipment.
- .7 The Contractor shall make provisions for adequate supply of water to the wet well and forcemain for testing purposes. Testing will include checking performance of all pumps, floats, and controls. At minimum the following tests will be conducted.
  - .1 Pump Condition - i.e. pump body, impeller running free, quick disconnect connection, cable connections, gaskets and oil level.
  - .2 Wet Well Condition - i.e. pump sliding free on guide rails, pump cable with sufficient slack, floats suitably positioned and will not snarl, no cable splices or junction box in the wet well, well clean.
  - .3 Control Panel Condition - i.e. components including motor overloads correctly rated for the pumps. Record over-load settings on schematic, date and sign.
  - .4 Start-Up Operation - i.e. supply voltage suitable, pump rotation correct, operation of pumps - by float switches - HOA selectors - lead pump selector - overloads isolate associated control, alarm float.
  - .5 Pump Load Checks - ie. load current on all phases for single and parallel pump operation, supply voltage under load. Confirm pumping rate and operating head.
  - .6 Alarm panel test to confirm all zones are correctly configured and operational.
- .8 Liaise with the Contract Administrator to ensure that the Design Engineer, the City, the Contractor, and the Equipment Supplier are present for the start-up and testing program.
- .9 The City will not take over operation and maintenance of any equipment until the work of all related sections has been completed in the area in which the equipment is located and all equipment has operated in its intended manner to the satisfaction of the City.



- .10 Cost of any temporary power costs for the start-up procedure shall be the responsibility of the Contractor.
- 3.8 Protection
  - .1 Protect the work and material of all other sections from damage and make good all damage thus caused, to the satisfaction of the City.
  - .2 Be responsible for work and equipment until finally inspected, tested, and accepted, protect work against theft, injury, or damage, and carefully store material and equipment received on site which are not immediately installed. Close open ends of work with temporary covers and plugs during construction to prevent entry of obstructing materials.
- 3.9 Cleaning
  - .1 Any dirt rubbish, or grease on walls, floors, or fixtures for which the Contractor is responsible must be removed and the premises left in first class condition in every respect.
  - .2 De-water station wet well and remove all dirt and grit from bottom of station.
- 3.10 Maintenance Manuals
  - .1 Supply three copies of hard backed bound manuals with all the information required for maintenance, operation, parts catalogue and lubrication.

The following information shall be included in the manual:

- .1 Table of contents.
- .2 As constructed shop drawings.
- .3 Equipment, layout drawings.
- .4 Electrical, control, and alarm wiring diagrams.
- .5 Normal and emergency operating instructions for all equipment.
- .6 Maintenance instructions for all equipment.
- .7 Safe work procedure for confined space entry into the wet well and valve chamber (to be prepared by a Qualified Professional).
- .8 Equipment data sheets.
- .9 Certified head/capacity curves for pumps.
- .10 Equipment part lists.
- .2 Each section shall be separated from the preceding section with a plasticized divider with a tab denoting contents of the section.
- .3 Review all of these instructions with the City representatives before the commencement of the maintenance period.



General catalogues will not be accepted and bulletins must deal specifically with the equipment provided.

**REFERENCE DOCUMENT 1**  
**WORKS AND SERVICES AGREEMENT**



TERMS OF INSTRUMENT - PART 2  
COVENANT

(Section 219 *Land Title Act*)

Agreement Number:

File Number:

**THIS AGREEMENT** is dated \_\_\_\_\_, \_\_\_\_\_ and is between

**THE CORPORATION OF THE CITY OF COURTENAY**

830 Cliffe Avenue  
Courtenay, BC V9N 2J7

(the "City")

OF THE FIRST PART

AND

***[name of Developer]***

(the "Developer")

OF THE SECOND PART

---

**WHEREAS**

- A. The Developer is the registered owner in fee simple of the lands in the City of Courtenay legally described in Item 2 of Part 1 of the *Land Title Act* Form C to which this Agreement is attached and which forms part of this Agreement (the "Land");
- B. The Developer has agreed to construct and provide certain works and services as required by the City's Subdivision and Development Servicing Bylaw No. XXXX, 2017, as amended, in accordance with the drawings, standards and specifications attached to this Agreement and in accordance with the applicable policies of the City;
- C. The Developer has applied for the approval of a subdivision or building permit in respect of the Land prior to the construction and installation of the required works and services and has agreed to enter into this Agreement with the City pursuant to Section 509(2) of the *Local Government Act*;





- D. The Developer has agreed to grant and transfer to the City all its right, title and interest in and to the works and services required to be constructed and installed, and the City has agreed to accept such transfer of the works and services on the terms of this Agreement; and
- E. The Developer has agreed to provide *security for completion* of the works and services.

**NOW THEREFORE** in consideration of payment of \$2.00 by the City to the Developer and other good and valuable consideration, the receipt of which is acknowledged by the Developer, the Developer covenants and agrees with the City in accordance with Section 219 of the *Land Title Act* as follows:

## DEFINITIONS

1. In this Agreement:

**“Accepted Drawings”** means the specifications, design drawings and other plans for the Works as referred to in Schedule “A” of this Agreement that are sealed by the Qualified Professional, and accepted in writing by the Development Engineer.

**“Bylaw”** means the City’s Subdivision and Development Servicing Bylaw No. XXXX, 2017, as amended or replaced from time to time.

**“Certificate of Construction Completion”** means written certification by the Development Engineer that the Works have been tested and are complete except for minor deficiencies specified in the certification, such that the Works are usable for their intended purpose, as determined by the Development Engineer acting reasonably.

**“Certificate of Acceptance”** means written certification by the Development Engineer under Section 5 of this Agreement that the Warranty Period in respect of the Works has been satisfactorily completed and ownership of the Works can be transferred to the City.

**“Complete” or Completion”** with respect to the Works means completion to the satisfaction of the Development Engineer evidenced by the Certificate of Construction Completion.

**“Construction Costs”** means the construction costs of Works and Services as estimated by the Qualified Professional and accepted by the Development Engineer.

**“Developer”** means the owner of land, or appointed agent for the owner, in respect of which a subdivision application or building permit application has been made.

**“Development Engineer”** means the person designated to that position by the City of Courtenay, or a designate.

**“Warranty Period”** means the period which expires on the later of one year after the date of issuance of the Certificate of Construction Completion and a later date established under section 5(c) of this Agreement



“**Qualified Professional**” means a Professional Engineer who is registered or licensed to practice in British Columbia under the *Engineers and Geoscientists Act*, who is responsible for the design, construction, supervision and certification of all Works on behalf of the Developer.

“**Security**” means cash or a clean, unconditional, irrevocable and automatically renewing letter of credit drawn on a chartered bank or credit union having a branch in the City at which demand may be made on the letter of credit.

“**Works**” means the works and services to be provided, performed and constructed by the Developer as required by the bylaws of the City or as otherwise required under statutory authority; without limitation, the Works include all the design and construction work described in Schedule “A” hereto, utilities and connections to be constructed on and off the Land, landscaping, environmental protection measures, provision of plans and registration of Land Title Office documents and plans.

## DEVELOPER’S COVENANTS

2. The *Developer* covenants and agrees with the City:
  - a) that the Land shall not be used except in accordance with this Agreement; and
  - b) that until such time as all the terms and conditions contained in sections 3, 4 and 8 are complied with, the Land and any buildings or structures erected or placed on or to be erected or placed on the Land shall not be used or occupied.
  
3. The *Developer* covenants and agrees:
  - a) not to commence the construction or installation of the *Works* without first receiving authorization to commence construction in writing from the *Development Engineer*;
  - b) to construct, install and *complete* the *Works* in accordance with the *Accepted Drawings*, with this Agreement and all applicable enactments;
  - c) to obtain the prior written consent of the *Development Engineer* for any changes to the *Accepted Drawings*;
  - d) to comply with any changes to the *Accepted Drawings* required by the *Development Engineer* as may be necessary to satisfy the *Development Engineer* that the *Works* function and operate in a manner satisfactory to the *Development Engineer*;
  - e) to comply with all statutes, laws, regulations and orders of any authority having jurisdiction and without limiting the generality of the foregoing all bylaws of the City; and
  - f) not to deposit or permit the deposit of any material or debris upon any highway or lands of the City, and if any material or debris is left upon a highways or land of the City during or after the construction of the *Works*, the City may remove the material or debris at the expense of the *Developer*.



4. Upon *completion* of the *Works*, the *Developer* covenants and agrees:
  - a) to assign to the City all of its right, title and interest in and to the *Works* not located on the Land unless in a City statutory right-of-way over the Land, free and clear of all encumbrances;
  - b) to grant or cause to be granted to the City in registerable form all statutory rights-of-way reasonably required by the *Development Engineer* for the operation, maintenance, repair and replacement of the *Works* located on the Land, on the City's standard terms; and
  - c) to deliver to the City all final inspection and testing records and as-constructed drawings of the *Works* which drawings shall be prepared by a professional engineer in accordance with the *Bylaw* and good engineering practice and be in a form satisfactory to the *Development Engineer* before issuance of the *Certificate of Acceptance*.
  
5. The *Developer* covenants and agrees :
  - a) to repair any deficiencies in design, materials or workmanship in the *Works* that may arise during the *Warranty Period*, including without limitation any deficiency of which the *Development Engineer* gives the *Developer* notice in writing;
  - b) that if the *Works* are in any way defective or do not operate in a satisfactory manner, the *Developer* shall, at the expense of the *Developer*, modify and reconstruct the *Works* immediately so that the *Works* are fully operative and function in accordance with the *Bylaw* standards, provided that any modification has been approved in writing by the *Development Engineer*;
  - c) that the *Development Engineer* may upon written notice to the *Developer*, given before the issuance of the *Certificate of Construction Completion*, increase the *Warranty Period* to a period the *Development Engineer* considers reasonable, in consideration of the period of time that is required to repair any deficiency in the *Works* of which the *Developer* has been given notice, but in any event not to exceed three years;
  - d) that if the *Developer* fails to remedy any defect or deficiency in the *Works* or pay for any damage resulting from the installation of the *Works*, the City may deduct from the *Security* the cost of repairing the *Works*, remedying any defect or deficiency or paying for any damage, and Section 10 of this Agreement shall apply.
  
6. The *Developer* authorizes the City, its agents and contractors to enter upon the Land at any time as may be necessary or convenient for the carrying out of this Agreement, including without limitation for the purpose of inspecting, repairing or undertaking the *Works*.

#### THE CITY'S COVENANTS

7. The City covenants and agrees that:



- a) it will permit the *Developer* to perform the *Works* on the terms and conditions contained in this Agreement and to occupy and use municipal highways and lands of the City as necessary for the construction of the *Works* as defined on the *Accepted Drawings*;
- b) it will issue a *Certificate of Construction Completion* signed by the *Development Engineer* upon the *Developer* satisfactorily completing the *Works*;
- c) during the *Warranty Period*, the City will operate and maintain those parts of the *Works* which are within a highway, municipal easement or municipal statutory right of way in the same manner and to the same standard as equivalent *works* are operated and maintained elsewhere in the City. Any costs attributable to any deficiency or defect in the *Works* or failure of the *Works* to operate normally shall be the responsibility of the *Developer*; and
- d) it will issue a *Certificate of Acceptance* signed by the *Development Engineer* upon the *Developer* satisfactorily completing the repair or correction of any defect or deficiency in the *Works* during the *Warranty Period* and performing all other requirements of this Agreement, i, and providing all final inspection records, testing records and as-constructed drawings.

#### TIME FOR COMPLETION OF WORKS

8. The *Developer* will *complete* the construction and installation of the *Works* to the satisfaction of the *Development Engineer* and obtain a *Certificate of Construction Completion* by **[insert date]**.

#### SECURITY

9. As a guarantee for the *Developer's* performance of all of its covenants and agreements contained in this Agreement, the *Developer* has deposited *Security*, in accordance with the *Bylaw*, in the sum of \$**[amount]** (the "Deposit"), which is equal to 125% of the estimated Construction Cost of the required *Works*, as certified by the *Qualified Professional*.
10. If the *Developer* does not *complete* the *Works* as required by Sections 3 and 8 of this Agreement, the City may, without notice to the *Developer*, *complete* the *Works* at the cost of the *Developer* and for that purpose the City may draw down upon the *Security* and hold or use the full amount of the *Security*. The City may undertake the *Works* either by itself or by contractors employed by it. The City shall be under no obligation to *complete* the *Works* and may undertake the *Works* in whole or in part, in the City's discretion as to extent and timing of *completion*.
11. If there are insufficient monies included in the *Security* to *complete* the *Works* in accordance with the *Accepted Drawings*, the *Developer* shall pay to the City the amount of the insufficiency immediately upon receipt of the City's invoice for that amount, whether or not the City has then completed the balance of the *Works*.
12. If:



- a) The *Developer* completes the *Works* as required by Section 3 and section 8 of this Agreement, and the *Certificate of Construction Completion* is issued by the City; or
- b) The City completes the *Works* in accordance with Section 10 of this Agreement at a cost which is less than the amount of the *Security*,

then the amount of the *Security* may be reduced by the *Development Engineer* to the sum of 5% of the *Security*, or \$1,000.00, whichever is greater, which amount shall be held by the City throughout the *Warranty Period* as *security* for the requirements in section 5.

13. The City shall return any unused part of the *Security* to the *Developer* without interest, not less than 60 days after issuance of the *Certificate of Acceptance*. Any return of *security* shall be made to the *Developer*, despite any change in ownership of the Land.
14. The *Development Engineer* may, not more than once in any three-month period, approve the *Developer's* request for a partial reduction in the amount of the *Security* as the construction of the *Works* proceeds, on the basis of a certification by the *Developer's Qualified Professional* that the portion of the *Works* to which the reduction relates has been completed to the standard specified in the *Bylaw* and in accordance with the *Accepted Drawings*, but not so as to reduce the amount of the *Security* below the amount mentioned in section 12. The *Development Engineer* may not approve a reduction under this section in relation to any portion of the *Works* in respect of which the *Development Engineer* has advised the *Developer* of a deficiency that has not been satisfactorily repaired.
15. If the City undertakes all or part of the *Works*, the cost of completing the *Works* which is payable by the *Developer* includes the City's actual cost of the construction and installation of them, together with engineering, supervision, legal, survey, contract administration, tendering, other professional services, interest and all other costs reasonably required for *completion* of the *Works*.

#### STANDARD OF THE WORKS

16. The *Developer* will construct and install or secure the *Works* to the standard required in the Engineering Divisions Design Standards and Specifications contained in the *Bylaw* and to the satisfaction of the *Development Engineer*.

#### DEVELOPER'S QUALIFIED PROFESSIONALS

17. The *Developer* represents and warrants that the *Works* have been, or will be, designed by a *Qualified Professional*.
18. The *Developer* acknowledges that the City has relied on cost estimates prepared by one or more *Qualified Professionals* in establishing the amount of the *Security* and that the *Developer* has so advised the *Qualified Professionals* prior to submission of those estimates to the City by the *Developer*.
19. At all times during the construction and provision of the *Works*, the *Developer* shall retain one or more *Qualified Professionals* to oversee the *completion* of the *Works*.



20. Any explanations, orders, instructions, directions and requests given by the City to the *Qualified Professional* shall be deemed to have been given to the *Developer*.
21. Upon *completion* of the *Works* and prior to issuance of the *Certificate of Construction Completion*, the *Developer's Qualified Professional* shall certify in writing that the *Works* have been constructed in accordance with the *Accepted Drawings*.

#### INDEMNIFICATION AND INSURANCE

22. The *Developer* shall indemnify and save harmless the City, its officers, employees, Council members, contractors and agents:
  - a) against all expenses and costs incurred as a result of bodily injury, death, property loss, property damage or other loss arising from the construction or provision of the *Works*;
  - b) against all expenses and costs which may be incurred by reason of liens, non-payment for labour or materials, Workers' Compensation assessments, employment insurance, federal or provincial tax, or union dues check off in respect of the construction or provision of the *Works*; and
  - c) from any claims, actions or proceedings relating to the construction, provision, maintenance or repair of the *Works* by the *Developer*, including defects in the *Works* and non-repair of the *Works*.

This indemnity shall survive any conclusion or other termination of this Agreement, in relation to any matter arising prior to expiry of the *Warranty Period*.

23. The *Developer* shall take out and maintain at all times from commencement of construction and installation of the *Works* until the *Development Engineer* issues a *Certificate of Acceptance*:
  - a) comprehensive general liability insurance against claims for bodily injury (including death) and property damage or loss arising from its carrying out the construction and installation of the *Works* (including failure to properly carry out or negligence in carrying out the *Works*), in an amount of not less than \$5,000,000.00 combined single limit per claim and with a per claim deductible of not more than \$5,000.00; and
  - b) builder's risk insurance, insuring the *Works* against loss or damage to the full replacement cost of the *Works*, and if the City elects to *complete* the *Works* as provided in this Agreement, the *Developer* is conclusively considered to have assigned the benefit of that insurance, and all proceeds of it, to the City.

The *Developer* must provide the *Development Engineer* with proof in writing of insurance before commencing the *Works* and again before the issuance of any *Certificate of Construction Completion*. All policies of insurance must name the City as an additional insured and contain a provision requiring the insurer to give the City 30 days' prior written notice before any alteration or cancellation of the policy is effective.



## MISCELLANEOUS

24. Nothing in this Agreement shall exempt the *Developer* of the Lands from the ordinary jurisdiction of the council of the City, its *bylaws* and regulations, and without limitation the construction of the *Works* shall not confer directly or indirectly any exemption or right of set-off from development cost charges, connection fees, application fees, user fees or other fee charge, except as statutorily required.
25. Where the singular or masculine is used in this Agreement it will be construed as the plural or feminine or neuter, as the case may be, and vice versa where the context or the parties so require.
26. This Agreement will be binding upon and will enure to the benefit of the parties, their successors and assigns.
27. The headings in this Agreement are for convenience of reference only and do not define or limit the scope or intent of this Agreement.
28. The Schedules to this Agreement form part of this Agreement.
29. The *Developer* acknowledges and agrees that the *Developer* relies exclusively on its own expertise, the *Developer's Qualified Professionals* and contractors and that the City does not, by its approvals, inspections or acceptance of the *Works*, warrant or represent that the *Works* are in compliance with any enactment or warrant the quality, fitness for purpose, adequacy or safety of the *Works*.
30. The *Developer* acknowledges that the City has made no representations, covenants, warranties, guarantees, promises or agreement with the *Developer* with regard to the subject matter of this Agreement, other than those in this Agreement.
31. The *Developer's* obligations and rights under this Agreement shall not be assigned without the written consent of the City, such consent not to be unreasonably withheld.
32. Every obligation and covenant of the *Developer* in this Agreement constitutes both a contractual obligation and a covenant granted under s.219 of the *Land Title Act* in respect of the Land and this Agreement burdens the Land and runs with it and binds the successors in title to the Land. This Agreement burdens and charges all of the Land and any parcel into which the Land is subdivided by any means and any parcel into which the Land is consolidated (including by removal of interior parcel boundaries) and shall be extended, at the *Developer's* cost, to burden and charge any land consolidated with the Land.
33. The *Developer* will, at the *Developer's* expense, do or cause to be done all acts reasonably necessary to register this Agreement against title to the Land with priority over all financial charges, liens and encumbrances registered or pending registration at the time of application for registration of this agreement against the title to the Land.





34. An alleged waiver of any breach of this Agreement is effective only if it is an express waiver in writing of the breach in respect of which the waiver is asserted. A waiver of a breach of this Agreement does not operate as a waiver of any other breach of this Agreement.
35. If any part of this Agreement is held to be invalid, illegal or unenforceable by a court having the jurisdiction to do so, that part is to be considered to have been severed from the rest of this Agreement and the rest of this Agreement remains in force unaffected by that holding or by the severance of that part.
36. This Agreement binds the parties to it and their respective successors, heirs, executors and administrators.
37. The parties hereto shall execute and do all such further deeds, acts, things and assurances that may be reasonably required to carry out the intent of this Agreement.
38. Time is of the essence of this Agreement.
39. Any notice to be given pursuant to this agreement must be in writing and delivered personally or sent by registered mail. The addresses of the parties for the purpose of notice are the addresses on the first page of this agreement and in the case of any subsequent *Developer*, the address will be the address shown on the title to the Land in the Land Title Office. If notice is delivered personally, it may be left at the relevant address in the same manner as ordinary mail is left by Canada Post and is to be deemed given when delivered. If notice is sent by mail, it will be considered given 5 days after mailing. In the case of any strike or other event causing disruption of ordinary Canada Post operations, a party giving notice for the purposes of this agreement must do so by delivery as provided in this section. A party may change its address for the purposes of this section by giving notice in accordance with this section.
40. By executing and delivering this Agreement each of the parties intends to create both a contract and a deed executed and delivered under seal.





**IN WITNESS WHEREOF** the parties hereto have executed this Agreement as of the day and year first above written.

|                         |   |                   |
|-------------------------|---|-------------------|
| SIGNED by an authorized | ) |                   |
| signatory of:           | ) |                   |
| “The Developer”         | ) |                   |
|                         | ) |                   |
|                         | ) |                   |
| in the presence of      | ) |                   |
|                         | ) |                   |
| _____                   | ) | _____             |
| Witness:                | ) | Name of Developer |

|                                |   |                                  |
|--------------------------------|---|----------------------------------|
| SIGNED by the authorized       | ) |                                  |
| signatories of <b>THE</b>      | ) |                                  |
| <b>CORPORATION OF THE CITY</b> | ) | _____                            |
| <b>OF COURTENAY</b>            | ) | Name                             |
|                                | ) | Mayor                            |
|                                | ) |                                  |
|                                | ) | _____                            |
|                                | ) | Name                             |
|                                | ) | Director of Legislative Services |



## Schedule "A" – Description of Required Works



## Schedule "B" – Calculation of Security

**REFERENCE DOCUMENT 2**  
**APPROVED PRODUCTS LIST**



**APPROVED PRODUCTS LIST**

This Reference Document lists materials and products that are either approved, restricted, or not allowed, for Works and Services performed within the City of Courtenay.

If a material or product is not listed in relation to an MMCD or a Supplementary Specification, any product meeting the requirements of such specification shall be accepted.

Where brand names are specified for a product, any proposal for an alternate product requires the approval of the Director of Engineering.

| MMCD Section    | Section Description                                | Product                               | Manufacturer   | Approved Model  | Restrictions/Additional Specifications  |
|-----------------|--|---------------------------------------|--|---|---|
| <b>03 40 01</b> | <b>Precast Concrete</b>                            |                                       |  |   |   |
|                 |  | Concrete Fence for Arterial Roads     | <ul style="list-style-type: none"> <li>American Technocrete</li> <li>Approved equal</li> </ul> | <ul style="list-style-type: none"> <li>Woodcrete Wall, Buffer Color</li> </ul>  | <ul style="list-style-type: none"> <li>Posts at 1.5m c/c</li> </ul>                   |
|                 |  | Concrete Fence for Wet Detention Pond | <ul style="list-style-type: none"> <li>American Technocrete</li> <li>Approved equal</li> </ul> | <ul style="list-style-type: none"> <li>Woodcrete Rail, Buffer Colour</li> </ul> | <ul style="list-style-type: none"> <li>Post at 2.44 c/c &amp; 2 Rail Fence</li> </ul> |
|                 |  | Concrete MSE Retaining Wall           | <ul style="list-style-type: none"> <li>Langley Precast</li> <li>Ocean Precast</li> </ul>       |   |   |
| <b>26 56 01</b> | <b>Roadway Lighting</b>                            |                                       |  |   |   |
|                 | <i>Products</i>                                    | LED Luminaires                        | <ul style="list-style-type: none"> <li>Philips</li> </ul>                                      | <ul style="list-style-type: none"> <li>Roadfocus</li> </ul>                     | 3000 K, RFS, RFM and RFL Series, as applicable  |
| <b>31 11 45</b> | <b>Shrub and Tree Preservation</b>                 |                                       |  |   |   |
|                 |  | Snow Fence                            | <ul style="list-style-type: none"> <li>Dupont</li> </ul>                                       | <ul style="list-style-type: none"> <li>L-70</li> </ul>                          |   |
| <b>32 92 19</b> | <b>Hydraulic Seeding</b>                           |                                       |  |   |   |
|                 | <i>Fertilizer</i>                                  |                                       | <ul style="list-style-type: none"> <li>Direct Solutions</li> </ul>                             | <ul style="list-style-type: none"> <li>20-2-16</li> </ul>                       |   |
| <b>32 93 01</b> | <b>Planting of Trees, Shrubs and Ground-covers</b> |                                       |  |   |   |
|                 |  | Tree Guy Anchors                      | <ul style="list-style-type: none"> <li>Tree Guy Systems</li> </ul>                             | <ul style="list-style-type: none"> <li>Arrow Anchor</li> </ul>                  |   |
|                 |  | Tree Trunk Protection                 | <ul style="list-style-type: none"> <li>Deep Roots Products</li> </ul>                          | <ul style="list-style-type: none"> <li>Arborgard</li> </ul>                     |   |
|                 |  | Tree Ties                             | <ul style="list-style-type: none"> <li>Deep Roots Products</li> </ul>                          | <ul style="list-style-type: none"> <li>Arbor Tie</li> </ul>                     |   |
|                 | <b>Misc. Products</b>                              | Root Barrier                          | <ul style="list-style-type: none"> <li>deeproot</li> </ul>                                     | <ul style="list-style-type: none"> <li>UB 18-2</li> </ul>                       |   |
|                 |  | Adhesive                              | <ul style="list-style-type: none"> <li>OSI Sealants</li> </ul>                                 | <ul style="list-style-type: none"> <li>PL 200</li> </ul>                        |   |
|                 |  | Drain Mat                             | <ul style="list-style-type: none"> <li>Nilex Geotextile</li> </ul>                             | <ul style="list-style-type: none"> <li>Nudrain WD/15</li> </ul>                 |   |
|                 |  | Filter Fabric                         | <ul style="list-style-type: none"> <li>Nilex Geotextile</li> </ul>                             | <ul style="list-style-type: none"> <li>Nilex 4545</li> </ul>                    |   |



| MMCD Section     | Section Description                | Product   | Manufacturer  | Approved Model   | Restrictions/Additional Specifications   |
|------------------|------------------------------------|---|---|--|--|
| <b>32 94 015</b> | <b>Irrigation System</b>           |   |   |  |  |
|                  | <b>Backflow Prevention Device</b>  |   | <ul style="list-style-type: none"> <li>Watts</li> </ul>                                   | <ul style="list-style-type: none"> <li>Model 007-QT</li> </ul>                                       |  |
|                  | <b>Electronic Control Valves</b>   |   | <ul style="list-style-type: none"> <li>Rain Bird</li> </ul>                               | <ul style="list-style-type: none"> <li>EFB CP Series Brass</li> <li>300 BPES Series Brass</li> </ul> | <ul style="list-style-type: none"> <li>&lt; 75mm</li> <li>≥ 75mm</li> </ul>  |
|                  | <b>Master Valve</b>                |   | <ul style="list-style-type: none"> <li>Rain Bird</li> </ul>                               | <ul style="list-style-type: none"> <li>EFB CP Series Brass</li> <li>300 BPES Series Brass</li> </ul> | <ul style="list-style-type: none"> <li>&lt; 75mm</li> <li>≥ 75mm</li> </ul>  |
|                  | <b>Pressure Regulating Modules</b> |   | <ul style="list-style-type: none"> <li>Toro</li> <li>Rain Bird</li> </ul>                 | <ul style="list-style-type: none"> <li>EZR-100</li> <li>PRS-Dial</li> </ul>                          |  |
|                  | <b>Automatic Controllers</b>       |   | <ul style="list-style-type: none"> <li>Toro</li> </ul>                                    | <ul style="list-style-type: none"> <li>Sentinel Satellite Controller</li> </ul>                      |  |
|                  | <b>Control Wire</b>                | Wire  | <ul style="list-style-type: none"> <li>Paige Wire</li> </ul>                              | <ul style="list-style-type: none"> <li>P7079D</li> </ul>   | <p>Common Wire to be min. 14-gauge</p> <p>Master Valve Wire to be min. 14-gauge</p>  |
|                  |                                    | Flow / pulse transmitter wiring                                     | <ul style="list-style-type: none"> <li>Belden</li> </ul>                                  | <ul style="list-style-type: none"> <li>PE39</li> </ul>   | <p>8mm Aluminum Polyester Shield</p> <p>Black HDPE Jacket</p>  |
|                  |                                    | Wire splice   | <ul style="list-style-type: none"> <li>3M</li> </ul>                                      | <ul style="list-style-type: none"> <li>DBY connector</li> </ul>                                      |  |
|                  | <b>Sprinkler Heads</b>             |   | <ul style="list-style-type: none"> <li>Toro</li> <li>Rain Bird</li> <li>Hunter</li> </ul> |  | <p>Additions to existing irrigation systems to be same product</p>   |
| <b>33 11 01</b>  | <b>Waterworks</b>                  |   |   |  |  |
|                  | <b>Water Main Ductile Iron</b>     | <ul style="list-style-type: none"> <li>Ductile Iron</li> </ul>      | <ul style="list-style-type: none"> <li>McWane Group</li> <li>US Pipe</li> </ul>           |  | <p>CL 50 for all mains less than 400mm dia. and Pressure Class 350 for all mains larger than 400mm dia.</p>  |
|                  | <b>Water Main PVC</b>              | <ul style="list-style-type: none"> <li>PVC</li> <li>PVCO</li> </ul> | <ul style="list-style-type: none"> <li>Ipex</li> <li>Royal Pipe Systems</li> </ul>        | <ul style="list-style-type: none"> <li>Blue Brute</li> <li>Seal</li> <li>Bionax</li> </ul>           | <p>PVC pipe to AWWA C900 / C 905/ C 909 – 100 mm to 300 mm diameter</p> <p>DR18 Minimum. Compliance with MMCD updated Section 33 11 01 2.2.2.2 for thickened bell and spigot pipe</p> <p>All PVC / PVCO water mains shall be pigmented blue.</p> <p>Nitro gasket shall be used when hydro carbon is encountered in surrounding soil.</p> |



| MMCD Section | Section Description                           | Product   | Manufacturer   | Approved Model  | Restrictions/Additional Specifications   |
|--------------|---|---|--|---|--|
|              |   |   |  |   | Bionax to be accepted for use in seismic condition   |
|              | <b>Water Main HDPE</b>                        | <ul style="list-style-type: none"> <li>HDPE</li> </ul>              | <ul style="list-style-type: none"> <li>KWH Pipe</li> <li>Isco Pipe</li> <li>Polytubes</li> </ul>   | <ul style="list-style-type: none"> <li>Sclairpipe</li> <li>WL Plastics</li> </ul>   | AWWA C 153<br>AWWA C110  |
|              | <b>Water Main Fitting Ductile Iron</b>        | <ul style="list-style-type: none"> <li>Ductile Iron</li> </ul>      | <ul style="list-style-type: none"> <li>Terminal City Iron Works</li> <li>Sigma</li> </ul>  |   |  |
|              | <b>PVC Injection Molded Fittings</b>          | <ul style="list-style-type: none"> <li>PVC</li> <li>PVCO</li> </ul> | <ul style="list-style-type: none"> <li>IPEX</li> <li>Royal</li> </ul>  |   |  |
|              | <b>PVC Fabricated Fittings</b>                | <ul style="list-style-type: none"> <li>PVC</li> <li>PVCO</li> </ul> | <ul style="list-style-type: none"> <li>IPEX</li> <li>Pro-line</li> <li>Galaxy Plastics</li> </ul>  |   |  |
|              | <b>Nuts and Bolts</b>                         | Stainless Steel ASTM A194 type 304                                  |  |   |  |
|              | <b>Tie Rod</b>                                | Zinc or Cadmium Plated ASTM A354 Grade BC Steel                     | <ul style="list-style-type: none"> <li>Cor-ten Steel</li> </ul>  |   |  |
|              | <b>Couplings and Flange Coupling Adapters</b> | Plain End Coupler   | <ul style="list-style-type: none"> <li>Robar</li> <li>Smith-Blair</li> <li>Romac</li> <li>Mueller</li> <li>Ford</li> </ul>               | <ul style="list-style-type: none"> <li>Robar 1408</li> <li>Smith-Blair441</li> <li>Romac 501</li> <li>Mueller MRC</li> <li>Ford FC1</li> </ul>  |  |
|              |   | Flanged Adapter   | <ul style="list-style-type: none"> <li>Robar</li> <li>Smith-Blair</li> <li>Romac</li> <li>Mueller</li> <li>EBAA</li> <li>Clow</li> </ul> | <ul style="list-style-type: none"> <li>Robar 7404/6</li> <li>Smith-Blair912</li> <li>Romac</li> <li>Mueller</li> <li>EBAA Iron 1000</li> <li>Clow Series 40, DI</li> <li>Clow Series 90, PVC</li> </ul> |  |
|              |   | Restrained Flange Adaptors  | <ul style="list-style-type: none"> <li>Romac</li> <li>Uniflange</li> <li>EBAA</li> </ul>   | <ul style="list-style-type: none"> <li>Romac RFCA</li> <li>Uniflange RFAP</li> <li>EBAA 2100</li> </ul>   |  |
|              |   | Repair Clamps   | <ul style="list-style-type: none"> <li>Canpac</li> <li>Mueller</li> <li>Robar</li> <li>Clow</li> <li>Romac</li> </ul>                    | <ul style="list-style-type: none"> <li>Canpac CR-2</li> <li>Mueller 520</li> <li>Robar 400 and 1500</li> <li>Clow 100, 200, 300</li> <li>Romac SS2</li> </ul>   | Repair clamps shall be stainless steel   |
|              | <b>Joint Restraint Ductile Iron Mains</b>     |   | <ul style="list-style-type: none"> <li>UniFlange Series 1400</li> <li>EBAA Iron</li> <li>Clow</li> </ul>                                 | <ul style="list-style-type: none"> <li>UniFlange Series 1400</li> <li>EBAA Iron Megalug1700</li> <li>Clow Tufgrip TDG</li> </ul>  | All joint restraints shall have a pressure rating equal or greater than the mainline pipe. |



| MMCD Section | Section Description                        | Product                         | Manufacturer   | Approved Model   | Restrictions/Additional Specifications   |
|--------------|--|---------------------------------|--|--|--|
|              | <b>Joint Restraint PVC / PVCO Mains</b>    |                                 | <ul style="list-style-type: none"> <li>UniFlange</li> <li>EBAA Iron</li> <li>Romac</li> </ul>                                      | <ul style="list-style-type: none"> <li>UniFlange Series 1300</li> <li>EBAA Iron MJ Series 1500</li> <li>EBAA Iron 1900</li> <li>Romac Alpha</li> </ul> | No wedge action type for PVC or PVCO pipes. Restraint systems for PVC or PVCO pipe shall be approved by the pipe manufacturer to not reduce the pipe recommended working pressure. |
|              | <b>Restrained Joint Pipe Systems (PVC)</b> |                                 | <ul style="list-style-type: none"> <li>Ipex</li> <li>Royal</li> </ul>  | <ul style="list-style-type: none"> <li>Ipex Terra Brute</li> <li>Royal Cobra Lock</li> </ul>   |  |
|              | <b>Restrained Joint Pipe Systems (DI)</b>  |                                 | <ul style="list-style-type: none"> <li>US Pipe</li> <li>McWane</li> </ul>  | <ul style="list-style-type: none"> <li>Field-Lok Gasket</li> <li>SureStop Gasket</li> </ul>  |  |
|              | <b>Valves and Valve Boxes</b>              | 75 mm – 300 mm Resilient-seated | <ul style="list-style-type: none"> <li>Mueller</li> <li>Clow Canada</li> <li>AVK</li> <li>Dobney</li> <li>Terminal City</li> </ul> | <ul style="list-style-type: none"> <li>Mueller A2362</li> <li>Clow 6100</li> <li>AVK</li> </ul>  | All valves shall have epoxy coated ductile iron body with Stainless Steel Bolts  |
|              | <b>Blowoff Valve</b>                       | 50mm Resilient Seat Gate Valve  | <ul style="list-style-type: none"> <li>AVK</li> <li>Mueller</li> <li>Clow</li> </ul>   | <ul style="list-style-type: none"> <li>AVK</li> <li>Mueller A2360</li> <li>Clow F6103</li> </ul>   |  |
|              | <b>Air Valve</b>                           |                                 | <ul style="list-style-type: none"> <li>Apco</li> <li>Val-Matic</li> <li>Crispin</li> </ul>   | <ul style="list-style-type: none"> <li>APCO 143C</li> <li>Val-Matic 201C</li> <li>Crispin UL</li> </ul>  | Internally Coated  |
|              | <b>Water Valve Box</b>                     |                                 | <ul style="list-style-type: none"> <li>Terminal City</li> <li>Dobney</li> <li>Sigma</li> </ul>                                     |  | Square type Cover shall be marked with "Water".  |
|              | <b>Curb Stop Box</b>                       |                                 | <ul style="list-style-type: none"> <li>Dobney</li> <li>Trojan</li> <li>Mueller</li> </ul>  |  | Square type Cover shall be marked with "Water".  |
|              | <b>Joint Protection</b>                    | Petrolatum Tape & Mastic        | <ul style="list-style-type: none"> <li>Petrowrap</li> <li>Trenton Tec Tape</li> <li>Denso</li> </ul>                               |  | AWWA C209<br>AWWA C214<br>AWWA C217-90   |
|              | <b>Water Service Connection</b>            | Type K Copper – 19mm to 75mm    |  |  | ASTM B88M  |
|              |  | Polyethylene                    | <ul style="list-style-type: none"> <li>Rehau</li> </ul>  | <ul style="list-style-type: none"> <li>Rehau Municipex (PexA)</li> </ul>   | With 10 Gauge Tracer Wire (AWG)  |
|              | <b>Saddles for Ductile Iron Mains</b>      |                                 | <ul style="list-style-type: none"> <li>Robar</li> <li>Canpac</li> <li>Mueller</li> <li>Romac</li> </ul>                            | <ul style="list-style-type: none"> <li>Robar 2406/8</li> <li>Canpac 313</li> <li>Mueller DR2A</li> <li>Romac 202BS</li> </ul>                          |  |
|              | <b>Saddles for PVC / PVCO Main</b>         |                                 | <ul style="list-style-type: none"> <li>Canpac</li> <li>Robar</li> <li>Cambridge Brass</li> </ul>                                   | <ul style="list-style-type: none"> <li>Series 81Z</li> </ul>   | Saddles required for service installation on all PVC / PVCO mains - Bronze body with stainless steel straps  |





| MMCD Section | Section Description                           | Product   | Manufacturer   | Approved Model  | Restrictions/Additional Specifications  |
|--------------|---|---|--|---|---|
|              | <b>Tapping Sleeve for PVC</b>                 |   | <ul style="list-style-type: none"> <li>Ford Meter Box</li> <li>JCM</li> <li>Romac</li> </ul>                     | <ul style="list-style-type: none"> <li>Ford FS313</li> <li>JCM 422 Series</li> <li>SST Series</li> </ul>                                  |   |
|              | <b>Abandon Service Sleeve</b>                 |   | <ul style="list-style-type: none"> <li>Robar</li> </ul>  | <ul style="list-style-type: none"> <li>6636AS</li> </ul>  | NC T 304 SS Const   |
|              | <b>Hydrant</b>                                |   | <ul style="list-style-type: none"> <li>Terminal City</li> <li>Mueller Co.</li> <br/> <li>AVK</li> </ul>          | <ul style="list-style-type: none"> <li>C71P – H105</li> <li>Modern Centurion (A-442)</li> <li>2780</li> </ul>                             | Must have 100mm Storz fitting on pumper port<br>Paint colours shall be as follows: <ul style="list-style-type: none"> <li>Red body</li> <li>White top</li> <li>2 white side ports</li> <li>black Storz</li> </ul> |
|              | <b>Corporation Stop</b>                       | Full Port Ball Valve  | <ul style="list-style-type: none"> <li>Cambridge</li> <li>Ford</li> <li>Mueller</li> <li>Al-MacDonald</li> </ul> | <ul style="list-style-type: none"> <li>Cambridge 301</li> <li>Ford FB600</li> <li>Mueller B25008</li> <li>Al-MacDonald 4700</li> </ul>    | Shall be full-port ball valve to 50 mm only.<br>Use mainline gate valve for sizes >50 mm  |
|              | <b>Curb Stop</b>                              | Full Port Ball Valve  | <ul style="list-style-type: none"> <li>Cambridge</li> <li>Ford</li> <li>Mueller</li> <li>Al-MacDonald</li> </ul> | <ul style="list-style-type: none"> <li>Cambridge 202</li> <li>Ford B44-343G</li> <li>Mueller B25209</li> <li>Al-MacDonald 6100</li> </ul> | Shall be full-port ball valve to 50 mm with 90° turn stop.<br>Use mainline gate valve for larger sizes > 50mm   |
|              | <b>Meter Setters</b>                          |   | <ul style="list-style-type: none"> <li>Cambridge Brass</li> </ul>  | <ul style="list-style-type: none"> <li>1" 6031 Series</li> <li>1 ½" – 2" 6020 series</li> </ul>   |   |
|              | <b>Idler Bar</b>                              |   | <ul style="list-style-type: none"> <li>Cambridge Brass</li> </ul>  | <ul style="list-style-type: none"> <li>450 Plastic (25mm Service Connection)</li> <li>450NL Copper (50mm Service Connection)</li> </ul>   |   |
|              | <b>Meter Pits</b>                             |   | <ul style="list-style-type: none"> <li>Langley Concrete</li> <li>AE Concrete</li> <li>Armtec</li> </ul>          | <ul style="list-style-type: none"> <li>B937 with cast iron Lid for 25mm</li> <li>5686 with steel lid for 50mm</li> </ul>                  | Full Circumferential models only.   |
|              | <b>Meter Chambers</b>                         |   | <ul style="list-style-type: none"> <li>Armtec</li> </ul>   | <ul style="list-style-type: none"> <li>2121.5</li> </ul>  | With Aluminum spring assisted double lids.  |
|              | <b>Casing Spacers</b>                         | As shown on contract drawings   | <ul style="list-style-type: none"> <li>Uniflange</li> <li>Calpico</li> <li>APS</li> </ul>                        | <ul style="list-style-type: none"> <li>Uniflange</li> <li>Calpico</li> <li>APS Casing Spacers</li> </ul>                                  | Shall be fabricated cast iron or high density polyethylene insulating spacers designed to center main in the carrier pipe   |
|              | <b>Pressure Reducing Valve Stations (PRV)</b> | <ul style="list-style-type: none"> <li>PRV Valve</li> <li>Limit Switch Indicator</li> <li>Valve Position Indicator</li> </ul> | <ul style="list-style-type: none"> <li>Singer</li> <li>Singer</li> <br/> <li>Singer</li> </ul>                   | <ul style="list-style-type: none"> <li>Singer 106-PR</li> <li>Singer X129</li> <br/> <li>Singer X156</li> </ul>                           | Epoxy coated  |



| MMCD Section                      | Section Description                      | Product  | Manufacturer  | Approved Model  | Restrictions/Additional Specifications  |
|-----------------------------------|--|--|---|---|---|
|                                   |  | <ul style="list-style-type: none"> <li>• Strainer</li> <li>• Domestic flow indicator</li> <li>• Pressure Transducer</li> <li>• PLC</li> <li>• HMI</li> <li>• Router</li> </ul> | <ul style="list-style-type: none"> <li>• Singer</li> <li>• Singer</li> <li>• Emerson-Rosemount</li> <li>• Scadapack</li> <li>• Maple Systems, or equivalent</li> <li>• SonicWall</li> </ul> | <ul style="list-style-type: none"> <li>• J1521M Arion Strainer</li> <li>• SPI-MV Flow Meter</li> <li>• 2088</li> <li>• Scadapack 334</li> </ul> |   |
| <b>33 30 01 Sanitary Sewers</b>   |  |  |   |   |   |
|                                   | <b>Concrete</b>                          |  |   |   | Not permitted   |
|                                   | <b>PVC Pipe, Mainline Smooth Profile</b> | PVC SDR35  | <ul style="list-style-type: none"> <li>• IPEX</li> <li>• Royal</li> <li>• Diamond</li> <li>• JM Eagle</li> <li>• Northern Pipe Products</li> </ul>  | <ul style="list-style-type: none"> <li>• IPEX Ring-Tite</li> <li>• Royal Seal</li> <li>• Diamon Sani-21</li> </ul>                              | Sizes > than 750 mm to be approved by the City  |
|                                   | <b>Sanitary Service Connection</b>       | PVC SDR35<br>Min 100mm diameter  | <ul style="list-style-type: none"> <li>• IPEX</li> <li>• Royal</li> <li>• Diamond</li> <li>• JM Eagle</li> <li>• Northern Pipe Products</li> </ul>  | <ul style="list-style-type: none"> <li>• IPEX Ring-Tite</li> <li>• Royal Seal</li> <li>• Diamon Sani-21</li> </ul>                              | New PVC main: use manufactured wyes.<br>New HDPE mains: Use injection molded PVC manufactured wyes for mains < 300<br>Other mains: use strap saddles. |
|                                   | <b>Inspection Chamber</b>                | Inspection Chamber   | <ul style="list-style-type: none"> <li>• Le-Ron Plastics Inc.</li> <li>• Pro-line</li> <li>• Galaxy Plastics</li> </ul>   |   |   |
|                                   |  | Inspection Chamber Back-flow check valve   | <ul style="list-style-type: none"> <li>• Le-Ron Plastics Inc.</li> <li>• Pro-line</li> <li>• Galaxy Plastics</li> </ul>   |   |   |
|                                   | <b>Service Connection Boxes</b>          |  | <ul style="list-style-type: none"> <li>• Brooks</li> </ul>  | <ul style="list-style-type: none"> <li>• Series 37</li> </ul>   | Full Circumferential models only.   |
|                                   | <b>Repair Couplers</b>                   |  | <ul style="list-style-type: none"> <li>• Rollee, Fernco, Shear Band</li> </ul>  | <ul style="list-style-type: none"> <li>• Rollee, Fernco, Shear Band</li> </ul>  | Couplers shall have appropriate adaptor gaskets to suit OD of pipe material being coupled   |
| <b>33 34 01 Sewage Forcemains</b> |  |  |   |   |   |
|                                   | <b>Pipes, Joints and Fittings</b>        | Fused PVC  | <ul style="list-style-type: none"> <li>• IpeX</li> <li>• Royal</li> </ul>   |   |   |
|                                   |  | HDPE with fusion welded joints   | <ul style="list-style-type: none"> <li>• Sclairpipe</li> <li>• Drisco Pipe</li> <li>• ISCO Pipe</li> </ul>  | <ul style="list-style-type: none"> <li>• Sclairpipe</li> <li>• DriscoPlex</li> <li>• WL Plastics</li> </ul>                                     | AWWA C906   |
|                                   | <b>Valves</b>                            | Air Valves   | <ul style="list-style-type: none"> <li>• ARI</li> </ul>   |   |   |
|                                   | <b>Valve Chamber</b>                     |  | <ul style="list-style-type: none"> <li>• Dobney</li> </ul>  | Dobney C20  |   |



| MMCD Section                             | Section Description                     | Product   | Manufacturer  | Approved Model  | Restrictions/Additional Specifications   |
|--|---|---|---|---|--|
| <b>33 40 01 Storm Sewers</b>             |   |   |   |   |  |
|  | <b>Concrete Pipe</b>                    | Non-reinforced Concrete C14-3<br>Reinforced Concrete C76-III, IV, and V | <ul style="list-style-type: none"> <li>Langley Concrete and Tiles</li> <li>Ocean Pipe</li> </ul>                                |   | PPP or Q-Cast Certified  |
|  | <b>PVC Pipe, Mainline Smooth Wall</b>   | PVC SDR35   | <ul style="list-style-type: none"> <li>IPEX</li> <li>Royal</li> <li>Diamond</li> <li>JM Eagle</li> <li>Northern Pipe</li> </ul> | <ul style="list-style-type: none"> <li>IPEX Ring-Tite</li> <li>Royal Seal</li> <li>Diamond Sani-21</li> </ul> | Sizes > than 750 mm to be approved by the City Engineer  |
|  | <b>PVC Pipe, Mainline Profile</b>       |   | <ul style="list-style-type: none"> <li>Ipex</li> <li>Royal</li> </ul>   | <ul style="list-style-type: none"> <li>Ipex UltraRib</li> <li>Royal Korflo</li> </ul>                         | Concentric ribbed pipe only is permitted to 900 mm, No spiral ribbed pipe will be allowed.   |
|  | <b>HDPE Pipe, Mainline Open Profile</b> |   | <ul style="list-style-type: none"> <li>Armtec</li> <li>ADS</li> </ul>   | <ul style="list-style-type: none"> <li>Armtec Boss 2000</li> <li>ADS N-12</li> </ul>                          |  |
|  | <b>Service Connection</b>               | PVC SDR28<br>Min 150mm diameter   | <ul style="list-style-type: none"> <li>IPEX</li> <li>Royal</li> <li>Diamond</li> <li>JM Eagle</li> <li>Northern Pipe</li> </ul> | <ul style="list-style-type: none"> <li>IPEX Ring-Tite</li> <li>Royal Seal</li> <li>Diamond Sani-21</li> </ul> | New PVC main: use manufactured wyes.<br>New concrete main: use PVC stub with bell, pre-cemented with epoxy resin.<br>New HDPE mains: Use injection molded PVC manufactured wyes for mains < 300<br>Other mains: use strap saddles. |
|  | <b>Inspection Chamber</b>               | Inspection Chamber  | <ul style="list-style-type: none"> <li>Le-Ron Plastics Inc.</li> <li>Pro-line</li> <li>Galaxy Plastics</li> </ul>               |   |  |
|  | <b>Service Connection Boxes</b>         |   | <ul style="list-style-type: none"> <li>Brooks</li> </ul>  | <ul style="list-style-type: none"> <li>Series 37</li> </ul>   | Full Circumferential models only.  |
| <b>33 42 13 Pipe Culverts</b>            |   |   |   |   |  |
|  | <b>End Walls</b>                        | Concrete  | <ul style="list-style-type: none"> <li>Langley Concrete and Tiles</li> <li>Ocean Pipe</li> </ul>                                |   | Q-Cast Certified<br>PPP Certified  |
|  |   | Fiberglass Composite  | <ul style="list-style-type: none"> <li>CIF Composites</li> </ul>  | <ul style="list-style-type: none"> <li>Ecolite</li> </ul>   |  |
|  |   | Mechanically Stabilized Earth (MSE)                                     | <ul style="list-style-type: none"> <li>Flex MSE</li> </ul>  | <ul style="list-style-type: none"> <li>Flex MSE</li> </ul>  |  |
| <b>33 44 01 Manholes and Catchbasins</b> |   |   |   |   |  |
|  | <b>Manhole Frame and Cover</b>          | Cast Iron   | <ul style="list-style-type: none"> <li>Dobney</li> <li>Westview Sales Ltd.</li> </ul>   | <ul style="list-style-type: none"> <li>Dobney</li> <li>Westview Sales Ltd.</li> </ul>                         | Sanitary Sewer manhole lids shall be marked "SANITARY SEWER"   |



| MMCD Section    | Section Description                           | Product                               | Manufacturer  | Approved Model  | Restrictions/Additional Specifications                 |
|-----------------|---|---------------------------------------|---|---|--|
|                 |   |                                       |   |   | Storm Sewer manhole lids shall be marked "STORM SEWER" |
|                 | <b>Catch Basin and Other Castings</b>         | CB Frame                              | <ul style="list-style-type: none"> <li>Dobney</li> <li>Westview Sales Ltd.</li> </ul>         | <ul style="list-style-type: none"> <li>B50</li> </ul>   |  |
|                 |   | CB Grate                              | <ul style="list-style-type: none"> <li>Dobney</li> <li>Westview Sales Ltd.</li> </ul>         | <ul style="list-style-type: none"> <li>B50</li> </ul>   |  |
|                 |   | Lawn Basin Grate (1050mm Barrel)      | <ul style="list-style-type: none"> <li>Dobney</li> <li>Westview Sales Ltd.</li> </ul>         |   |  |
|                 | <b>Hydro-dynamic grit Separator</b>           |                                       | <ul style="list-style-type: none"> <li>Langley Concrete and Tiles</li> <li>Contech</li> </ul> | <ul style="list-style-type: none"> <li>Stormceptor</li> <li>Vorsentry</li> <li>CDS</li> </ul>                     |  |
| <b>33 49 23</b> | <b>Storm Drainage Water Retention Systems</b> |                                       |   |   |  |
|                 | <b>Polypropylene Arched Chamber</b>           |                                       | <ul style="list-style-type: none"> <li>ADS</li> </ul>   | <ul style="list-style-type: none"> <li>Stormtech</li> </ul>   |  |
|                 | <b>Polyethylene Arched Chamber</b>            |                                       | <ul style="list-style-type: none"> <li>Contech</li> </ul>                                     | <ul style="list-style-type: none"> <li>Chambremaxx</li> </ul>   |  |
|                 |   |                                       | <ul style="list-style-type: none"> <li>Brentwood Industries</li> </ul>                        | <ul style="list-style-type: none"> <li>Stormtank</li> </ul>   |  |
| <b>34 41 13</b> | <b>Traffic Signals</b>                        |                                       |   |   |  |
|                 |   | Siren Activated Emergency Pre-emption | <ul style="list-style-type: none"> <li>Traffic Systems LLC</li> </ul>                         | <ul style="list-style-type: none"> <li>Sonem 2000</li> </ul>  |  |
|                 |   | Audible Signals                       | <ul style="list-style-type: none"> <li>Polara Enterprises</li> </ul>                          | <ul style="list-style-type: none"> <li>Navigator APS</li> </ul>   |  |
|                 |   | LED Luminaires                        | <ul style="list-style-type: none"> <li>Philips</li> </ul>                                     | <ul style="list-style-type: none"> <li>Roadfocus</li> </ul>   | 3000 K, RFS, RFM and RFL Series, as applicable         |
|                 |   | Traffic Controllers                   | <ul style="list-style-type: none"> <li>Econolite</li> </ul>                                   | <ul style="list-style-type: none"> <li>Cobalt</li> </ul>  |  |
|                 | <b>Sanitary Lift Station Components</b>       |                                       |   |   |  |
|                 | Standards for Sanitary Lift Stations          | Submersible Pumps                     | <ul style="list-style-type: none"> <li>Flygt</li> </ul>                                       |   | Non-Clogging   |
|                 |   | Flush Valve                           | <ul style="list-style-type: none"> <li>Flygt</li> </ul>                                       | Model 4901  | Or Approved Equal                                      |
|                 |   | Wet Well                              | <ul style="list-style-type: none"> <li>Xylem</li> </ul>                                       |   | Engineered & Prefabricated                             |
|                 |   | Portable Lifting Davit                | <ul style="list-style-type: none"> <li>DBI SALA</li> </ul>                                    | <ul style="list-style-type: none"> <li>8510311 w/ Davit Arm</li> <li>8517412 including tie off 8516691</li> </ul> |  |
|                 |   | HMI                                   | <ul style="list-style-type: none"> <li>To be confirmed by the City</li> </ul>                 |   |  |
|                 |   | Controller                            | <ul style="list-style-type: none"> <li>Xylem</li> </ul>                                       | MultiSmart  |  |



| MMCD Section | Section Description | Product        | Manufacturer   | Approved Model      | Restrictions/Additional Specifications    |
|--------------|---------------------|----------------|--|---------------------|---|
|              |                     | SCADA          | <ul style="list-style-type: none"><li>Flygt / Allied Control Systems</li></ul> |                     | Must be compatible with City Scada system |
|              |                     | Float Switches | <ul style="list-style-type: none"><li>Xylem</li></ul>                          | tree type (mercury) | Or Approved Equal (must be CSA certified) |



**THE CORPORATION OF THE CITY OF COURTENAY**

**BYLAW NO. 2870**

**A bylaw to amend Zoning Bylaw No. 2500, 2007**

The Council of the Corporation of the City of Courtenay in open meeting assembled enacts as follows:

1. This bylaw may be cited for all purposes as **“Zoning Amendment Bylaw No. 2870, 2017”**.
2. That “Zoning Bylaw No. 2500, 2007” be hereby amended as follows:
  - (a) By rezoning Lot 3 and Lot 7, Section 67, Comox District, Plan VIP55151, as shown in bold outline on **Attachment A** which is attached hereto and forms part of this bylaw, from Commercial Two (C-2) to Residential Four A (R-4A);
  - (b) By amending Section 8.4.11 to add “(7) *Care facility*”;
  - (c) By amending Section 8.4.11 to add “(8) Accessory commercial services for the personal care and convenience of onsite residents;
  - (d) By amending Section 8.4.11 to add “(9) *Community Service* limited to adult daycare”;
  - (e) By amending Section 8.4.14 to add “(3) *Care facility* – 1.0 floor area ratio”;
  - (f) That Schedule No. 8 be amended accordingly.
3. This bylaw shall come into effect upon final adoption hereof.

Read a first time this 15<sup>th</sup> day of May, 2017

Read a second time this 15<sup>th</sup> day of May, 2017

Considered at a Public Hearing this 8<sup>th</sup> day of August, 2017

Read a third time this 21<sup>st</sup> day of August, 2017

Finally passed and adopted this                      day of                      , 2018

\_\_\_\_\_  
Mayor

\_\_\_\_\_  
Director of Legislative Services

Approved under S.52(3)(a) of the *Transportation Act*

\_\_\_\_\_

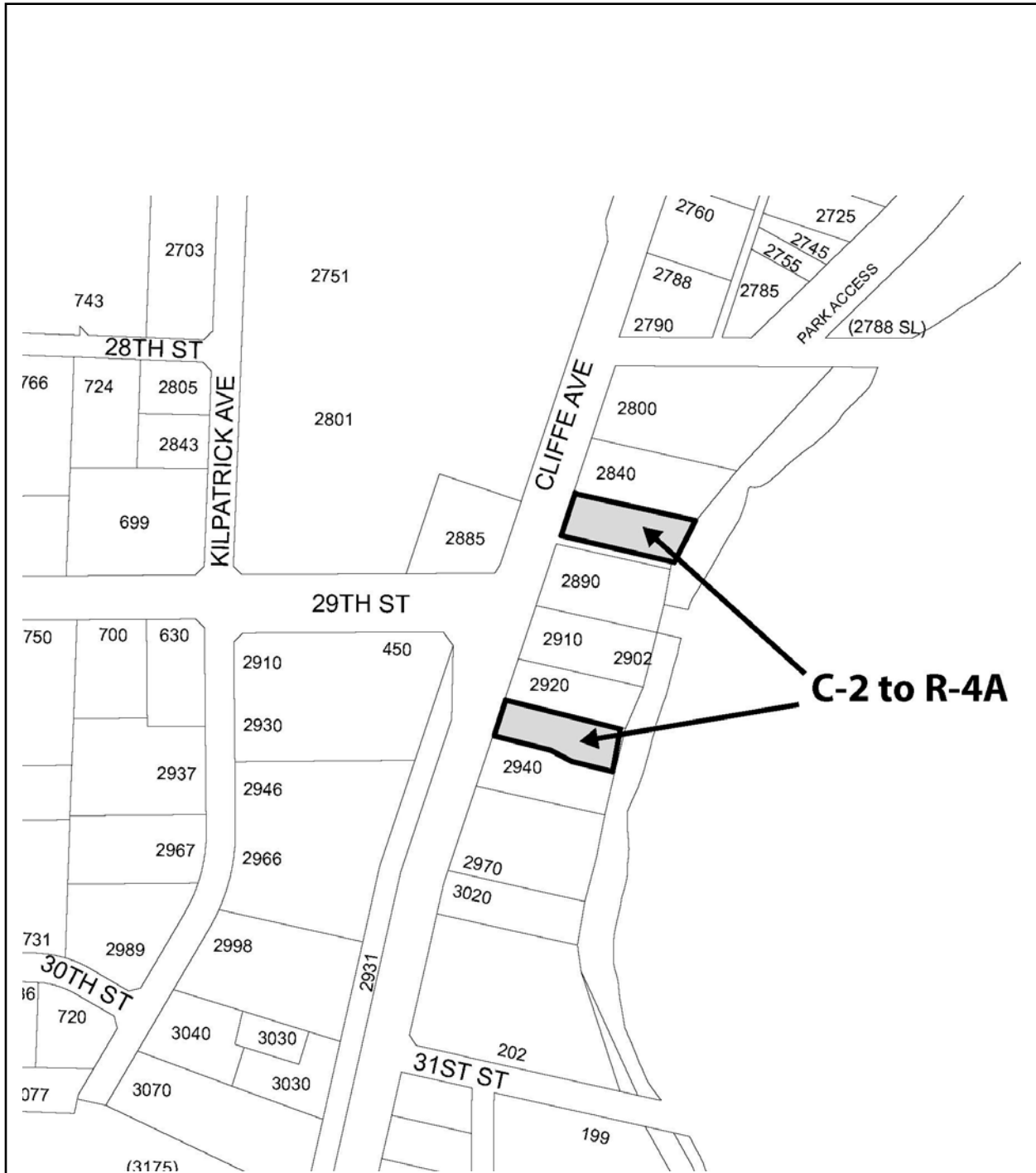

**C-2 to R-4A**

**THE CITY OF COURTENAY**  
**ATTACHMENT "A"**  
 Part of Bylaw No. 2870, 2017  
 Amendment to the  
 Zoning Bylaw No. 2500, 2007



## THE CORPORATION OF THE CITY OF COURTENAY

### ROAD CLOSURE BYLAW NO. 2876, 2017

WHEREAS, pursuant to Section 40 of the *Community Charter*, Council may, by bylaw, close a portion of a highway to traffic and remove the dedication of the highway, if prior to adopting the bylaw, Council publishes notices of its intention in a newspaper and provides an opportunity for persons who consider they are affected by the bylaw to make representations to Council;

AND WHEREAS the Council of the City of Courtenay deems it expedient to close to traffic and remove the dedication of highway of that portion of highway comprising of four hundred seventy seven (477) square metres in area in Part of Section 67, Comox District, Dedicated as Road on Plan VIP77721 which is shown outlined in bold black on the reference plan prepared by Michael J. Hansen, B.C.L.S. 815 on the 16<sup>th</sup> day of March 2017, a reduced copy of which is attached hereto as Schedule “A”;

AND WHEREAS notices of Council’s intention to close this portion of highway to traffic, to remove its dedication as highway, and to dispose of it were published in a newspaper and posted in the public notice posting place, and Council has provided an opportunity for persons who consider they are affected by the closure and disposition to make representations to Council;

AND WHEREAS the Council does not consider that the closure of that portion of highway will affect the transmission or distribution facilities or works of utility operators;

NOW THEREFORE the Council of the City of Courtenay in open meeting assembled, enacts as follows:

1. That portion of highway comprising of four hundred seventy seven (477) square metres in area in Part of Section 67, Comox District, Dedicated as Road on Plan VIP77721 which is shown outlined in bold black on the reference plan prepared by Michael J. Hansen, B.C.L.S. 815 on the 16<sup>th</sup> day of March 2017, attached hereto as Schedule “A” (the Closed Road), is closed to all types of traffic, and its dedication as highway is removed.
2. On deposit of the reference plan attached hereto as Schedule “A” and all other documentation for the closure of the Closed Road in the Victoria Land Title Office, the Closed Road is closed to traffic, it shall cease to be public highway, and its dedication as highway is cancelled.
3. The Mayor and Director of Legislative Services are authorized to execute and deliver such transfers, deeds of land, plans and other documentation as may be necessary for the purposes aforesaid.
4. This Bylaw may be cited as “**Road Closure Bylaw No. 2876, 2017**”.

Read a first time this 15<sup>th</sup> day of May, 2017

Read a second time this 15<sup>th</sup> day of May, 2017

Read a third time this 15<sup>th</sup> day of May, 2017

Published in two editions of the Comox Valley Record on the 25<sup>th</sup> day of May, 2017

Finally passed and adopted this     day of     , 2018

---

Mayor

---

Director of Legislative Services

Approved under S.41(3) of the *Community Charter*

---